

Quality assurance of absorbed energy in Charpy impact test

This content has been downloaded from IOPscience. Please scroll down to see the full text.

2016 J. Phys.: Conf. Ser. 733 012009

(<http://iopscience.iop.org/1742-6596/733/1/012009>)

View [the table of contents for this issue](#), or go to the [journal homepage](#) for more

Download details:

IP Address: 177.221.163.9

This content was downloaded on 02/08/2016 at 02:29

Please note that [terms and conditions apply](#).

Quality assurance of absorbed energy in Charpy impact test

C L F Rocha¹, D A K Fabricio¹, V M Costa¹ and A Reguly¹

¹ Physical Metallurgy Laboratory (LAMEF) / Federal University of Rio Grande do Sul, 99 Osvaldo Aranha Avenue, Porto Alegre, Rio Grande do Sul, Brazil.

E-mail: cfanezi@demet.ufrgs.br

Abstract. In order to ensure the quality assurance and comply with standard requirements, an intralaboratory study has been performed for impact Charpy tests, involving two operators. The results based on ANOVA (Analysis of Variance) and Normalized Error statistical techniques pointed out that the execution of the tests is appropriate, because the implementation of quality assurance methods showed acceptable results.

1. Introduction

According to ASTM E23, Charpy impact test determines the amount of energy absorbed by a standard sample during fracture [1]. ISO/IEC 17025 standard establishes the general requirements for technical competence in test and calibration laboratories. One of the requirements is the quality assurance of results based on pre-established acceptance criteria [2-3].

A statistical methodology for the evaluation of the significance of different factors and their interactions is the Analysis of Variance (ANOVA). This technique allows the comparison of variances between average values of a variable at different levels of a factor, resulting in a statistical value called *p*-value. This value represents the probability of significance of the analyzed factor. When *p*-value < *P* (significance level), the analyzed factor is considered significant in relation to the residual error.

In monitoring the quality of test results, another statistical method often used is Normalized Error (E_n). This method tests the compatibility of measured values with a reference value. The value of E_n can be calculated according to equation (1) [5]. The result is considered acceptable when $E_n \leq 1$.

$$E_n = |X_1 - X_2| [(u_1^2 + u_2^2)^{1/2}]^{-1} \quad (1)$$

Equation (1) represents a ratio between the difference of the average values of two analyzed parameters ($X_1 - X_2$) and the square roots of the square sum of the expanded measurement uncertainty of both parameters (u_1 and u_2).

Thus, this paper intends to carry out a comparative study of the absorbed energy in impact testing, through the statistical methods of Normalized Error and ANOVA.



2. Material and Methods

Impact tests have been carried out with standardized test specimens, according to figure 1, type 'A' notch was prepared, following standard orientations for dimensional tolerance.

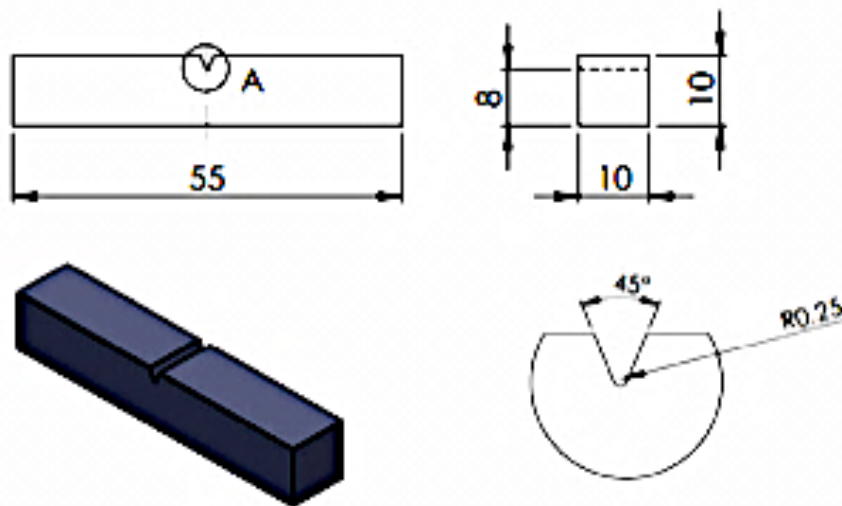

Figure 1. Test specimens, dimensions in millimeters.

For statistical analysis, two operators (A and B) have tested three test specimens each (i.e. 6 specimens under the same conditions). After measuring the samples, data has been analyzed through ANOVA and Normalized Error methods, considering operator as analyzed factor.

The acceptance criteria for normalized error has been $E_n \leq 1$ and for ANOVA has been $p\text{-value} < P$, as indicated in literature.

Impact tests have been carried out using an Instron analogic impact test machine, with 400 J of capacity and 2 J of resolution.

3. Results and Discussion

Results of absorbed energy (KV_δ) in Charpy testing and the uncertainty associated to KV_δ ($u(KV_\delta)$) are shown in table 1. The estimation of the uncertainty was according to ISO/GUM [6], considering the resolution, standard deviation and calibration for KV_δ .

Table 1. Charpy impact test results.

Specimen	KV_8	Mean KV_8	$u(KV_8)$	Operator
A.1	154 J	156.67 J	17.04 J	A
A.2	152 J			
A.3	164 J			
B.1	138 J	150.00 J	29.24 J	B
B.2	152 J			
B.3	160 J			

According to table 1, $E_n = |(156.67) - (150.00)|/[(17.04)^2+(29.24)^2]^{(1/2)} = 0.197$. Results are considered satisfactory, because $E_n \leq 1$.

ANOVA has been estimated using a significance level of 5%. Results are presented in table 2, where SQ represents the sum of squares, DF represents the degrees of freedom and MS the mean of squares.

Table 2. ANOVA for operators.

Source	SQ	DF	MS	p -value
Operator	66.67	1	66.67	0.42
Error	330.67	4	82.67	
Total	397.33	5		

According to the results in table 2, it was not possible to prove the effect of the operator at a significance value (P) of 5%, since p -value = 0.42 > $P = 0.05$. This result is satisfactory, since an effect of the operator in the result is undesired.

Thus, by both techniques (ANOVA and E_n), it is possible to conclude the operator effect does not affect the result. That is, Charpy impact test is considered compatible for this application.

4. Conclusion

The statistical analysis proposed in this paper, comply with the ISO/IEC 17025 quality assurance requirement for the Charpy impact test with in an easy and reliable method. Although the participation in interlaboratory tests is necessary.

The statistical test Normalized Error between operators has been resulted satisfactory, considering the value of E_n was smaller than 1.

The technique based on ANOVA has resulted in a conclusion equivalent to the normalized error, since p -value was larger than the specified significance level $P = 5\%$.

It is possible to conclude that these two statistical methods can be used for quality control of Charpy impact tests. The execution of the tests is appropriate, because the implementation of quality assurance methods showed acceptable results.

5. References

- [1] Garcia A, Spim J and Santos C A 2012 Ensaio dos Materiais. Rio de Janeiro, LTC, vol. 2
- [2] ASTM International 2007 ASTM E23: Standard Test Methods for Notched Bar Impact Testing of Metallic Materials. Pennsylvania
- [3] Associação Brasileira de Normas Técnicas 2005 NBR ISO/IEC 17025: Requisitos gerais para a competência de laboratórios de ensaio e calibração. Rio de Janeiro
- [4] Ribeiro J L D and Caten C S T 2012 Cartas de Controle para Variáveis, Cartas de Controle para Atributos, Função de Perda Quadrática, Análise de Sistemas de Medição. FEENG/UFRGS, Porto Alegre
- [5] INMETRO 2010 DOQ-CGCRE-008: Orientação sobre Validação de Métodos Analíticos. Coordenação Geral de Acreditação, 3rd revision
- [6] JCGM 2008 Evaluation of measurement data: Guide to the expression of uncertainty in measurement. Geneva