



INSTITUTO CURIE:  
Resignificar a Inovação

Marla Thomas  
Orientador César Vieira

Localizado no 16 arrondissement de Paris na França



Ressignificar um dos berços da pesquisa científica mundial:  
o laboratório da descoberta da radioatividade. 🏛️

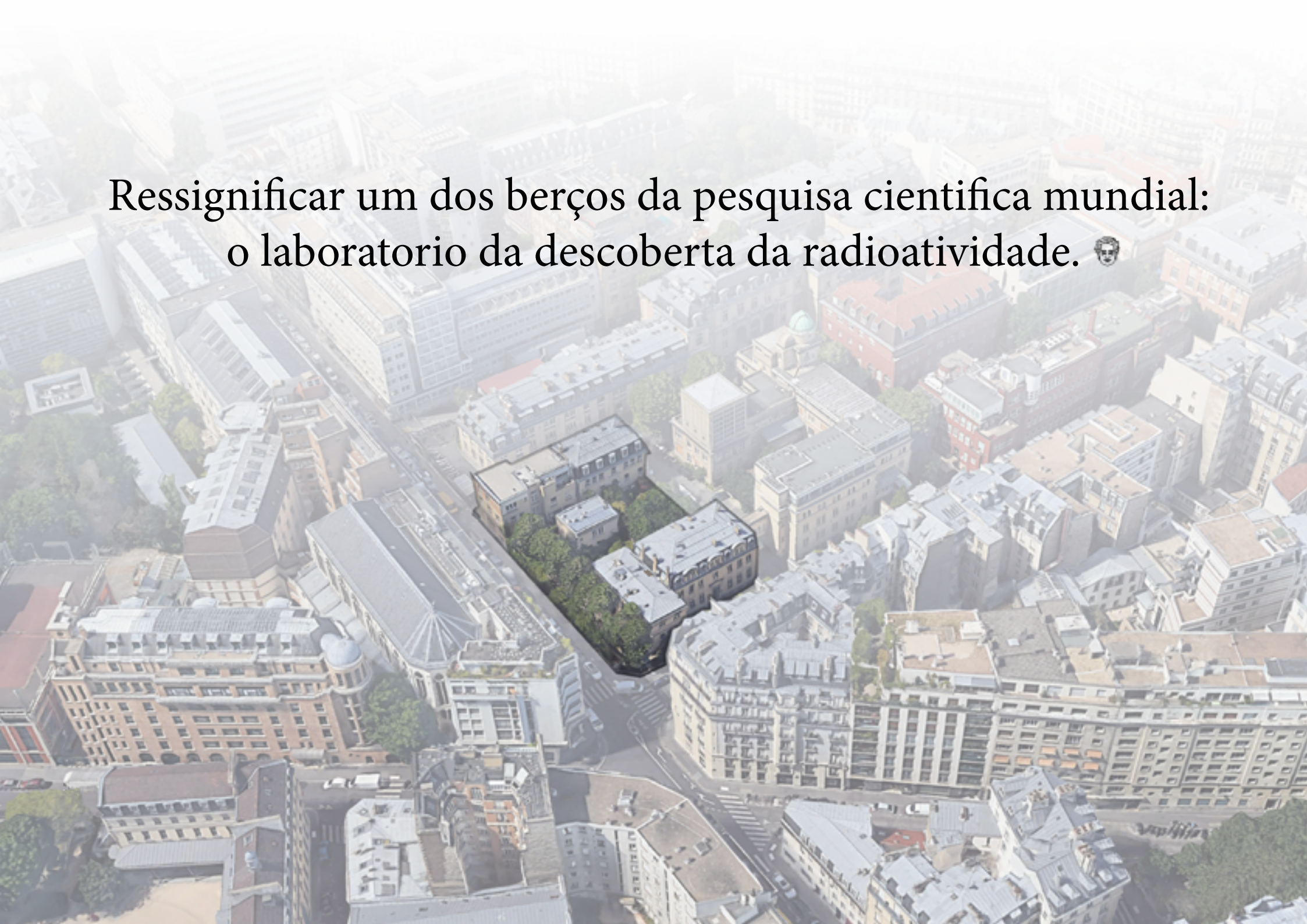

- Propondo uma nova identidade arquitetônica para o local;

- Propondo uma nova identidade arquitetônica para o local;
- Aliando as novas tecnologia da construção com o patrimonio histórico;

- Propondo uma nova identidade arquitetônica para o local;
- Aliando as novas tecnologia da construção com o patrimonio histórico;
- Enfatizando a importância de criar simbolos femininos nas cidades contemporâneas.

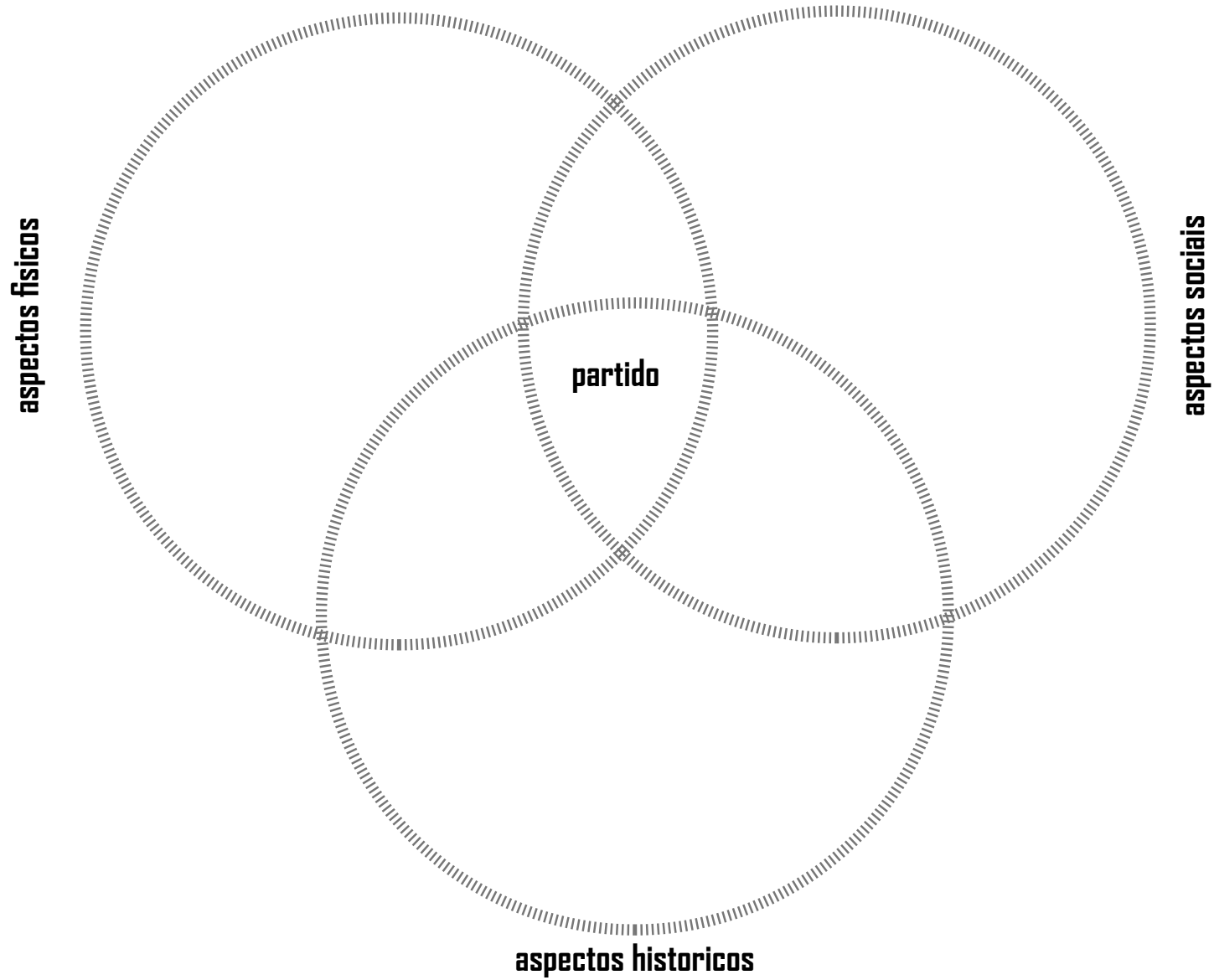

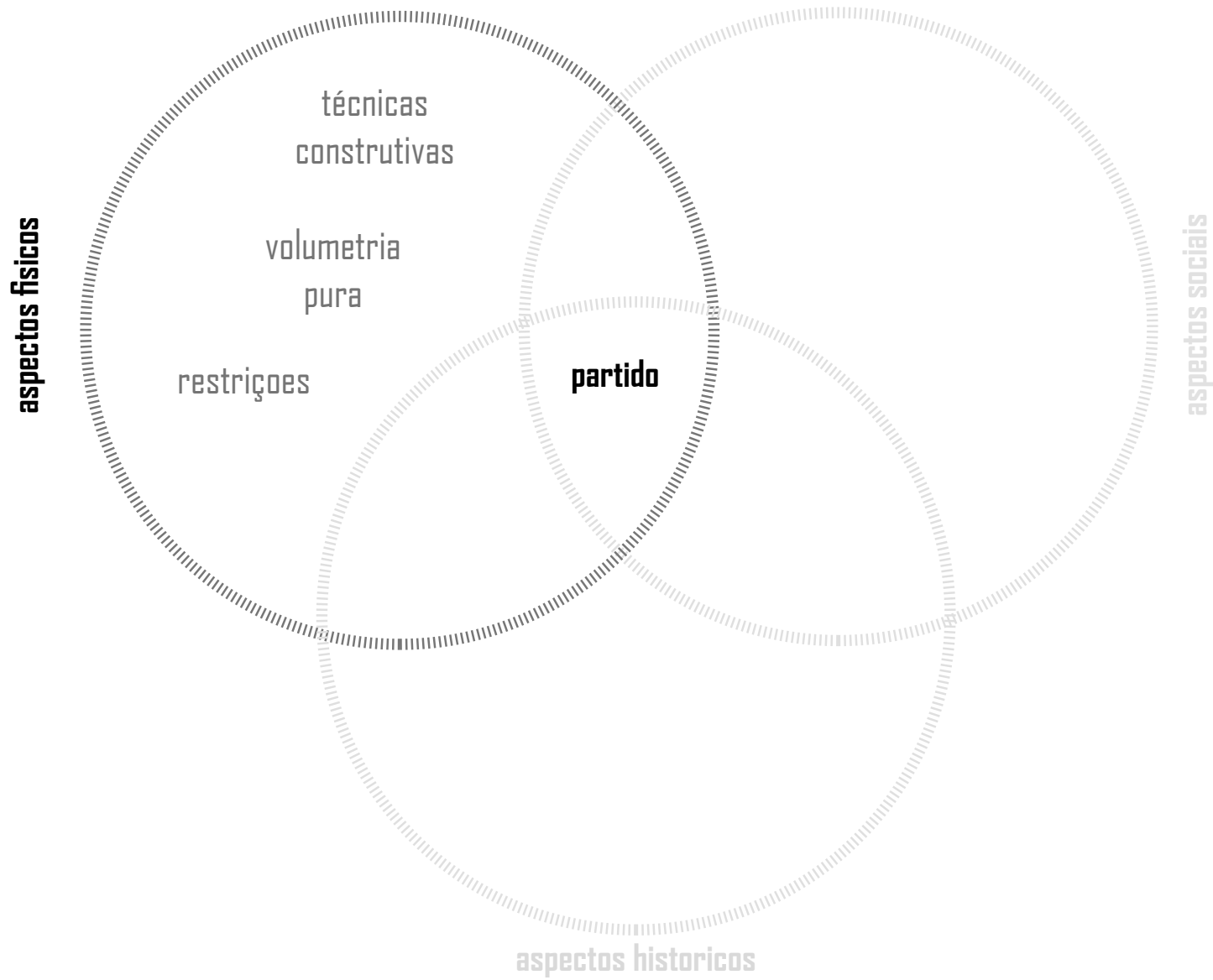



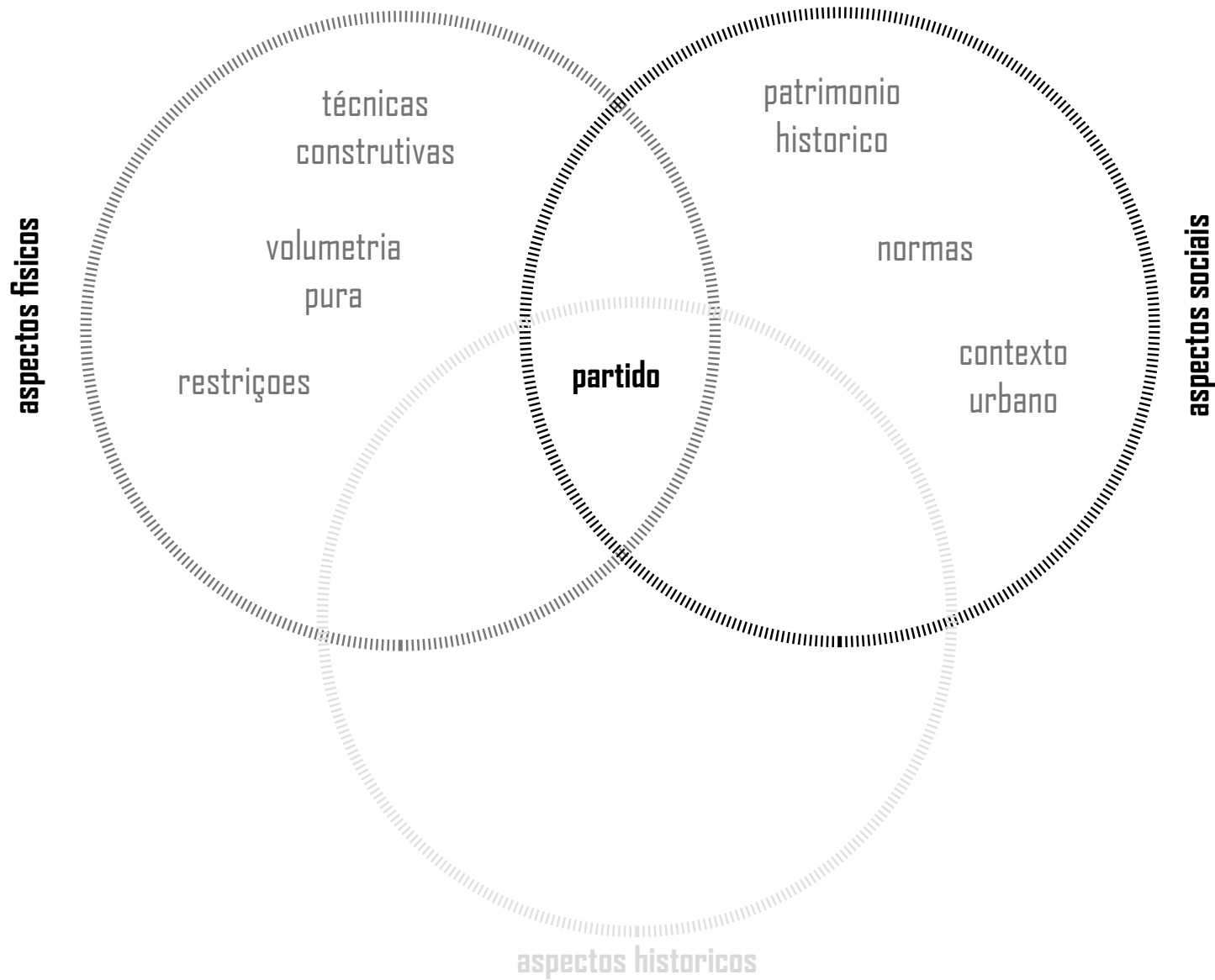

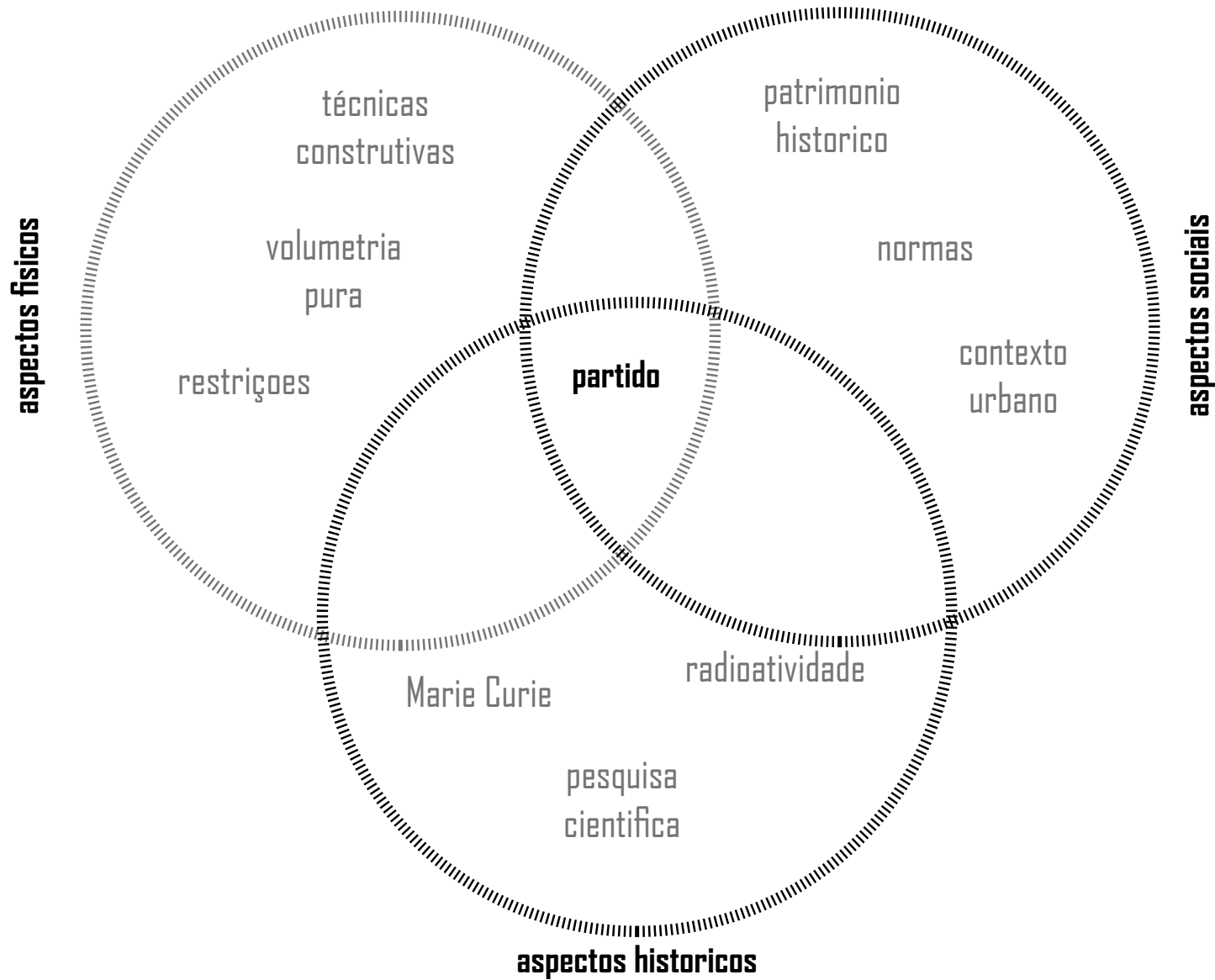

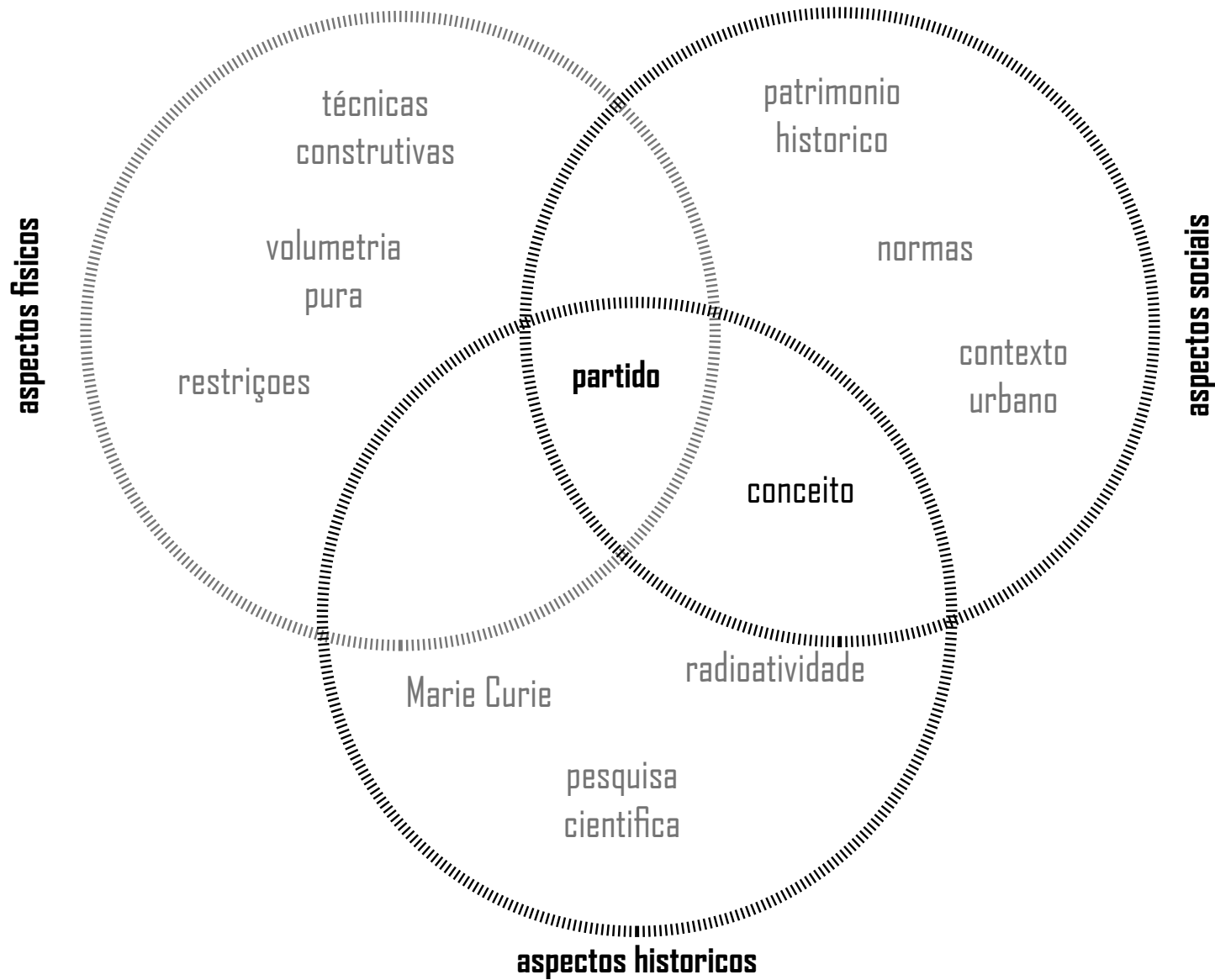

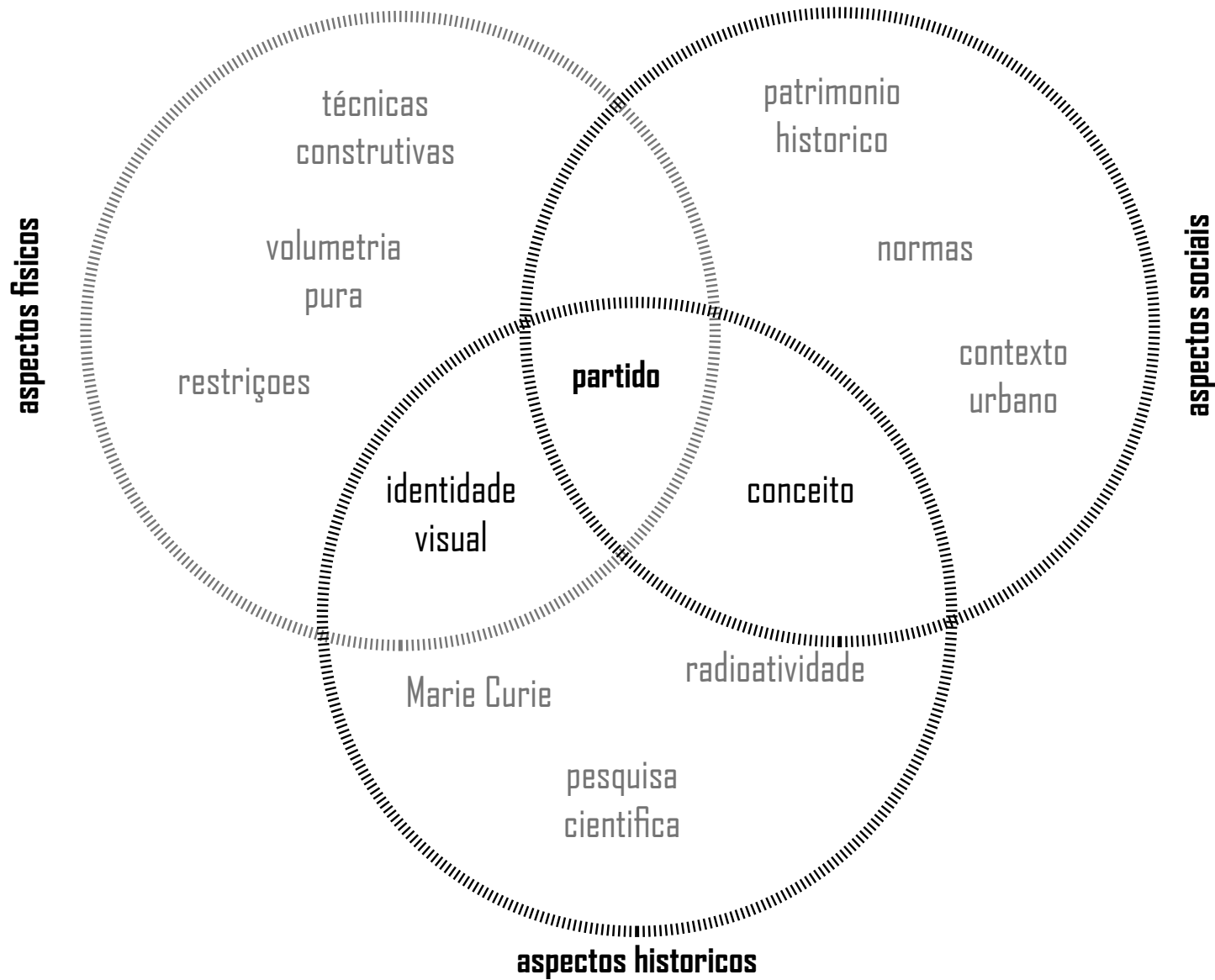

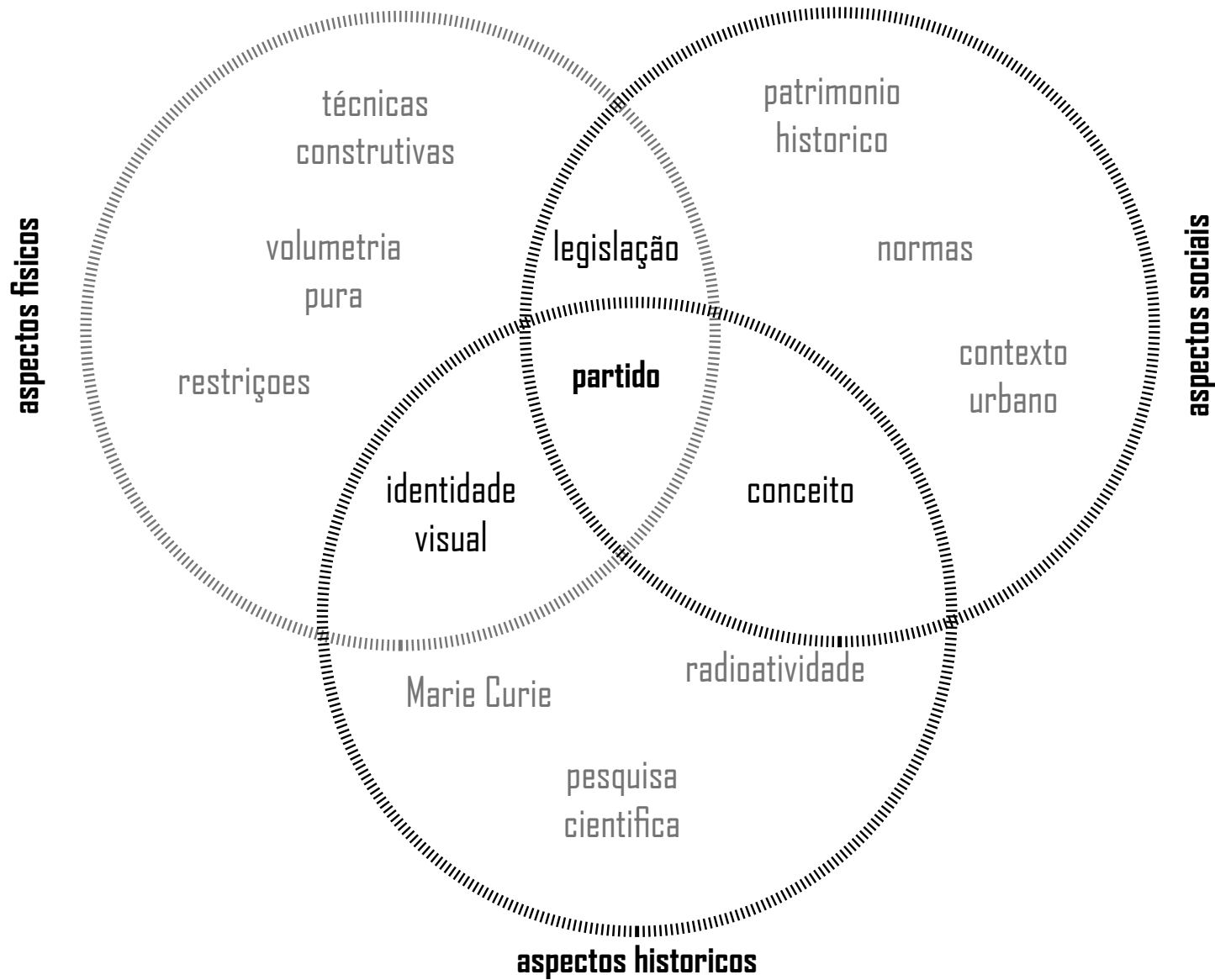



1867

---

nascimento de  
Manya  
Sklodowska

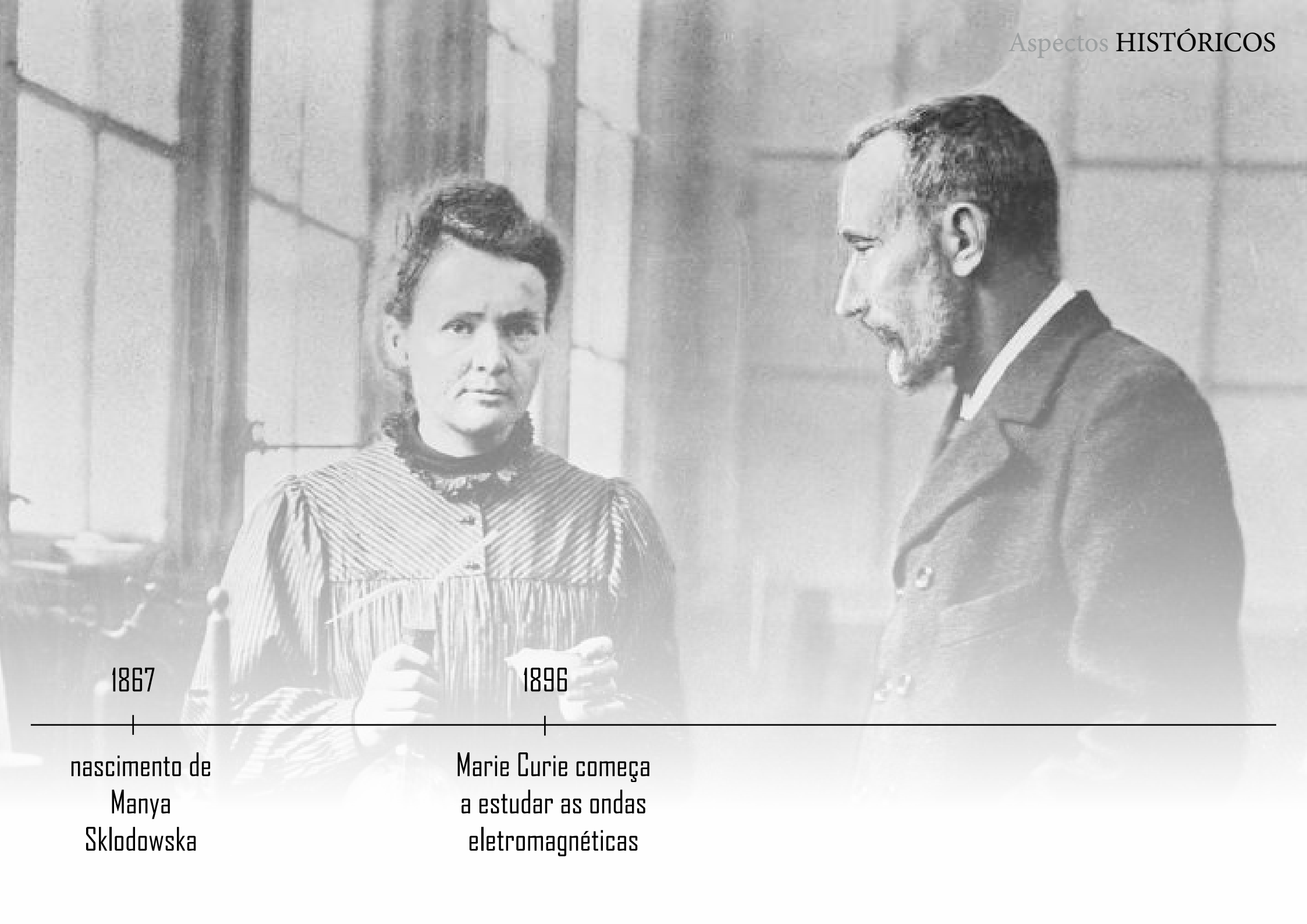

1867

nascimento de  
Manya  
Sklodowska

1896

Marie Curie começa  
a estudar as ondas  
eletromagnéticas

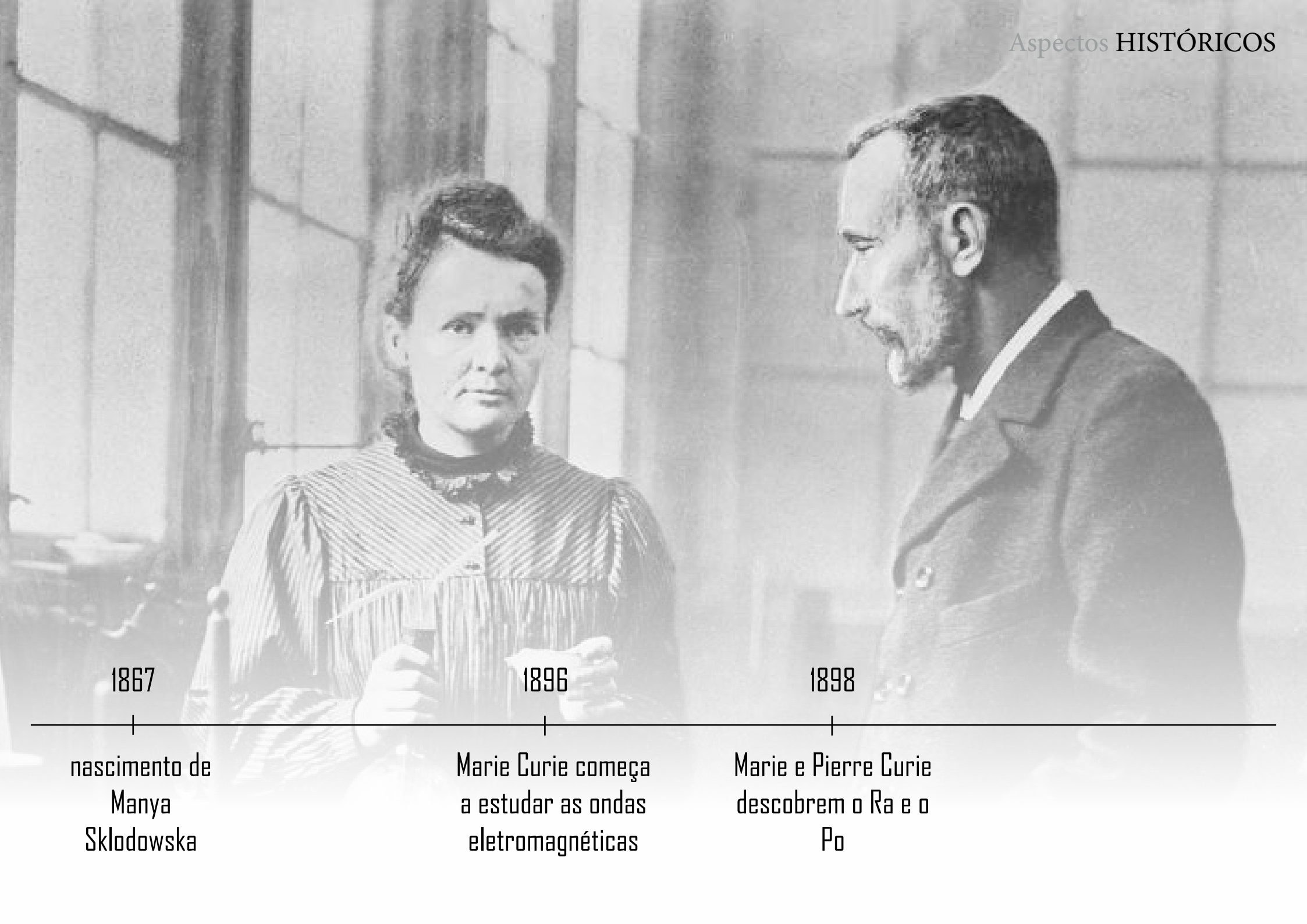

1867

nascimento de  
Manya  
Sklodowska

1896

Marie Curie começa  
a estudar as ondas  
eletromagnéticas

1898

Marie e Pierre Curie  
descobrem o Ra e o  
Po



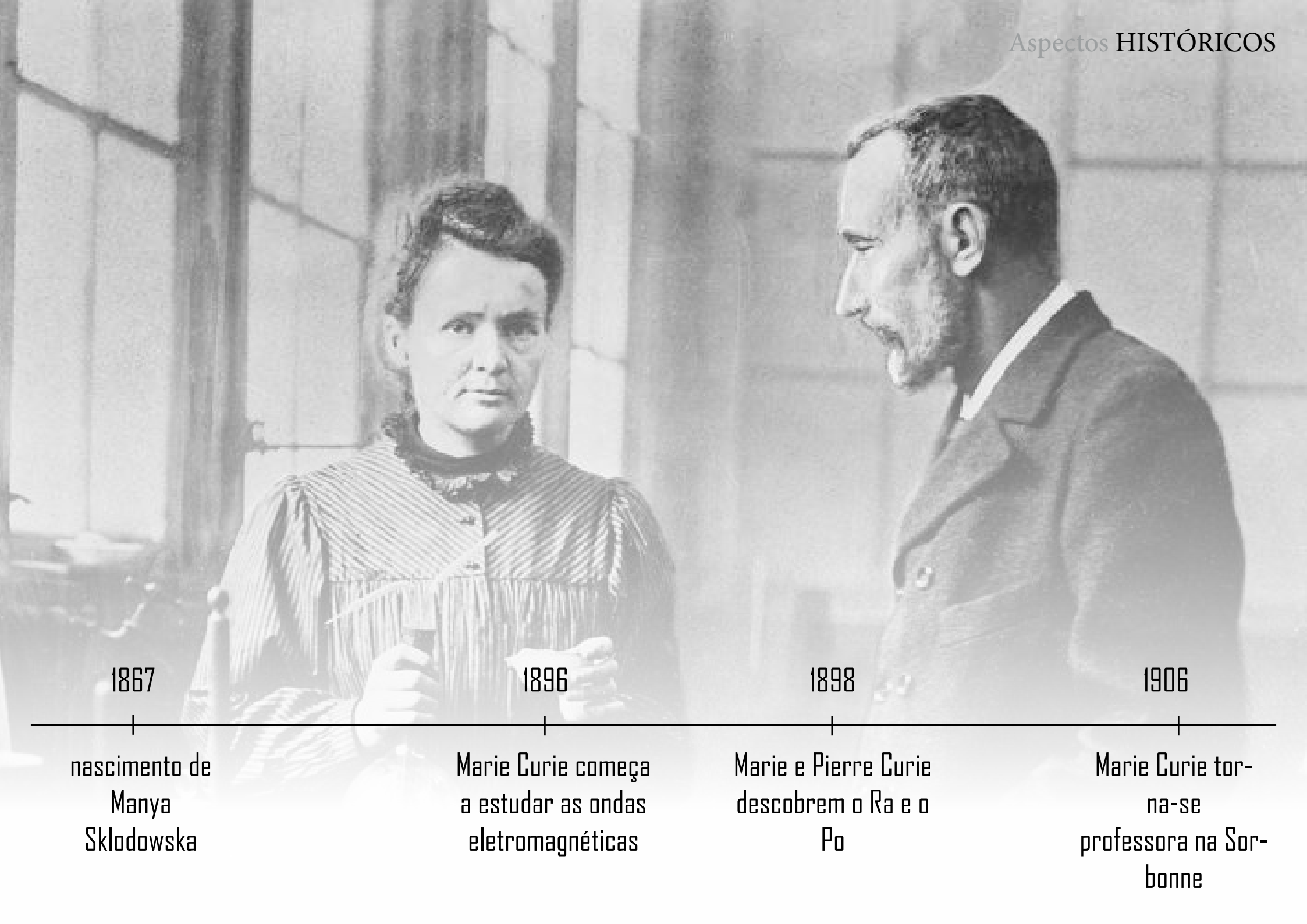

1867

nascimento de  
Manya  
Sklodowska

1896

Marie Curie começa  
a estudar as ondas  
eletromagnéticas

1898

Marie e Pierre Curie  
descobrem o Ra e o  
Po

1906

Marie Curie tor-  
na-se  
professora na Sor-  
bonne



1910

---

Marie Curie ganha o  
2º Prêmio Nobel de  
Ciência



1910

1914

Marie Curie ganha o  
2º Prêmio Nobel de  
Ciência

Inauguração do  
Institut du Radium



1910

1914

1921

Marie Curie ganha o  
2º Prêmio Nobel de  
Ciência

Inauguração do  
Institut du Radium

Marie Curie cria o  
Institut Curie



1910

1914

1921

1934

Marie Curie ganha o  
2º Prêmio Nobel de  
Ciência

Inauguração do  
Institut du Radium

Marie Curie cria o  
Institut Curie

Marie Curie morre  
de leucemia



Laboratorio Marie Curie

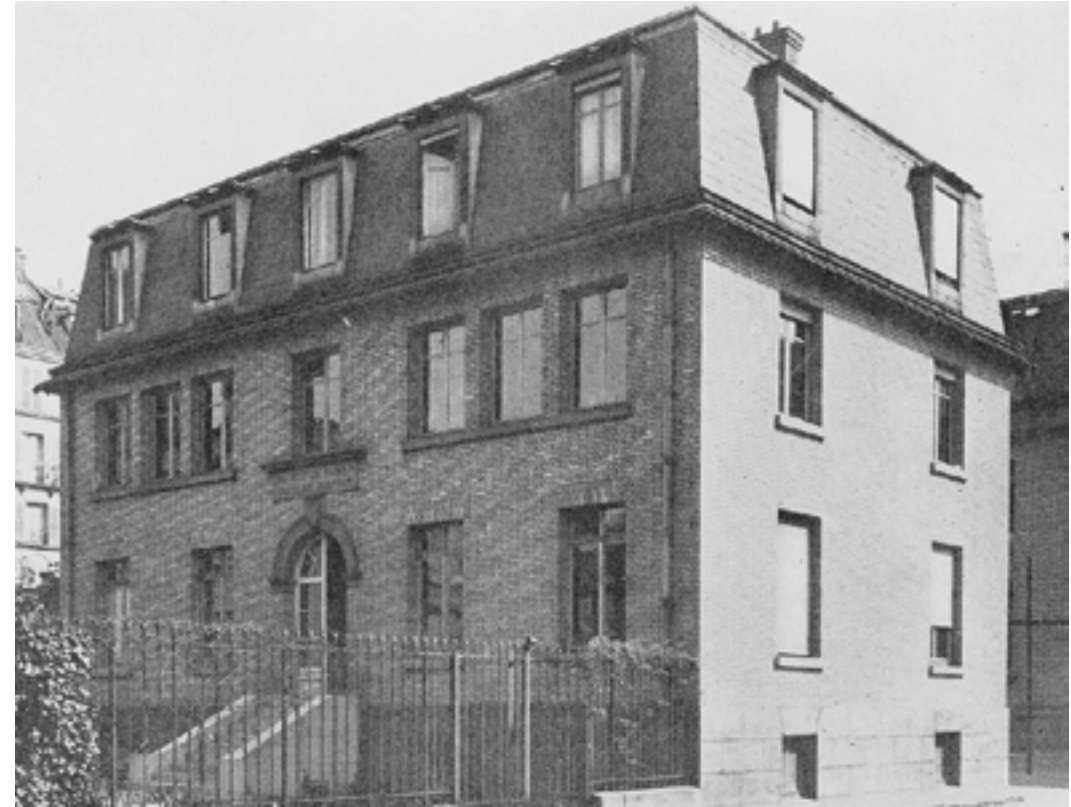

Institut du Radium



RAIO X= ONDAS  
ELETROGANÉTICAS



TESE DOUTORADO  
MARIE CURIE



RAIO X= ONDAS  
ELETROGANÉTICAS



TESE DOUTORADO  
MARIE CURIE



DESCOBERTA  
DO RADIUM E DO  
POLONIUM



DESCOBERTA DAS  
BASES DA  
RADIATIVIDADE





RAIO X= ONDAS  
ELETROGANÉTICAS



TESE DOUTORADO  
MARIE CURIE



DESCOBERTA  
DO RADIUM E DO  
POLONIUM



DESCOBERTA DAS  
BASES DA  
RADIATIVIDADE



DESCOBRIR: tirar aquilo  
que esconde ou  
cobre algo



A PARTIR DA DESCOBERTA  
DOS RAIOS X,  
A RADIOATIVIDADE FOI  
DESCOBERTA



---

NOVO CENTRO DE INOVAÇÃO MARIE CURIE

---



---

NOVO CENTRO DE INOVAÇÃO MARIE CURIE



CENTRO DE STARTUPS  
LIGADAS A PESQUISA  
LABORATORIAL



NOVO CENTRO DE INOVAÇÃO MARIE CURIE

CENTRO DE EVENTOS DO  
INSTITUTO CURIE

CENTRO DE STARTUPS  
LIGADAS A PESQUISA  
LABORATORIAL



NOVO CENTRO DE INOVACAO MARIE CURIE

CENTRO DE EVENTOS DO  
INSTITUTO CURIE

CENTRO DE STARTUPS  
LIGADAS A PESQUISA  
LABORATORIAL

NUCLEO DE PESQUISA  
LABORATORIAL  
PERENE

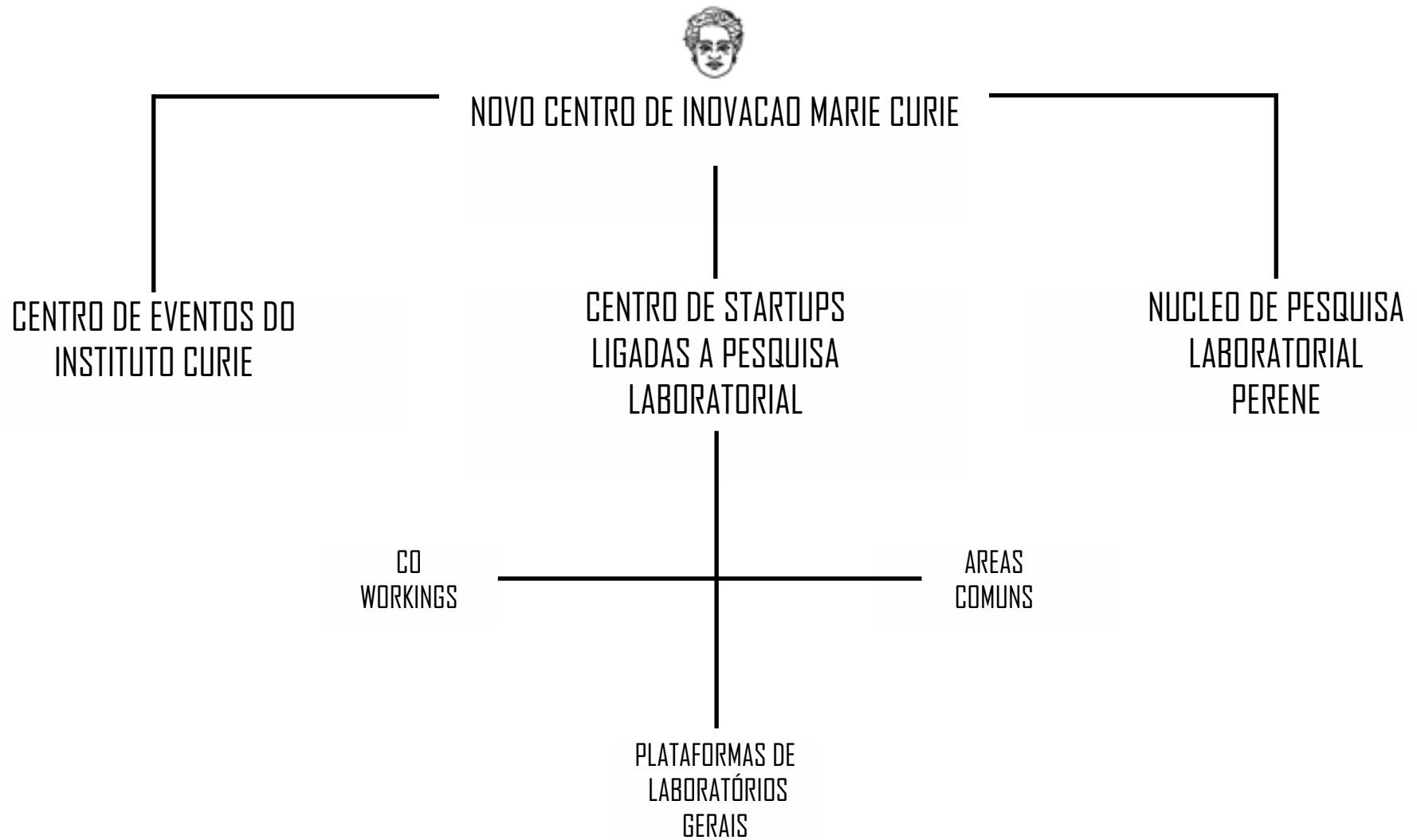



NOVO CENTRO DE INOVAÇÃO MARIE CURIE

CENTRO DE EVENTOS DO  
INSTITUTO CURIE

CENTRO DE STARTUPS  
LIGADAS A PESQUISA  
LABORATORIAL

NUCLEO DE PESQUISA  
LABORATORIAL  
PERENE

CO  
WORKINGS

AREAS  
COMUNS

SALAS DE CONFERÊN-  
CIAS

HALL DE  
ENTRADA DO INSTI-  
TUTO

PLATAFORMAS DE  
LABORATÓRIOS  
GERAIS



NOVO CENTRO DE INOVAÇÃO MARIE CURIE

CENTRO DE EVENTOS DO  
INSTITUTO CURIE

CENTRO DE STARTUPS  
LIGADAS A PESQUISA  
LABORATORIAL

NUCLEO DE PESQUISA  
LABORATORIAL  
PERENE

CO  
WORKINGS

AREAS  
COMUNS

SALAS DE CONFERÊN-  
CIAS

HALL DE  
ENTRADA DO INSTI-  
TUTO

PLATAFORMAS DE  
LABORATÓRIOS  
GERAIS

LABORATORIOS  
ESPECÍFICOS

ESCRITÓRIOS



# PLANO URBANÍSTICO - LINHAS GERAIS

# Aspectos FÍSICOS

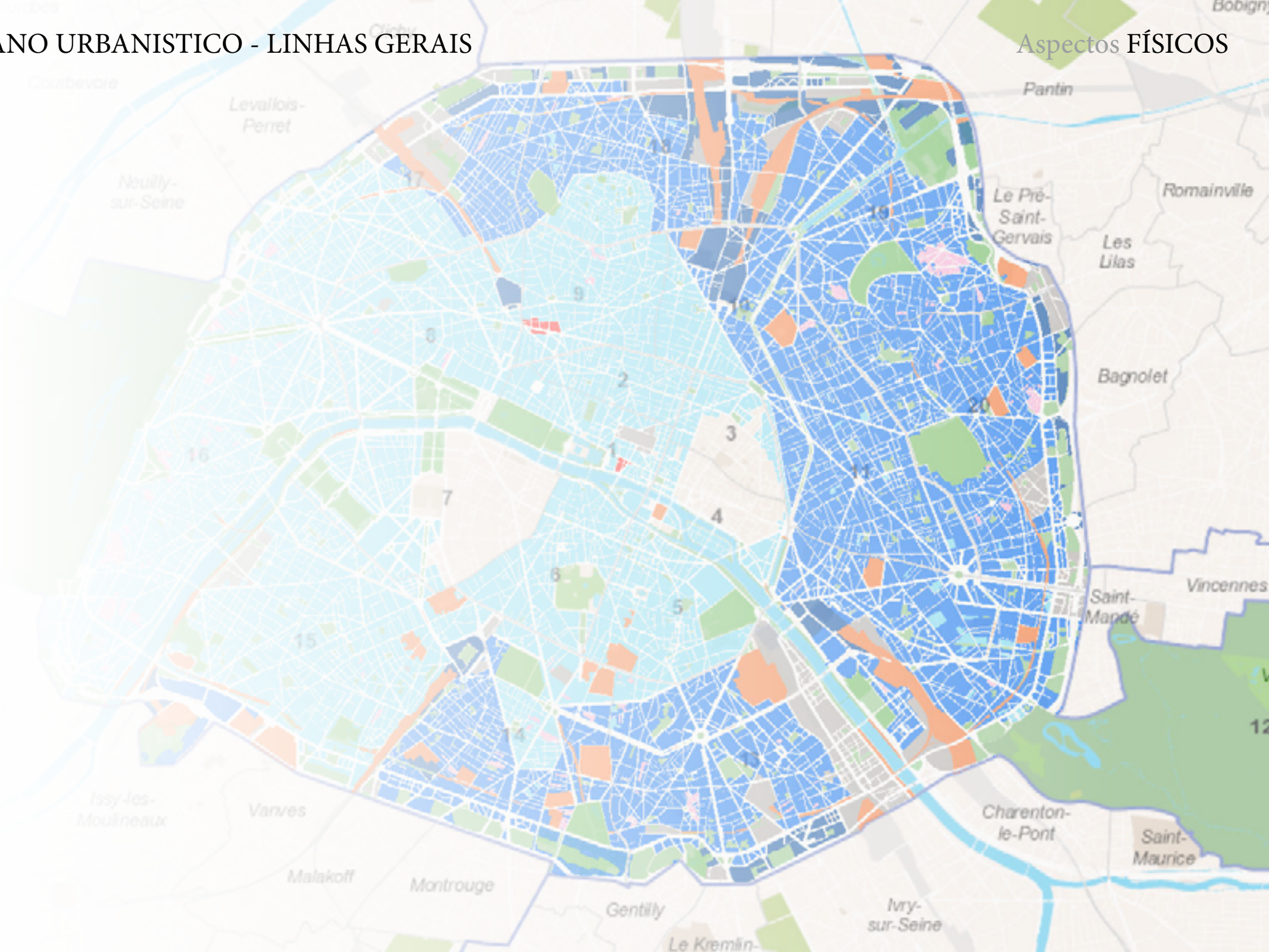

# PLANO URBANÍSTICO - LINHAS GERAIS

# Aspectos FÍSICOS



## Zonages et destinations

-  Zone UG - Secteur plus favorable à l'emploi
-  Zone UG - Site de protection des Grands magasins
-  Zone UG - Secteur privilégiant l'habitation
-  Zone UG - Secteur favorisant mixité habitat-emploi
-  Zone UG - ZAC ou Secteur d'aménagement
-  Zone UG - Secteur de Maison et Villas

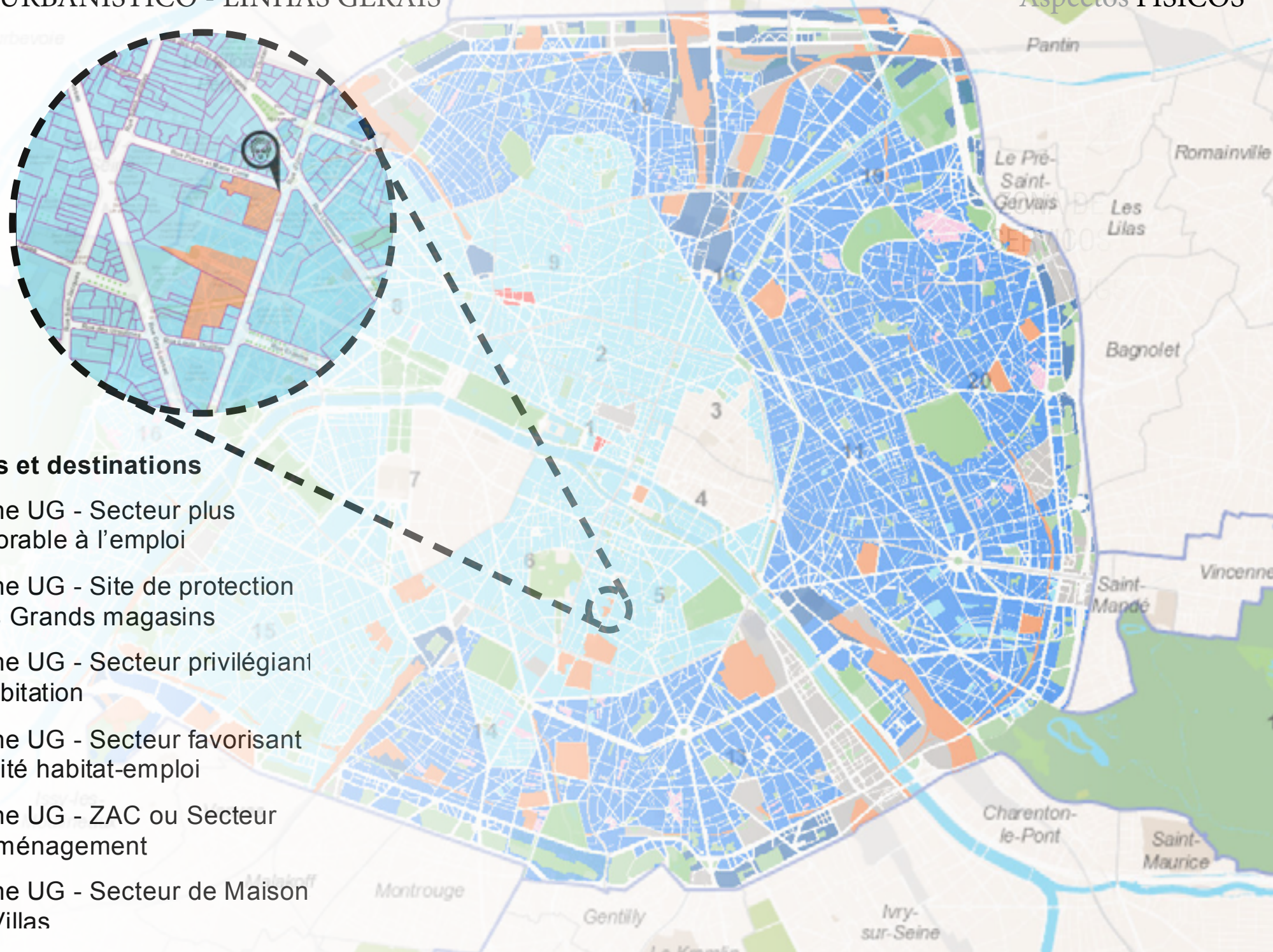



# PLANO URBANÍSTICO - LINHAS GERAIS

# Aspectos FÍSICOS



ESPAÇO VEGETAL  
PROTÉGIDO  
E ZONAS VERDES  
À EVIDENCIAR

## Sectorisation végétale de la Zone Urbaine Générale

-  Renforcement du végétal
-  Mise en valeur du végétal





# PLANO URBANISTICO - LINHAS GERAIS

# Aspectos FÍSICOS



ZONA DE PROTEÇÃO  
DO SUBSOLO

## Zones de gypses

-  Zone comportant des poches de gypse antéludien (PPRn)
-  Zone supplémentaire comportant des poches de gypse antéludien (hors PPRn)
-  Carrières (PPRn)

Map labels: Courbevoie, Pantin, Romainville, Le Pré-Saint-Gervais, Lilas, Bagnolet, Vincennes, Saint-Mandé, Charenton-le-Pont, Saint-Maurice, Malakoff, Montrouge, Gentilly, Le Kremlin-Bicêtre, Ivry-sur-Seine.





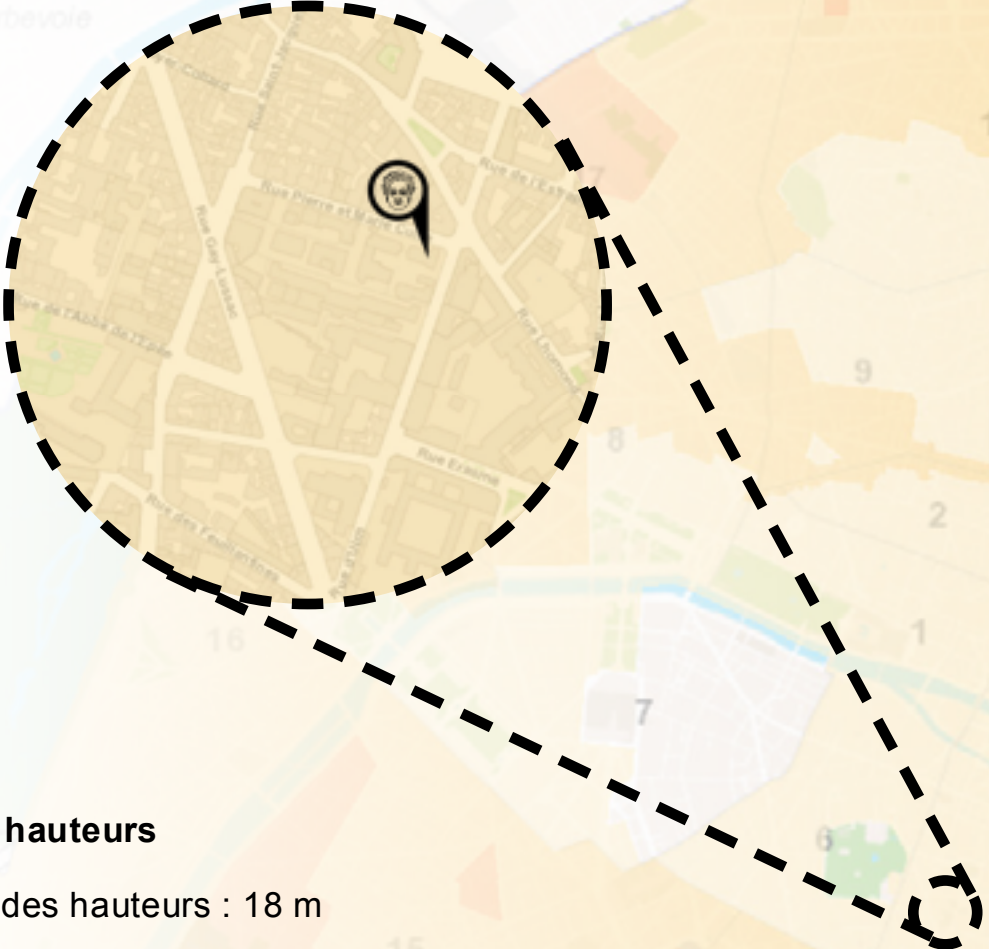

# PLANO URBANÍSTICO - LINHAS GERAIS

# Aspectos FÍSICOS



ZONA DE ALTURA MÁXIMA  
H=25m

### Plan des hauteurs

-  Plan des hauteurs : 18 m
-  Plan des hauteurs : 25 m
-  Plan des hauteurs : 31 m
-  Plan des hauteurs : 37 m
-  Plan des hauteurs : 50 m
-  Plan des hauteurs : 180 m

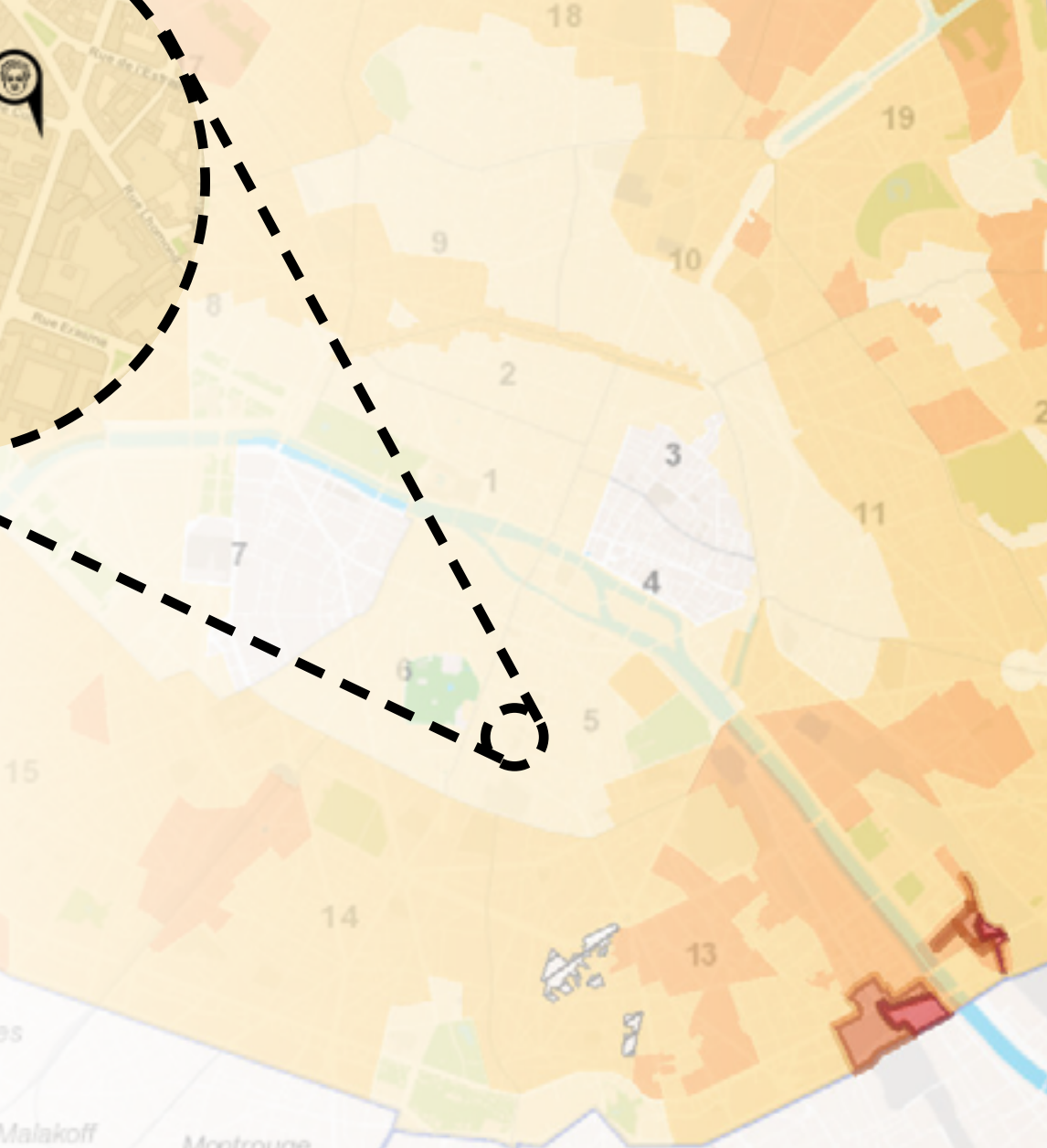



O ALINHAMENTO DEVE  
SER MARCADO POR  
ALGUM ELEMENTO  
ARQUITETÔNICO



O ALINHAMENTO DEVE  
SER MARCADO POR  
ALGUM ELEMENTO  
ARQUITETÔNICO



NOVAS CONTRUÇÕES  
DEVEM TER CARATER  
CONTEMPORÂNEO PARA  
QUE A ARQUITETURA  
ATUAL TENHA ESPAÇO NO  
CENÁRIO PARISIENSE.



O ALINHAMENTO DEVE SER MARCADO POR ALGUM ELEMENTO ARQUITETÔNICO



NOVAS CONTRUÇÕES DEVEM TER CARATER CONTEMPORÂNEO PARA QUE A ARQUITETURA ATUAL TENHA ESPAÇO NO CENÁRIO PARISIENSE.



NOVAS CONSTRUÇÕES DEVEM ESTAR EM HARMONIA COM O EXISTENTE, SEJA ESSA DADA PELAS CORES, ALTURAS DOS PRÉDIOS VIZINHOS, FORMA, RITMO DA FACHADA.





O ALINHAMENTO DEVE SER MARCADO POR ALGUM ELEMENTO ARQUITETÔNICO



NOVAS CONTRUÇÕES DEVEM TER CARATER CONTEMPORÂNEO PARA QUE A ARQUITETURA ATUAL TENHA ESPAÇO NO CENÁRIO PARISIENSE.



NOVAS CONSTRUÇÕES DEVEM ESTAR EM HARMONIA COM O EXISTENTE, SEJA ESSA DADA PELAS CORES, ALTURAS DOS PRÉDIOS VIZINHOS, FORMA, RITMO DA FACHADA.



TODAS AS INTERVENÇÕES DEVEM TER UM TÉRREO ABERTO AO NÍVEL DOS PEDESTRES E COM MATERIAIS DE ALTA QUALIDADE.

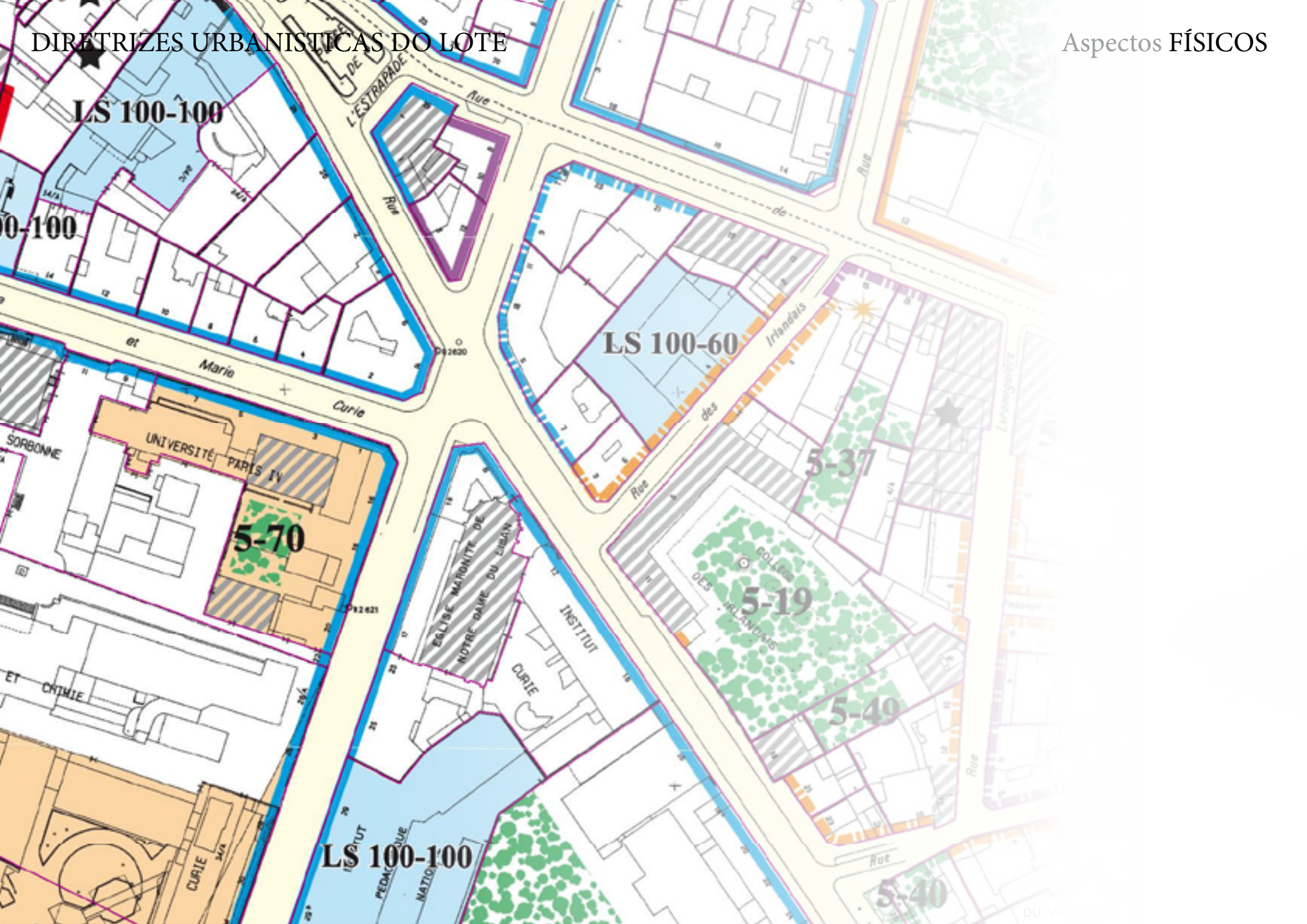

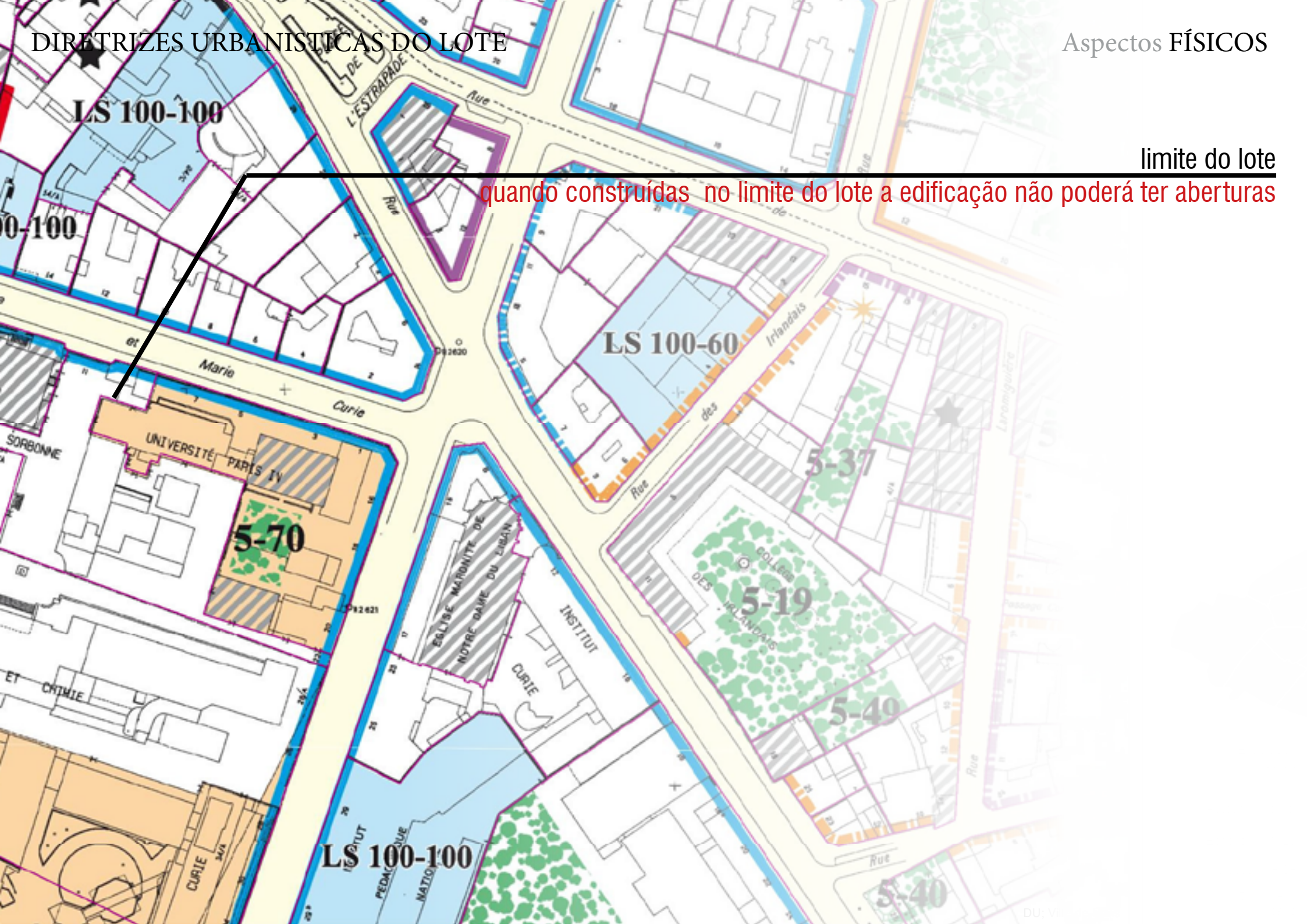

limite do lote  
quando construídas no limite do lote a edificação não poderá ter aberturas

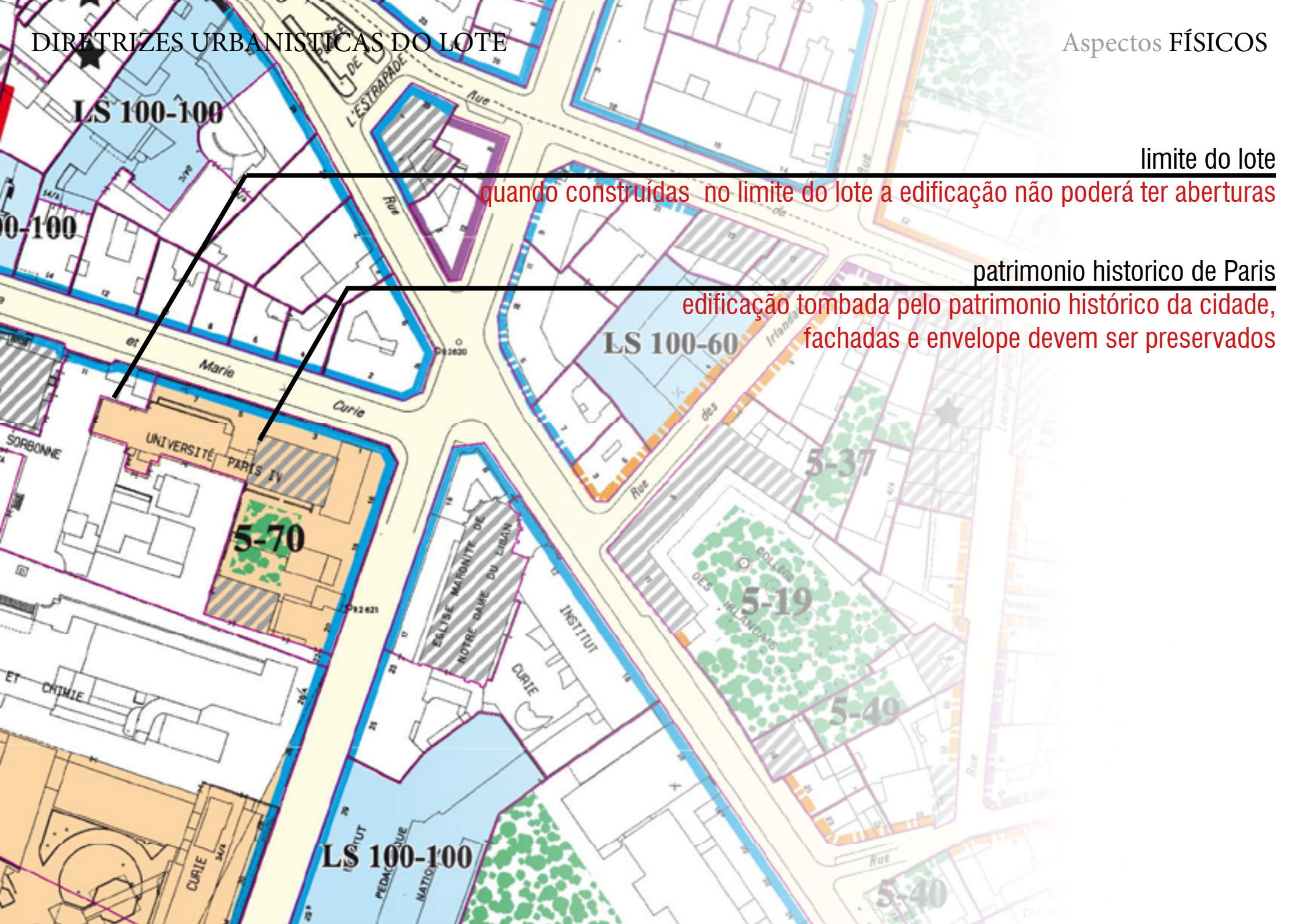

limite do lote

quando construídas no limite do lote a edificação não poderá ter aberturas

patrimônio histórico de Paris

edificação tombada pelo patrimônio histórico da cidade, fachadas e envelope devem ser preservados

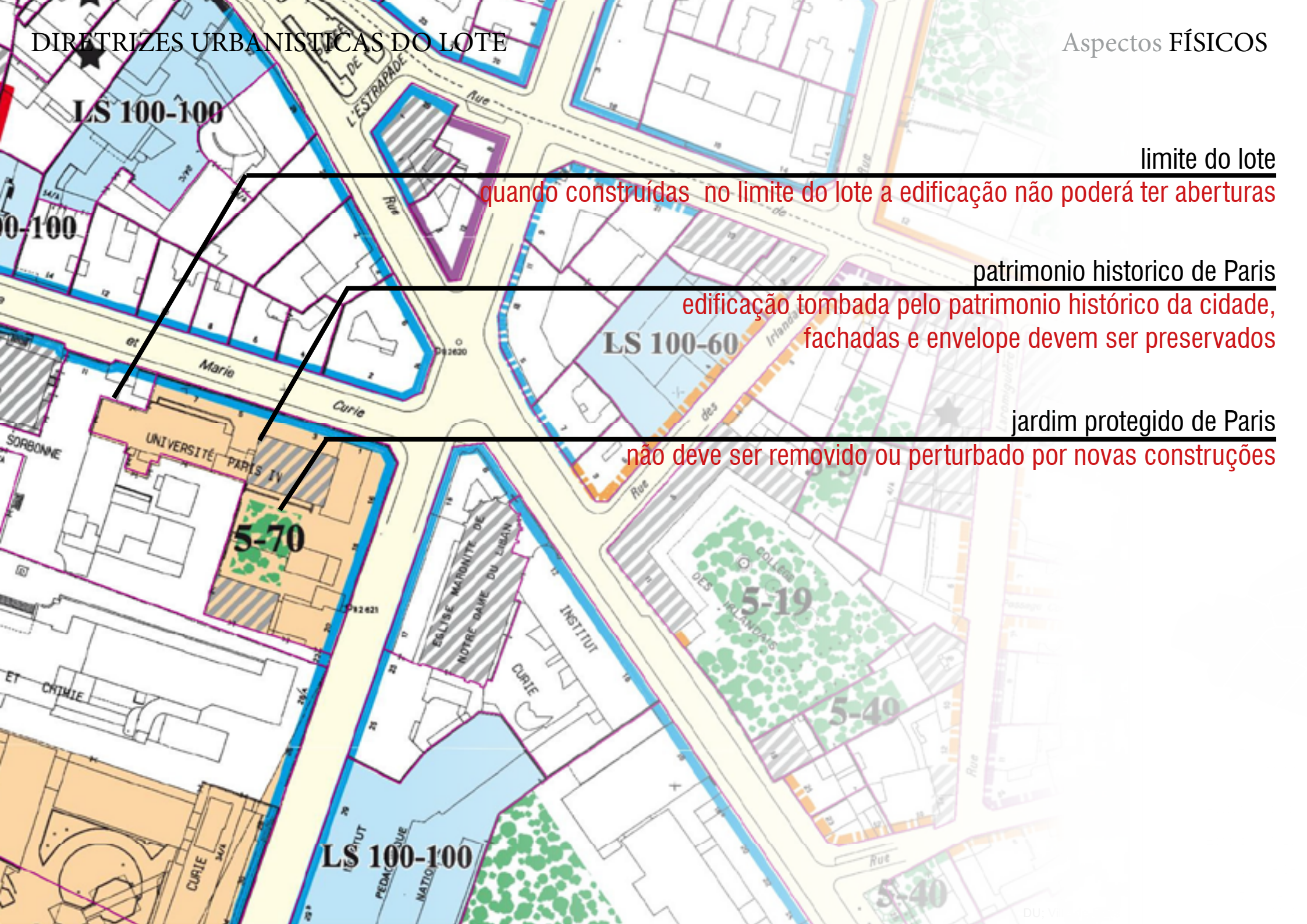

limite do lote

quando construídas no limite do lote a edificação não poderá ter aberturas

patrimônio histórico de Paris

edificação tombada pelo patrimônio histórico da cidade, fachadas e envelope devem ser preservados

jardim protegido de Paris

não deve ser removido ou perturbado por novas construções

# DIRETRIZES URBANÍSTICAS DO LOTE

## Aspectos FÍSICOS

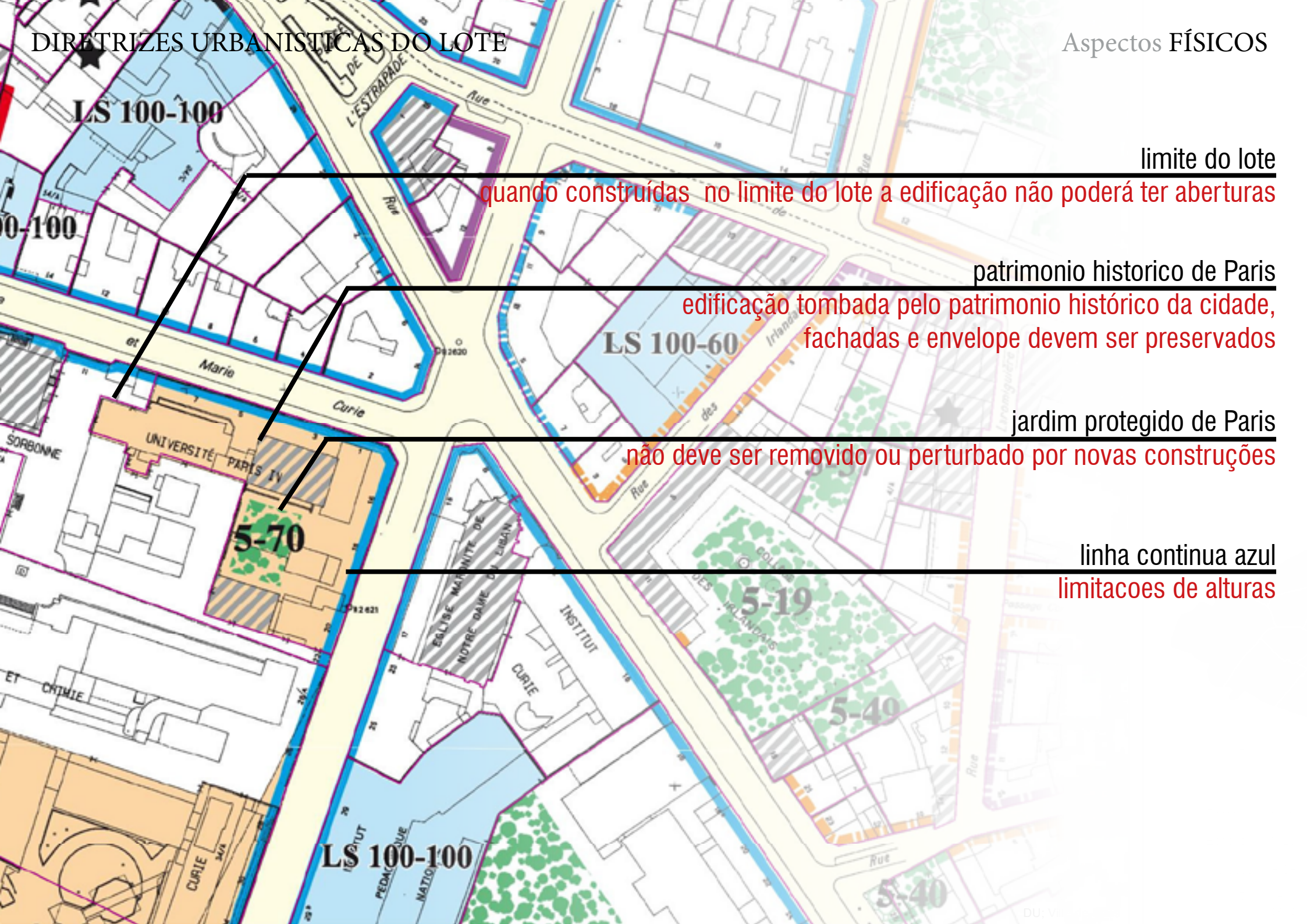

limite do lote

quando construídas no limite do lote a edificação não poderá ter aberturas

patrimônio histórico de Paris

edificação tombada pelo patrimônio histórico da cidade, fachadas e envelope devem ser preservados

jardim protegido de Paris

não deve ser removido ou perturbado por novas construções

linha contínua azul

limitações de alturas

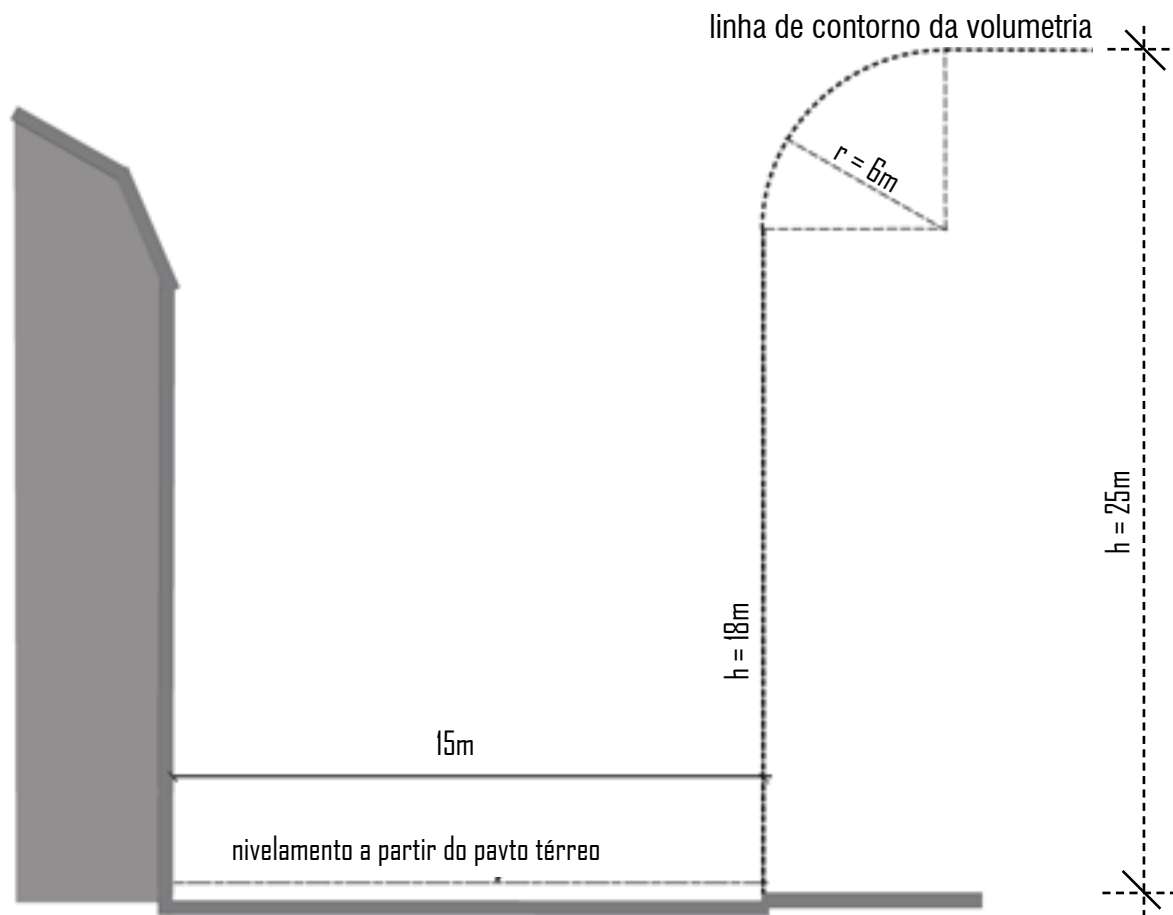

SEGUNDO ARTIGO  
10.2 DA ZONA UGSU:

*figura 08*

1 - a linha azul clara permite construções de no máximo **18m** de altura junto ao alinhamento predial

2 - a linha colorida de alinhamento quando continua permite um **coroaamento de raio = 6m**

# ANÁLISE DO ENTORNO

# Aspectos FÍSICOS



Localização:  
18, rua d'ULM  
5° arrondissement  
Paris - FR

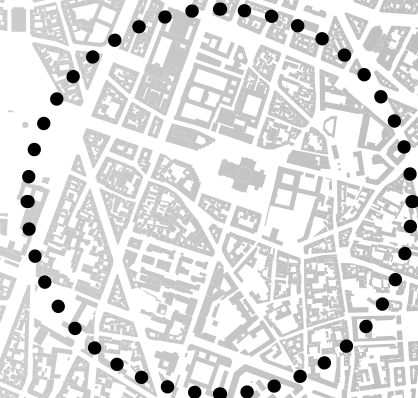





Localização:  
18, rua d'ULM  
5° arrondissement  
Paris - FR

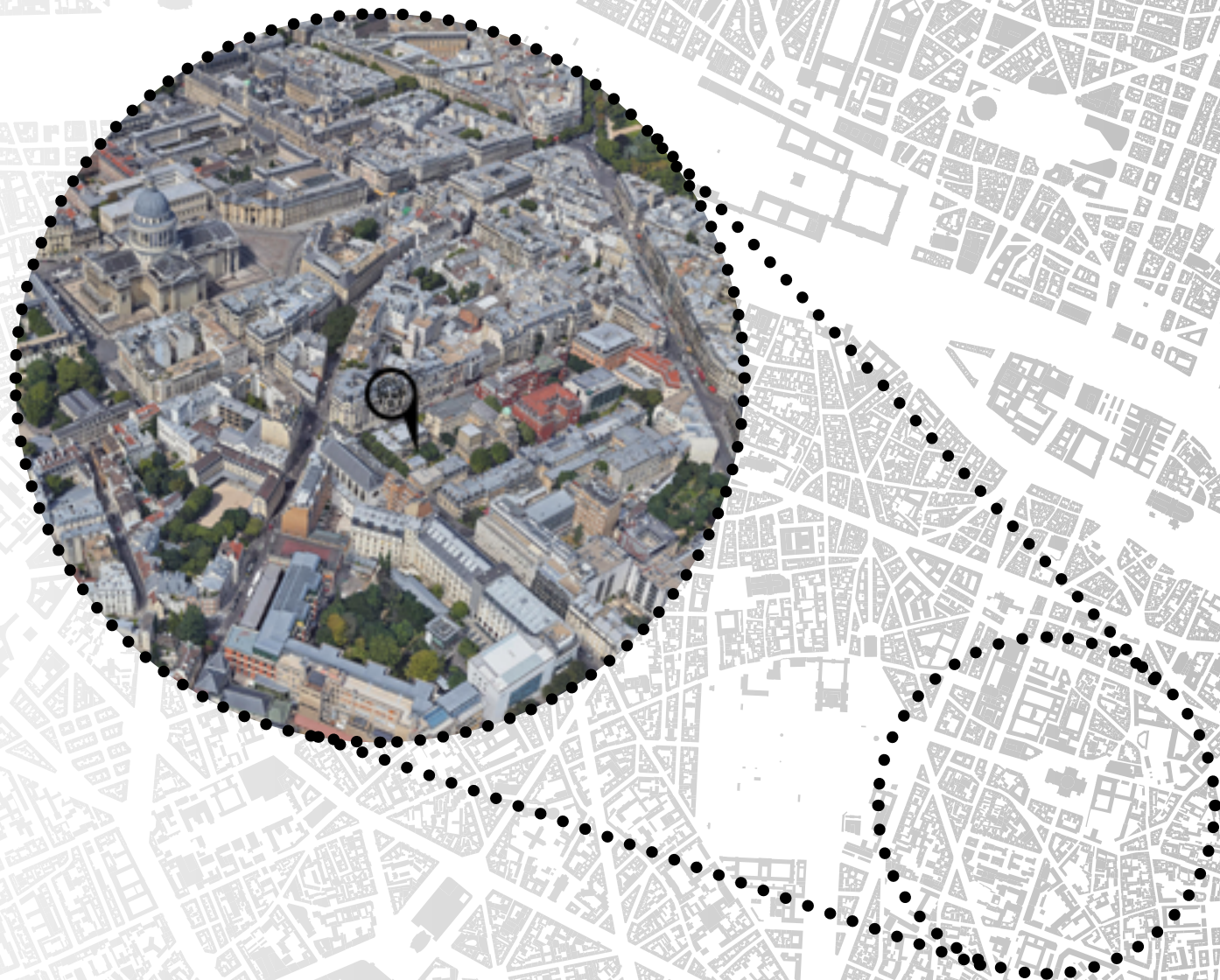

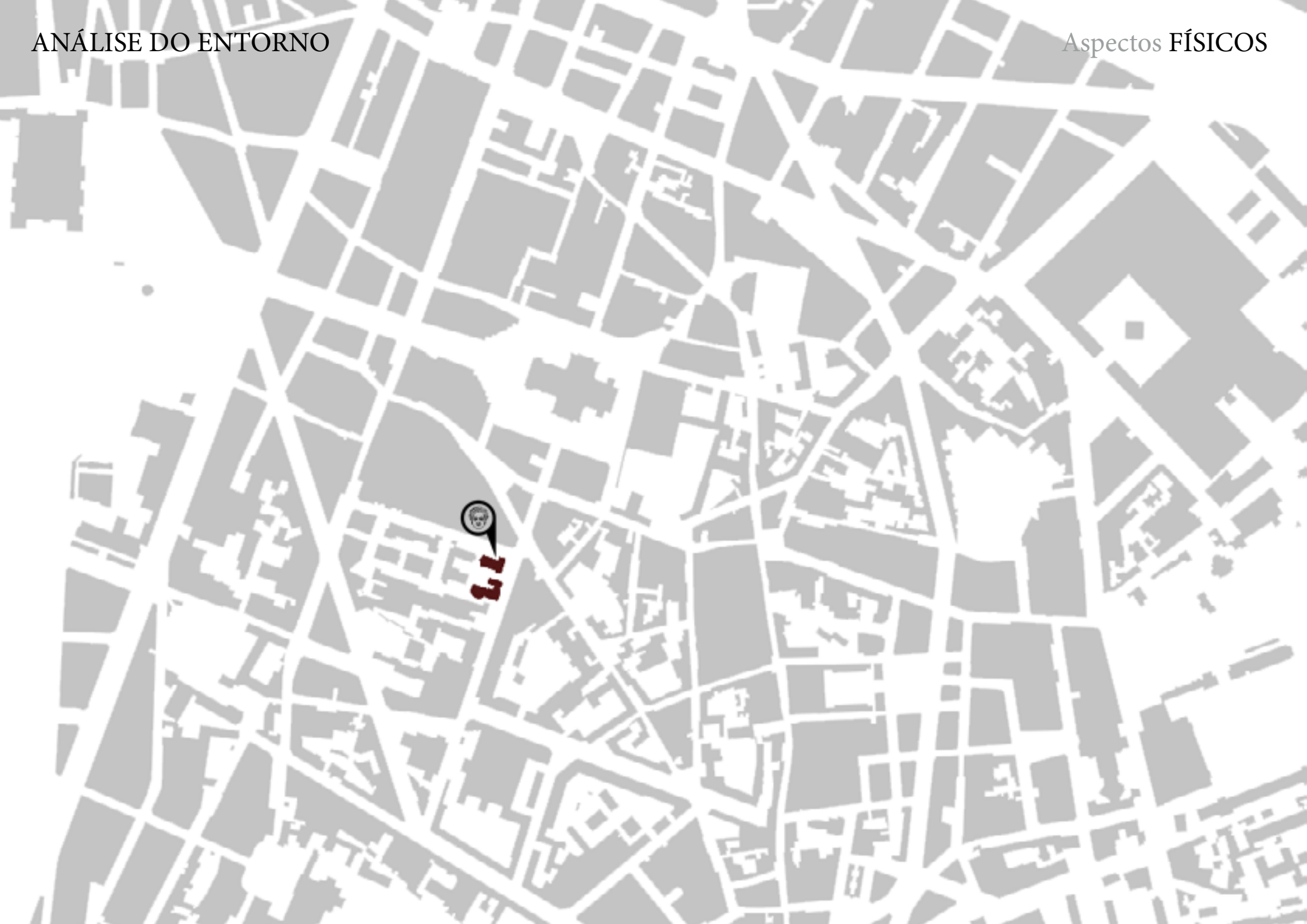

# ANÁLISE DO ENTORNO

JARDIN  
LUXENBURGO

BIBLIOTECA  
S GENEVIEVE

UNI UPMC

MUSEU  
PANTHEON

LYCEE  
HENRI V

POI ITTCNICA  
BIOLOGIA

POI ITTCNICA  
ARTS ET METIERS

POLITECNICA  
QUIMICA

ECOLE SUP.  
NORMAL

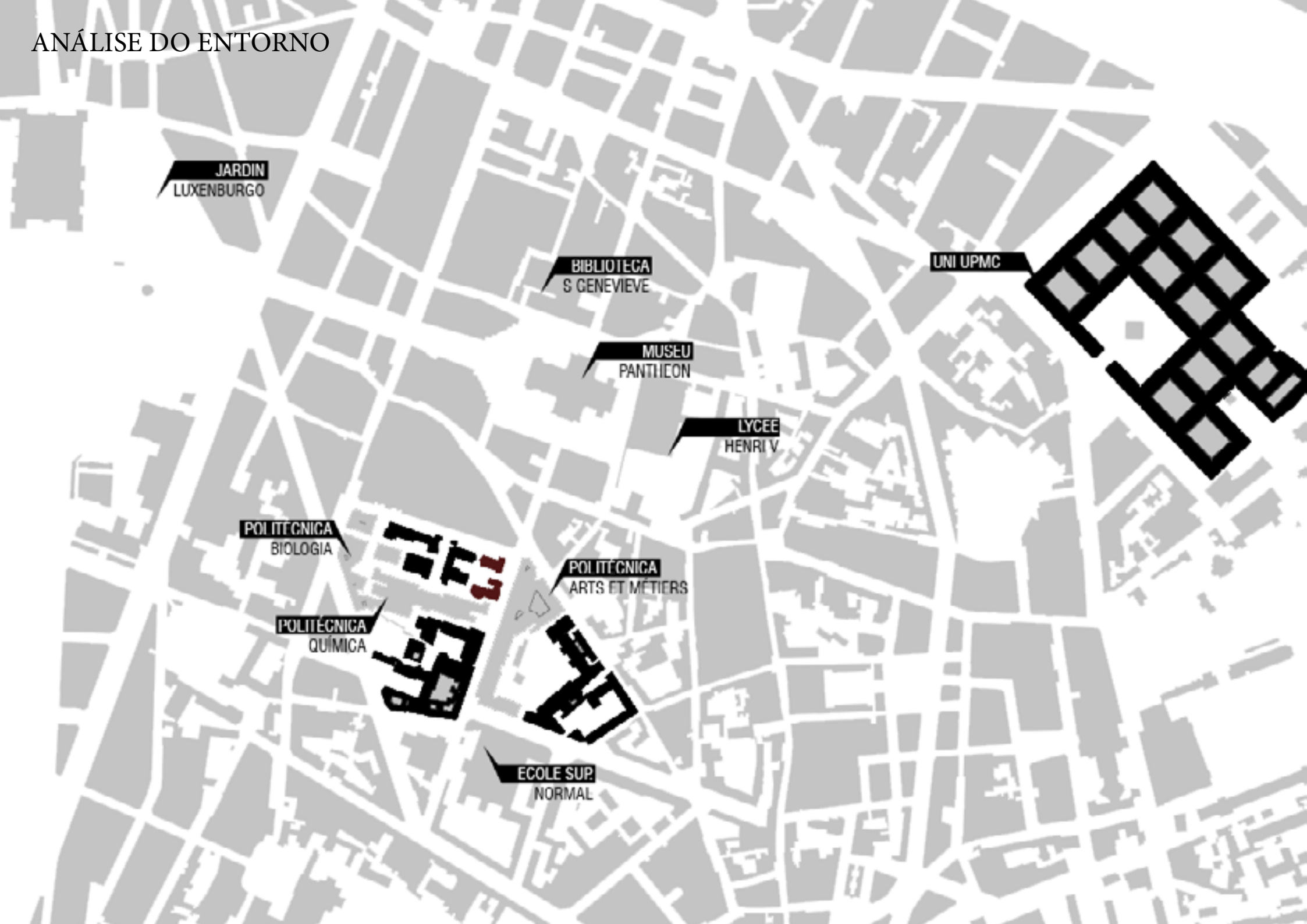

 PONTOS DE METRO

**711**

650m

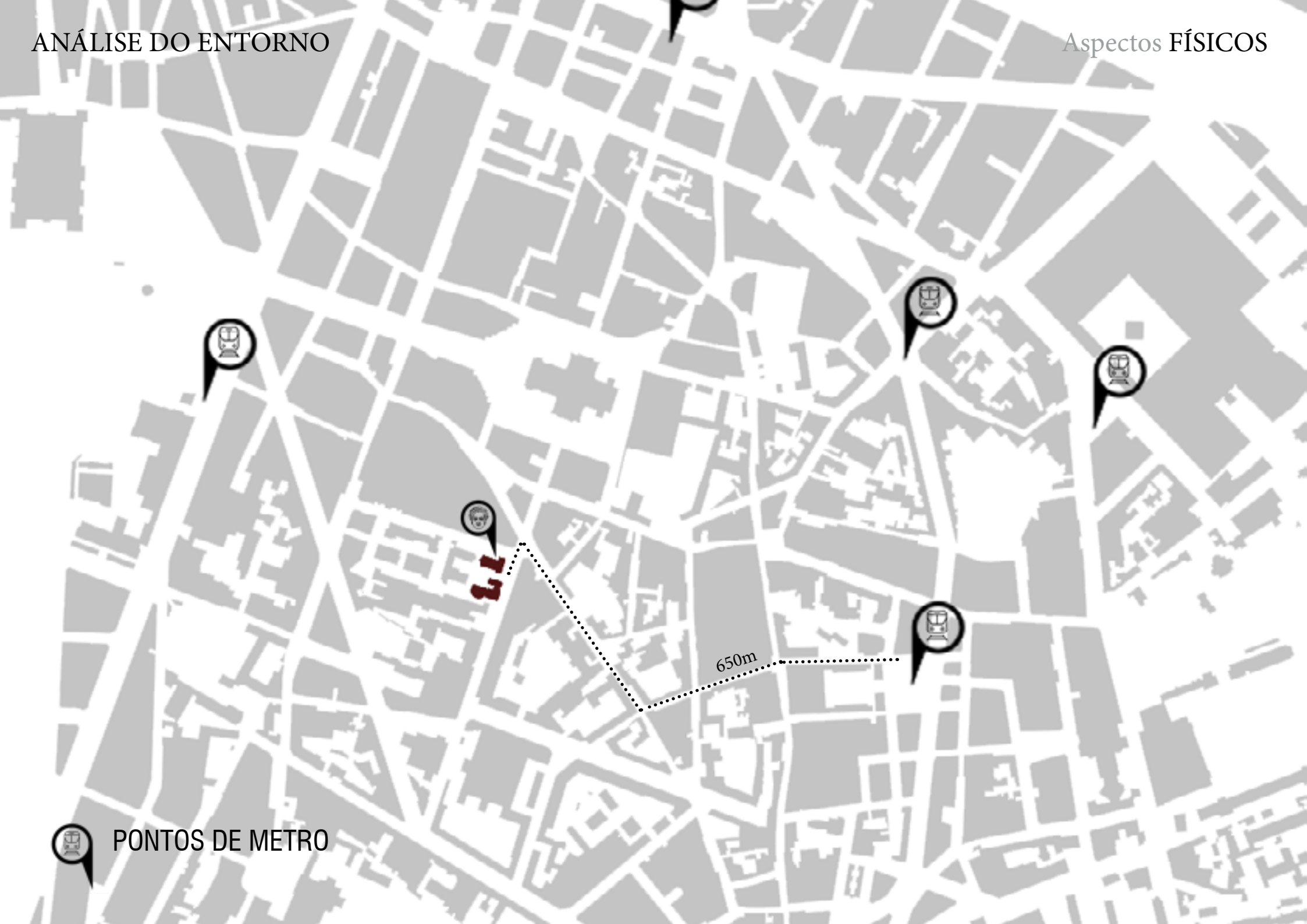



PONTOS DE ONIBUS

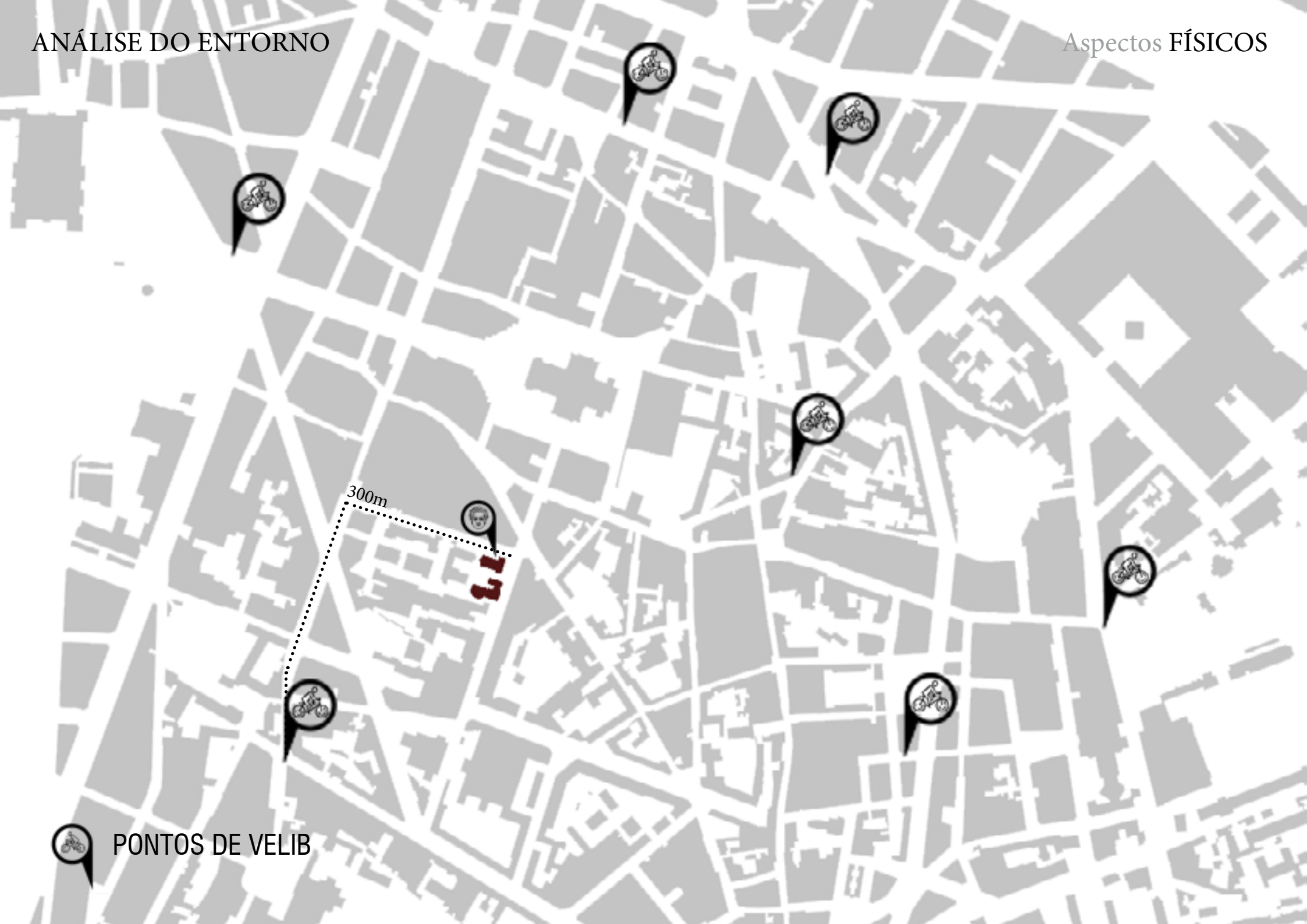

 PONTOS DE VELIB

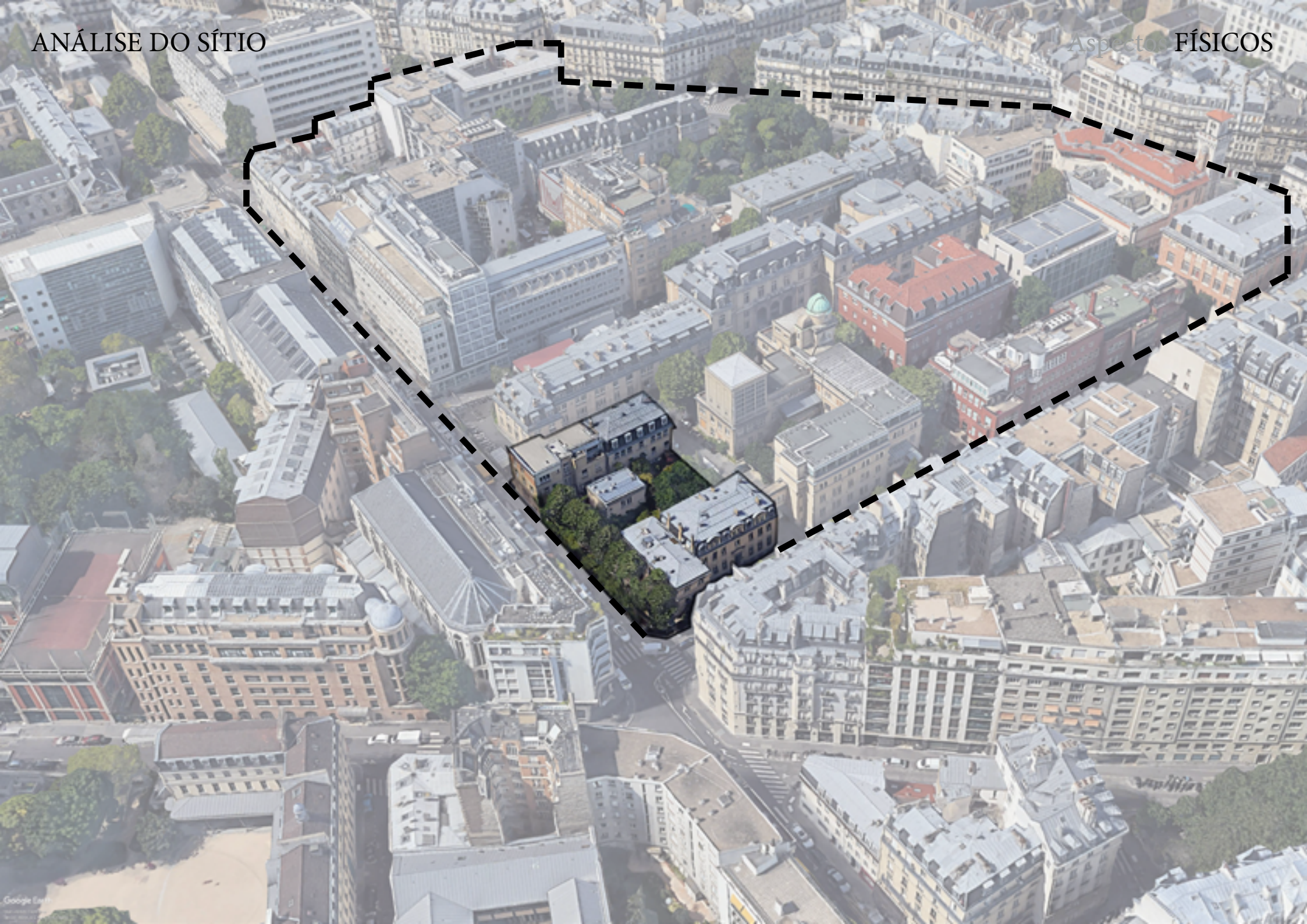

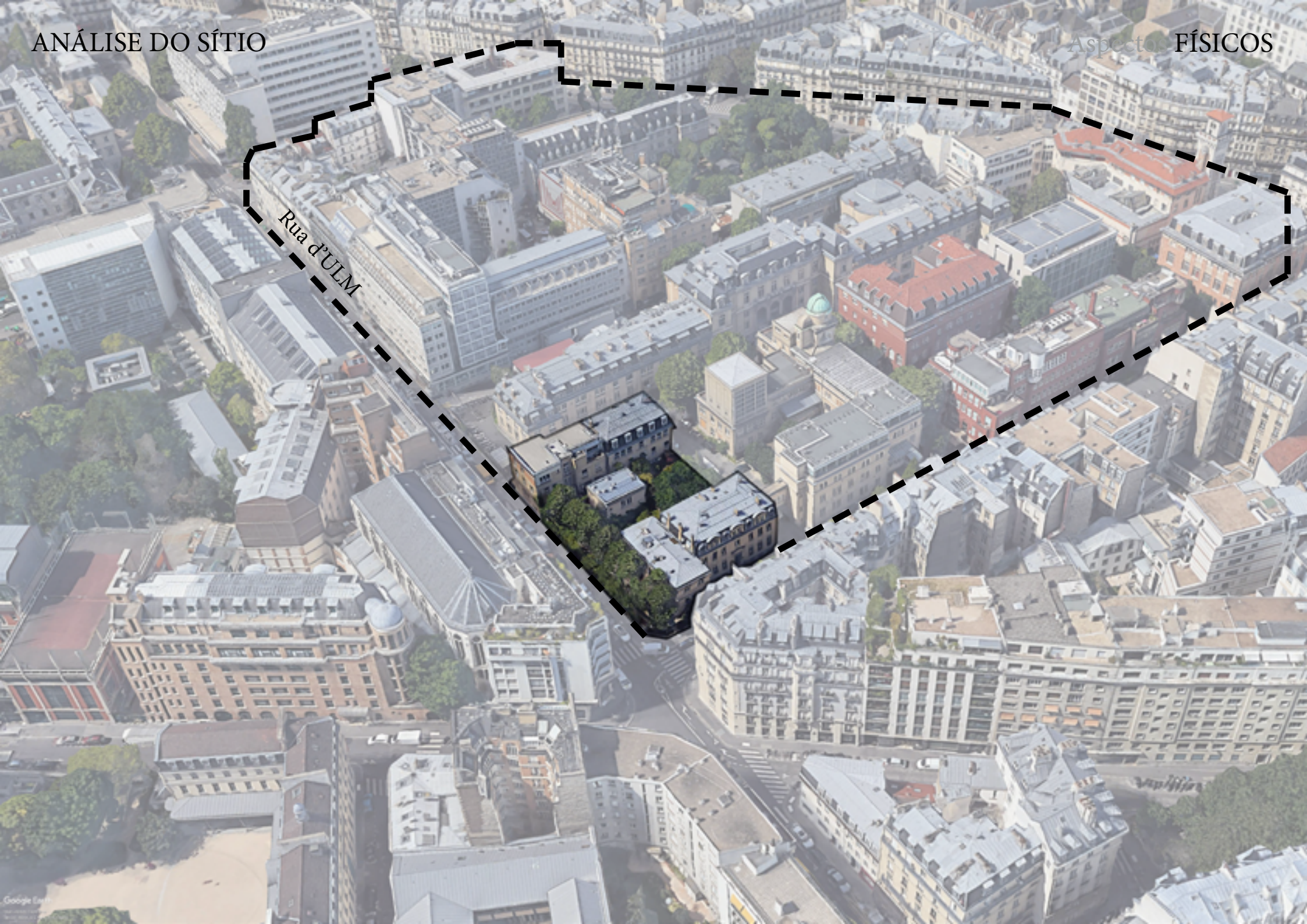

Rua d'ULM



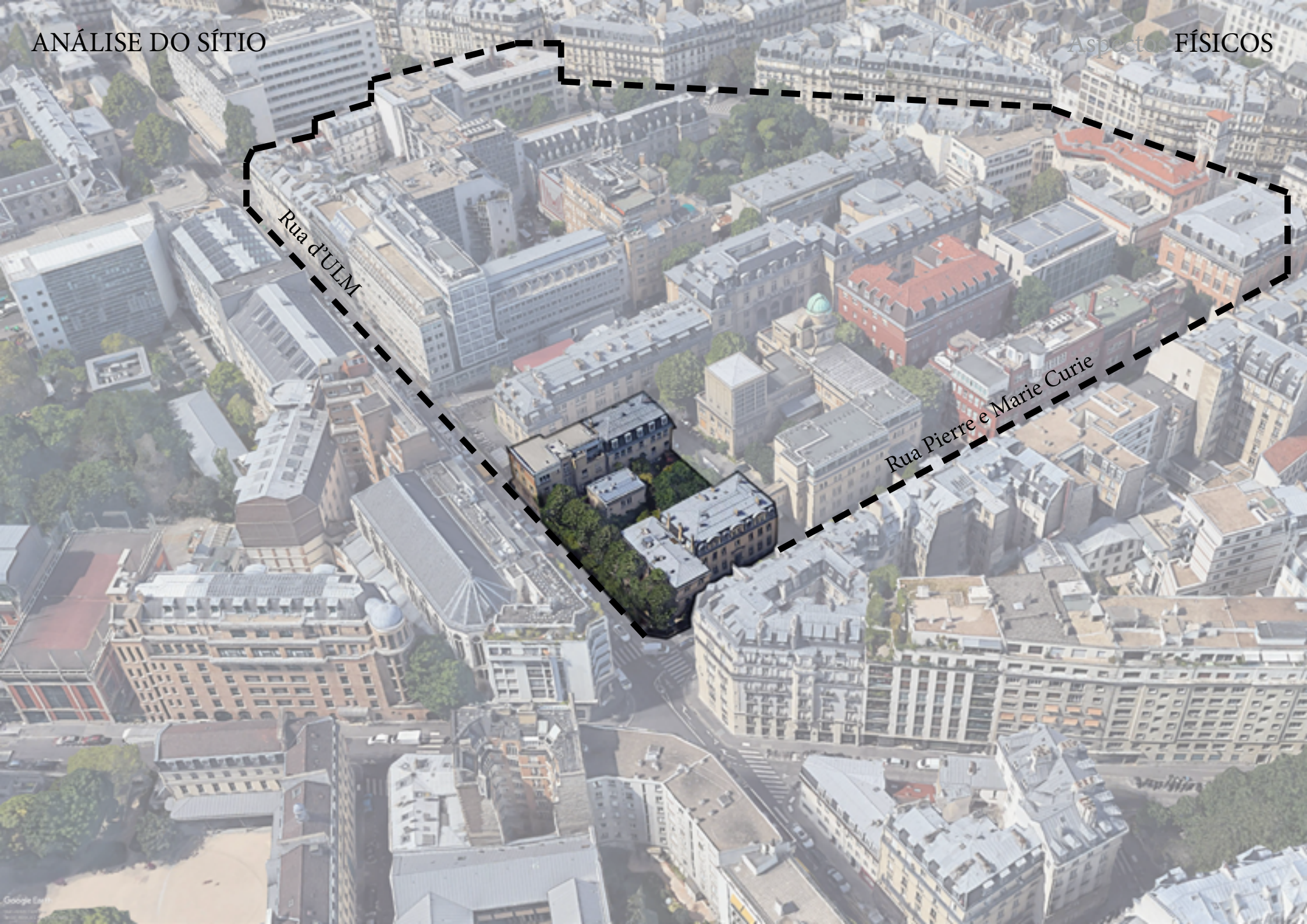

Rua d'ULM

Rua Pierre e Marie Curie

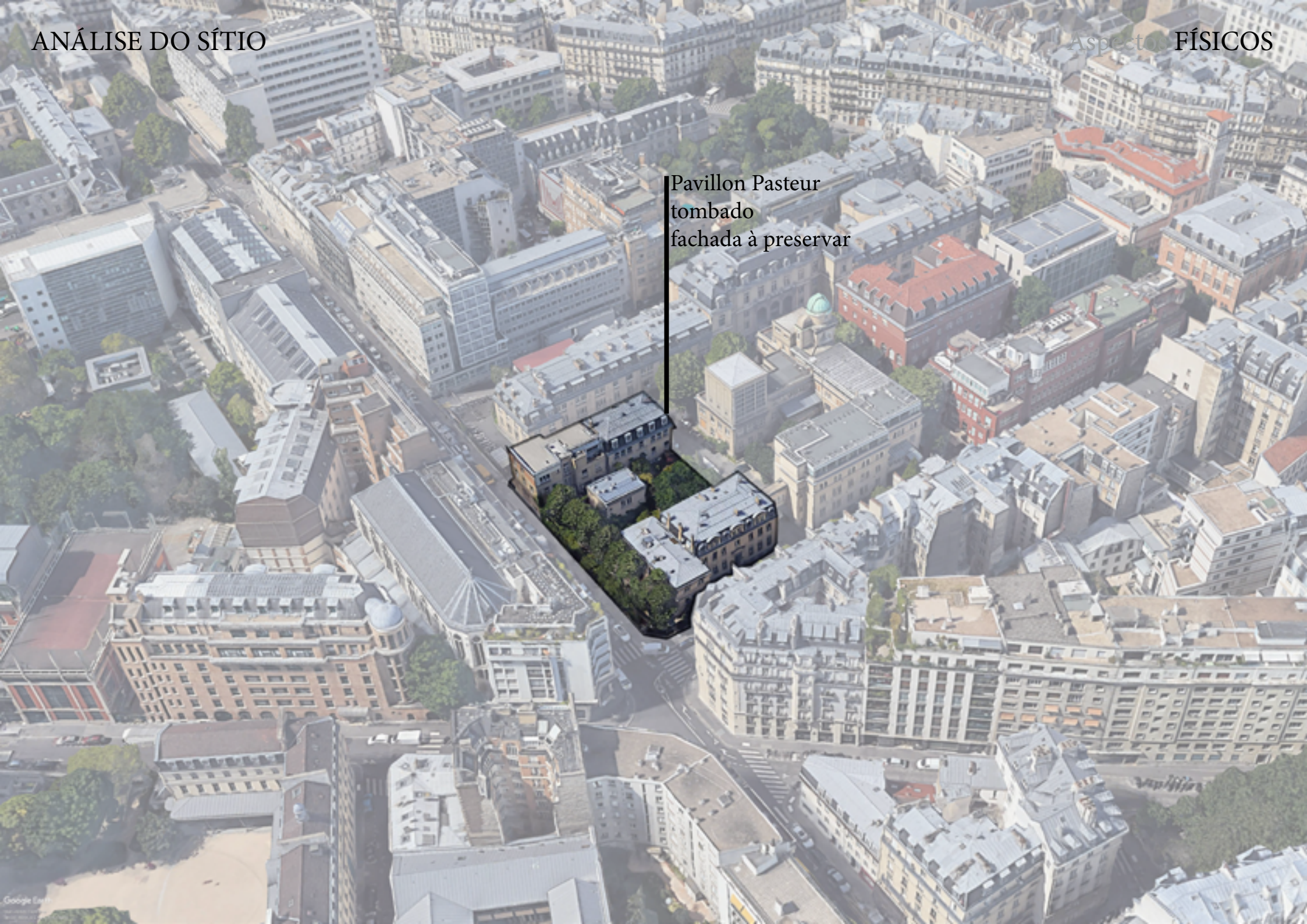

Pavillon Pasteur  
tombado  
fachada à preservar

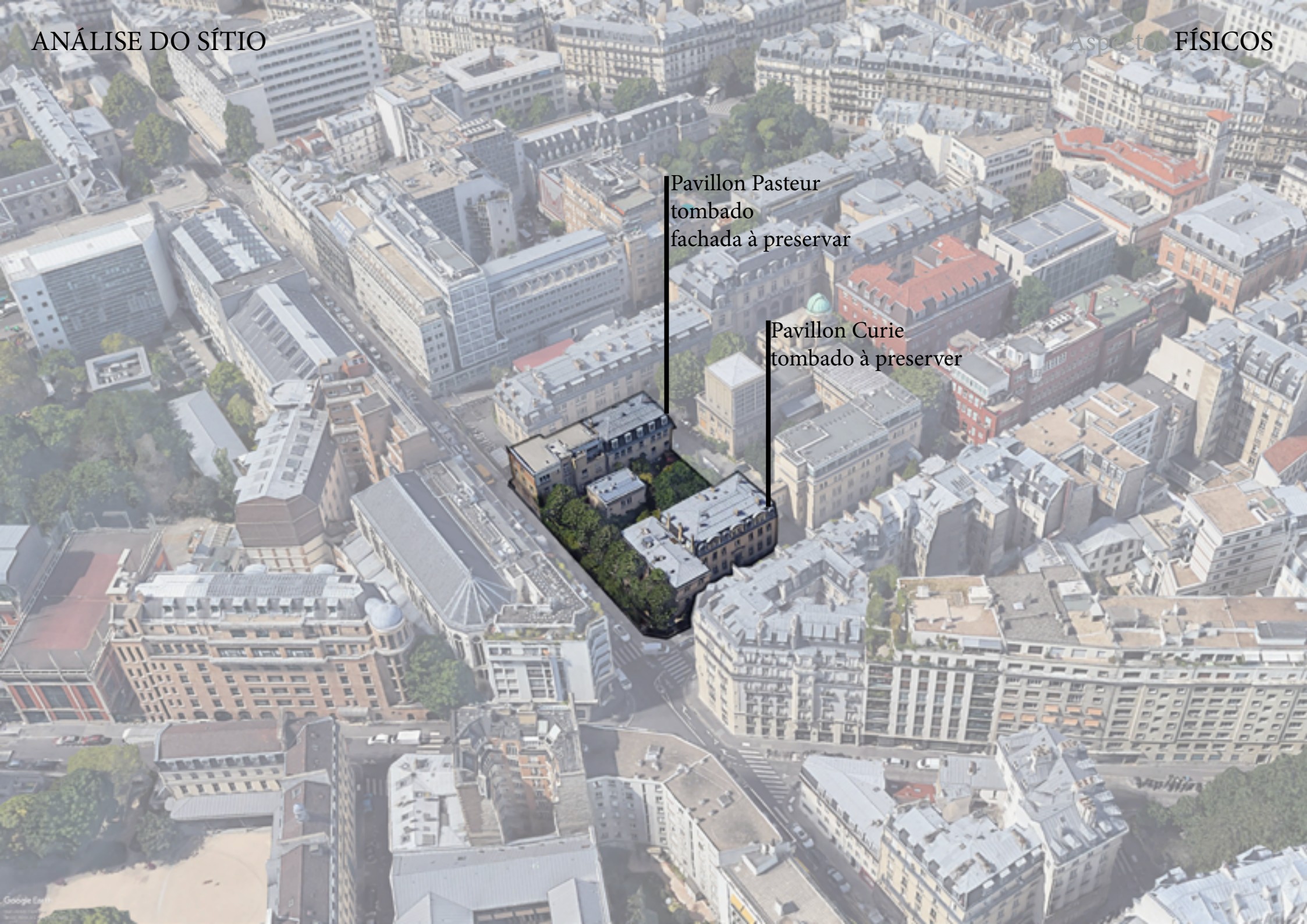

Pavillon Pasteur  
tombado  
fachada à preservar

Pavillon Curie  
tombado à preservar

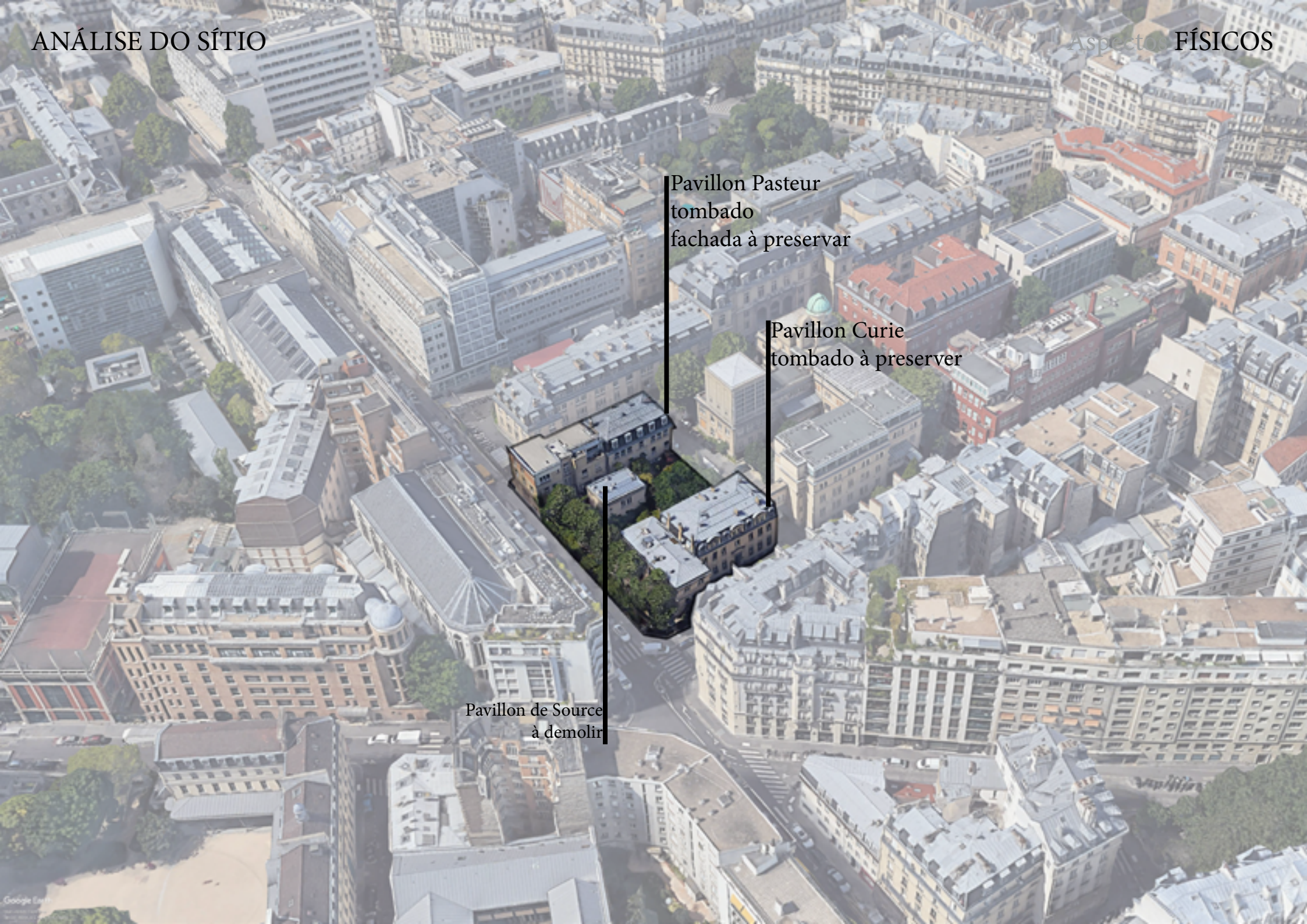

Pavillon Pasteur  
tombado  
fachada à preservar

Pavillon Curie  
tombado à preservar

Pavillon de Source  
à demolir

Extensão  
Pavillon Pasteur  
à modificar

Pavillon Pasteur  
tombado  
fachada à preservar

Pavillon Curie  
tombado à preservar

Pavillon de Source  
à demolir

Extensão  
Pavillon Pasteur  
à modificar

Pavillon Pasteur  
tombado  
fachada à preservar

Pavillon Curie  
tombado à preservar

Pavillon de Source  
à demolir

Extensão  
Pavillon Curie  
à preservar

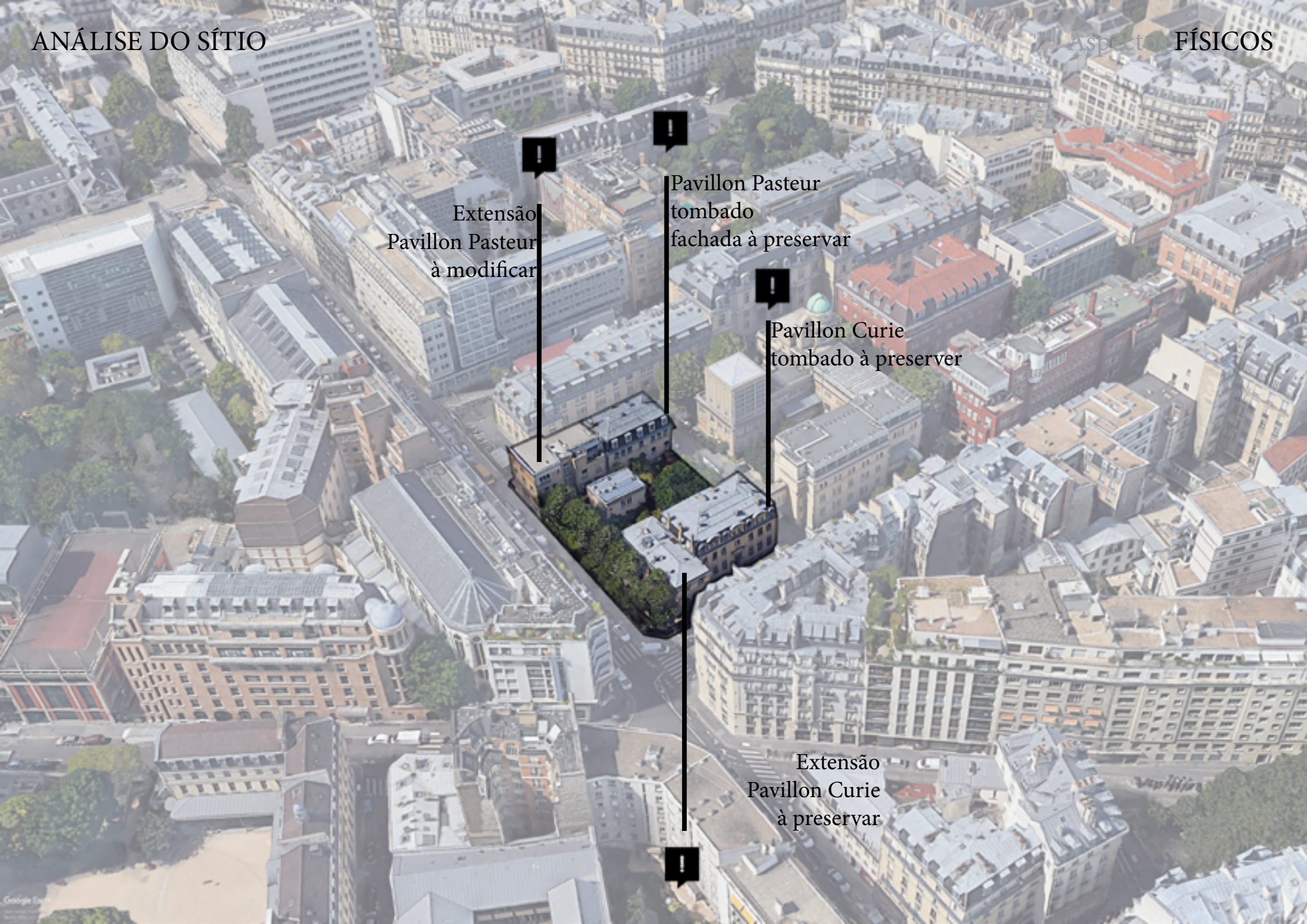

Extensão  
Pavillon Pasteur  
à modificar

Pavillon Pasteur  
tombado  
fachada à preservar

Pavillon Curie  
tombado à preservar

Extensão  
Pavillon Curie  
à preservar

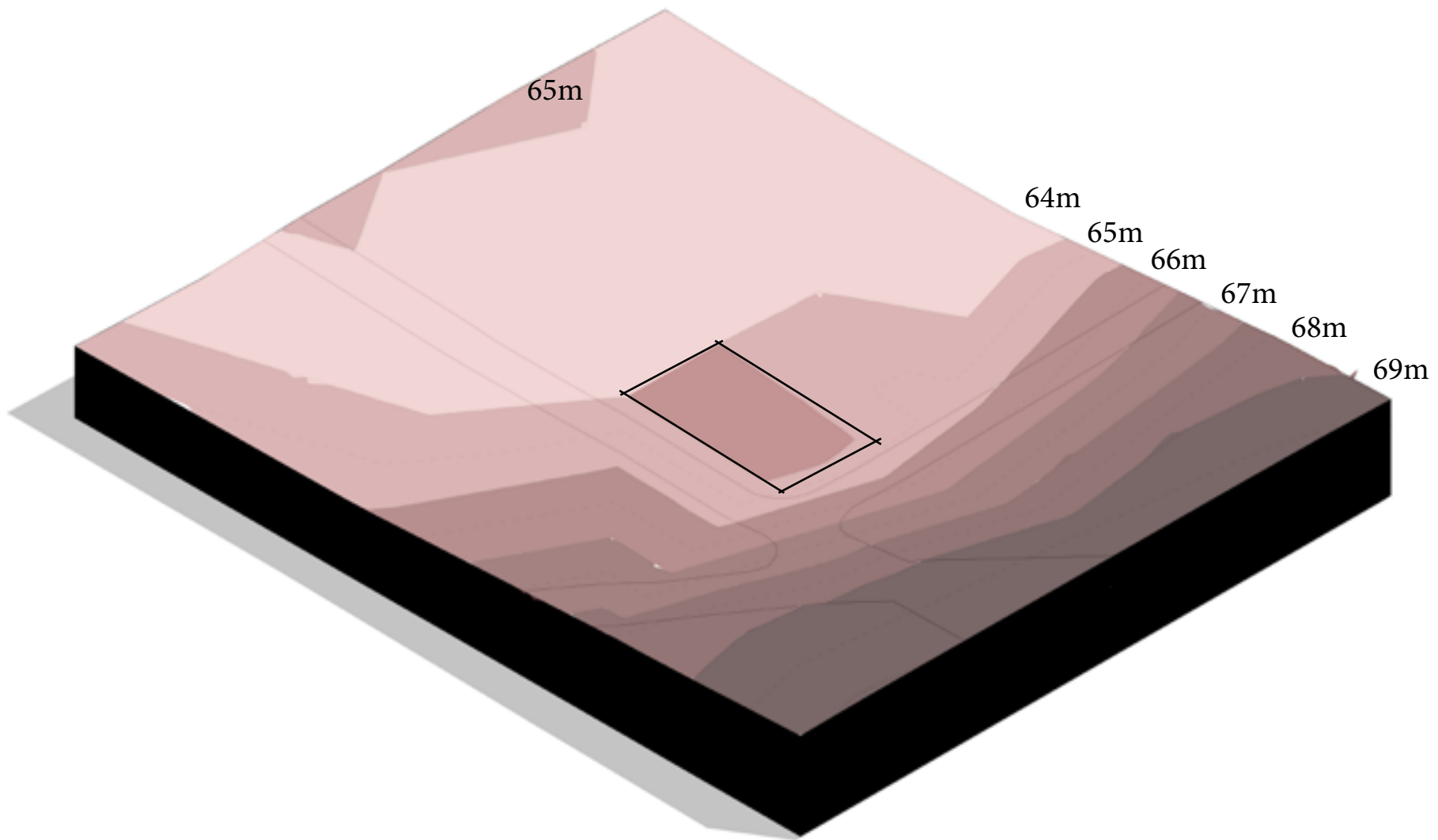



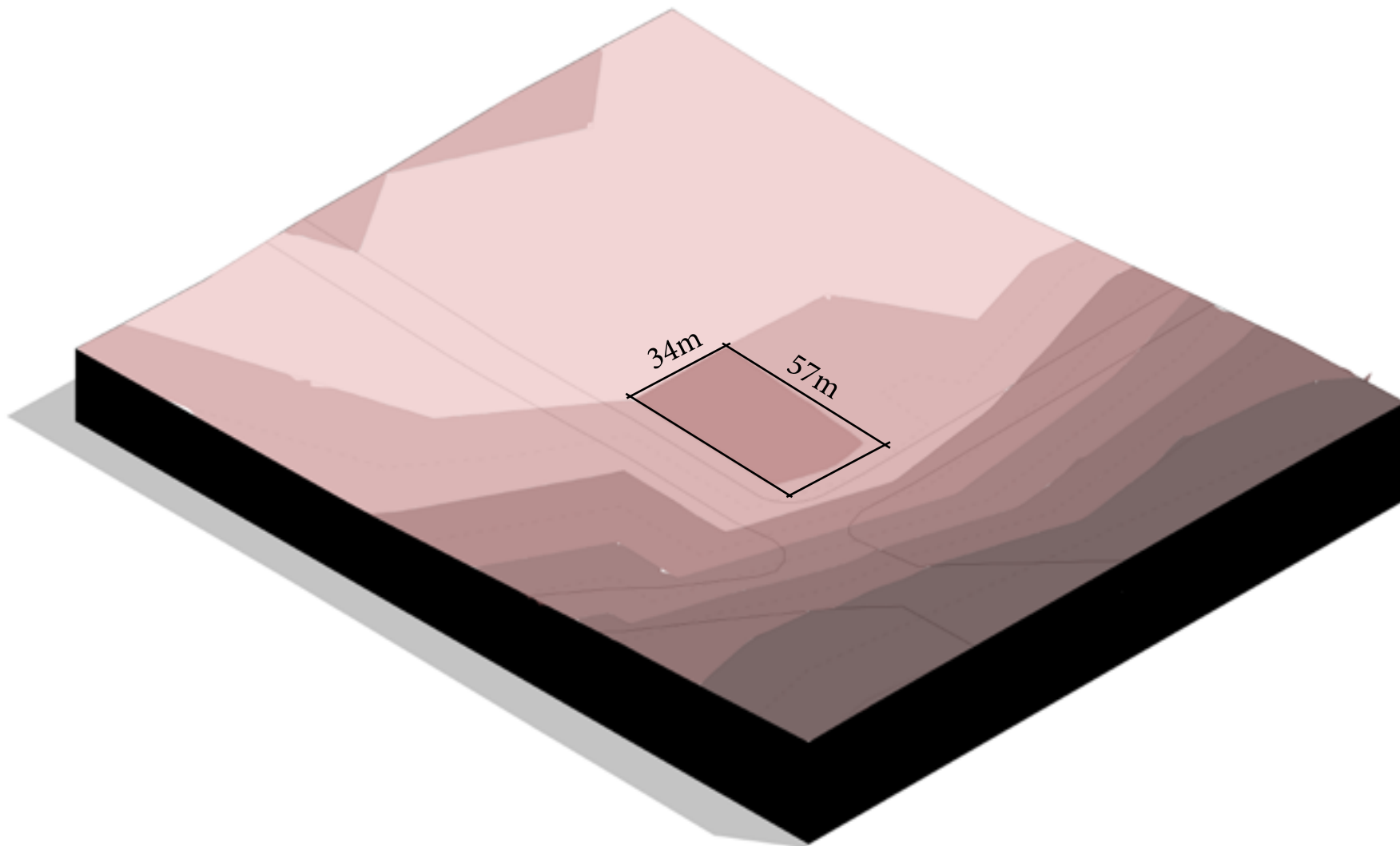

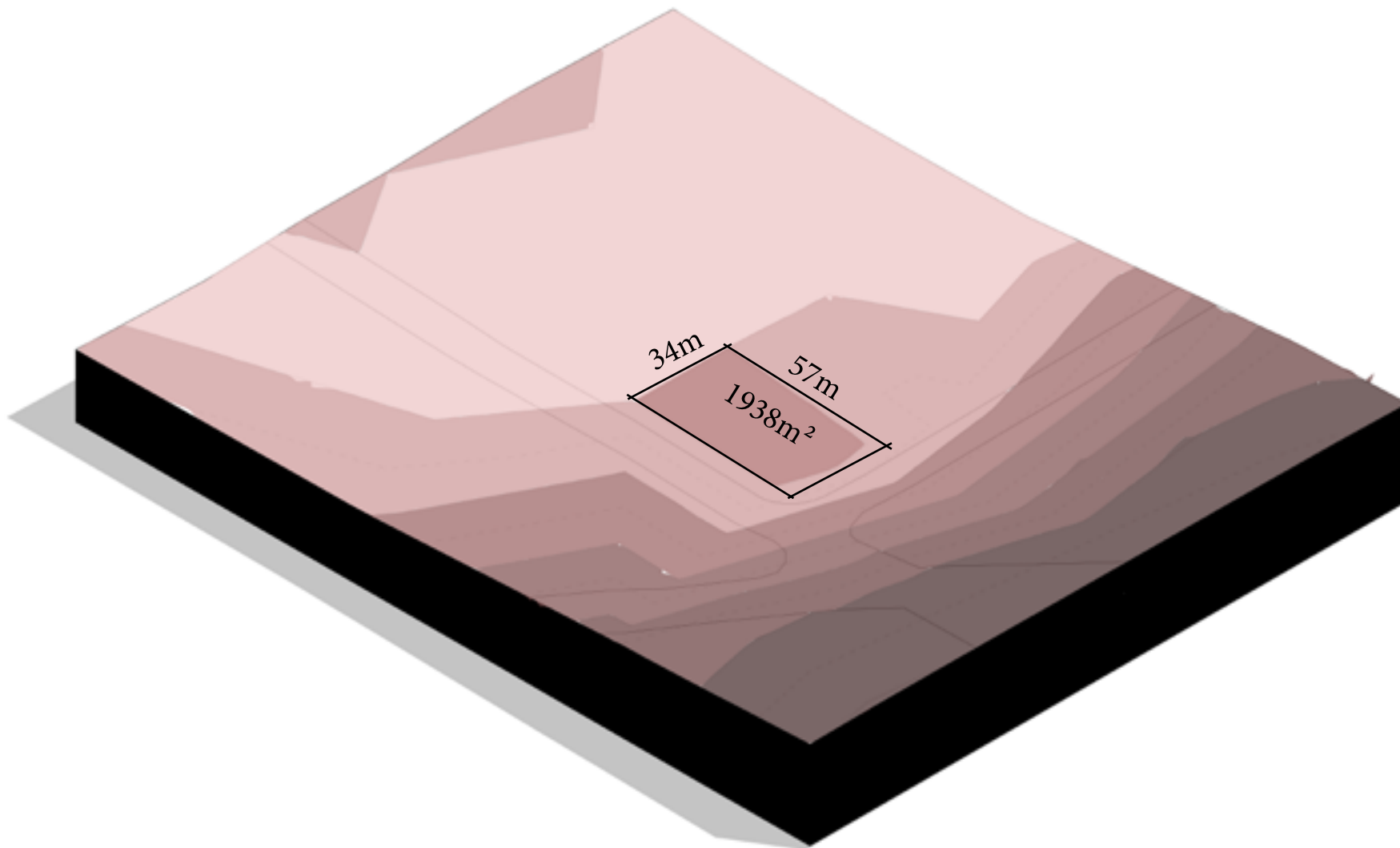

ANÁLISE INVERNO

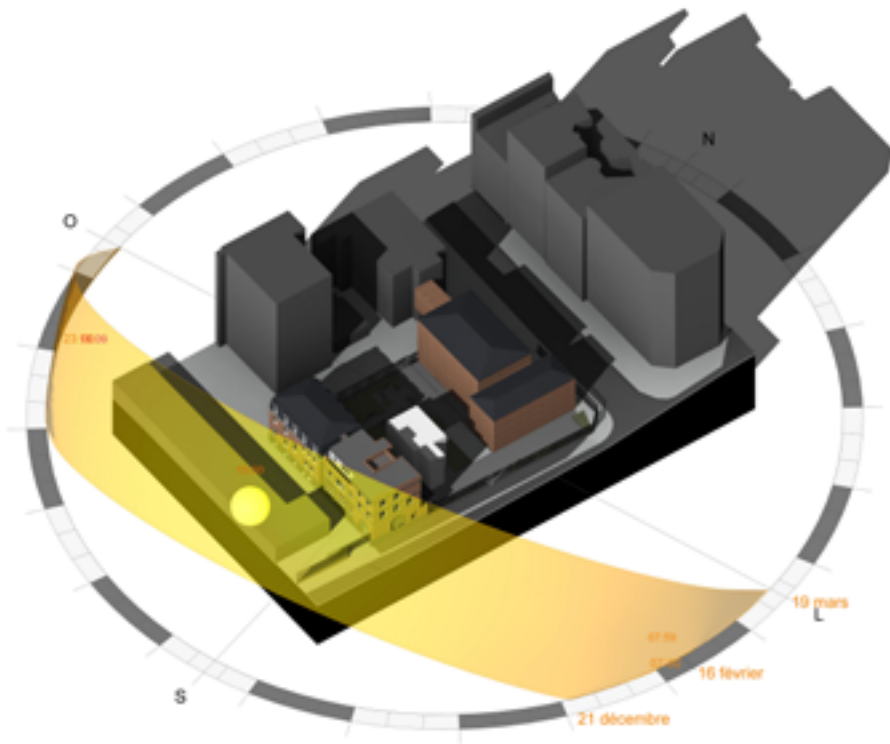

ANÁLISE VERÃO

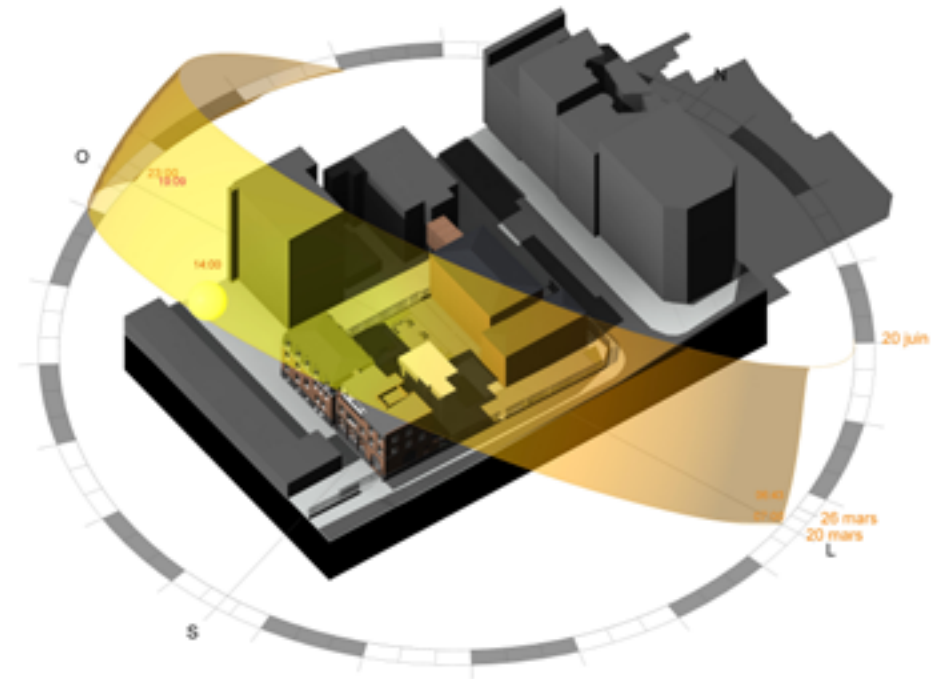



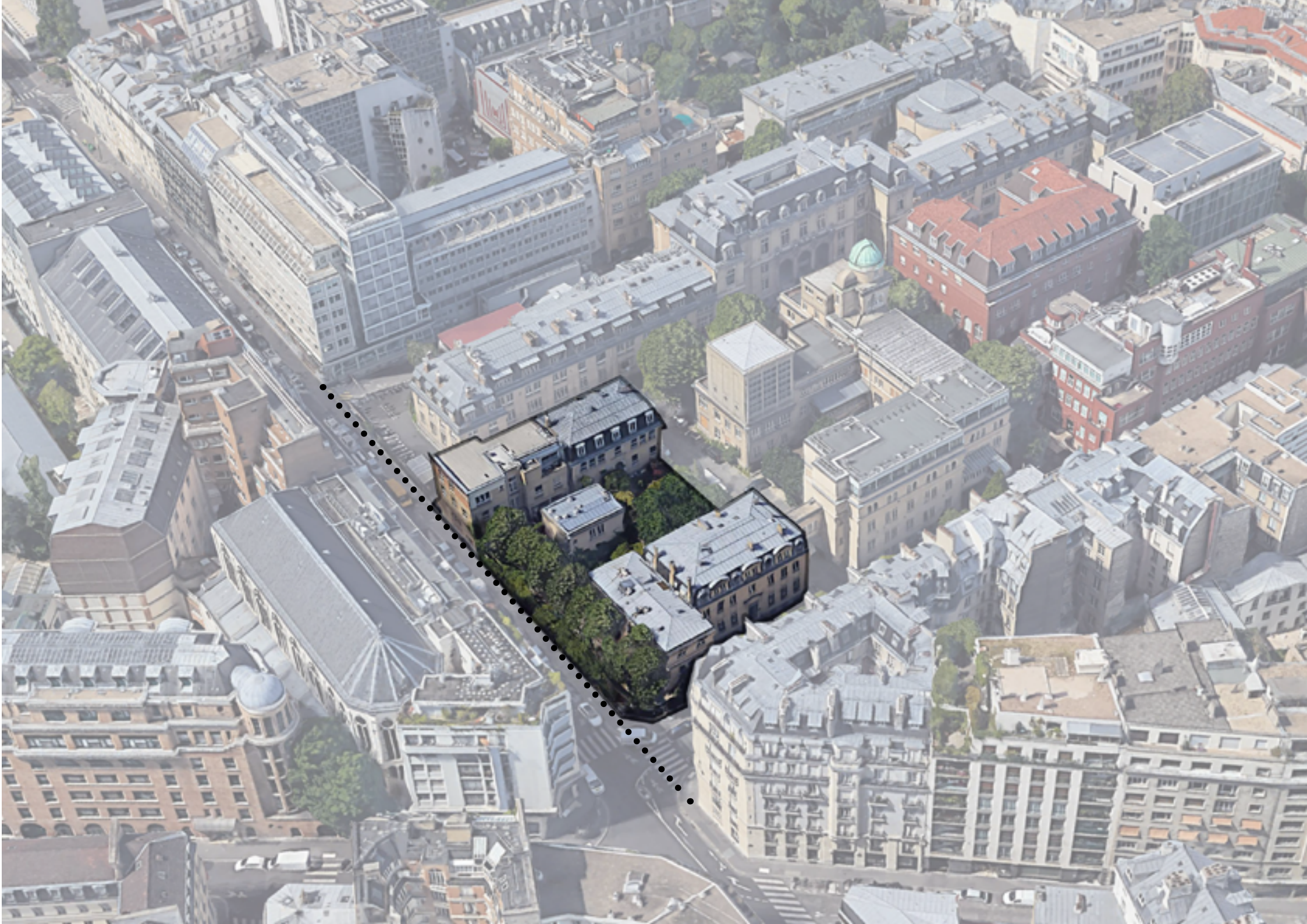

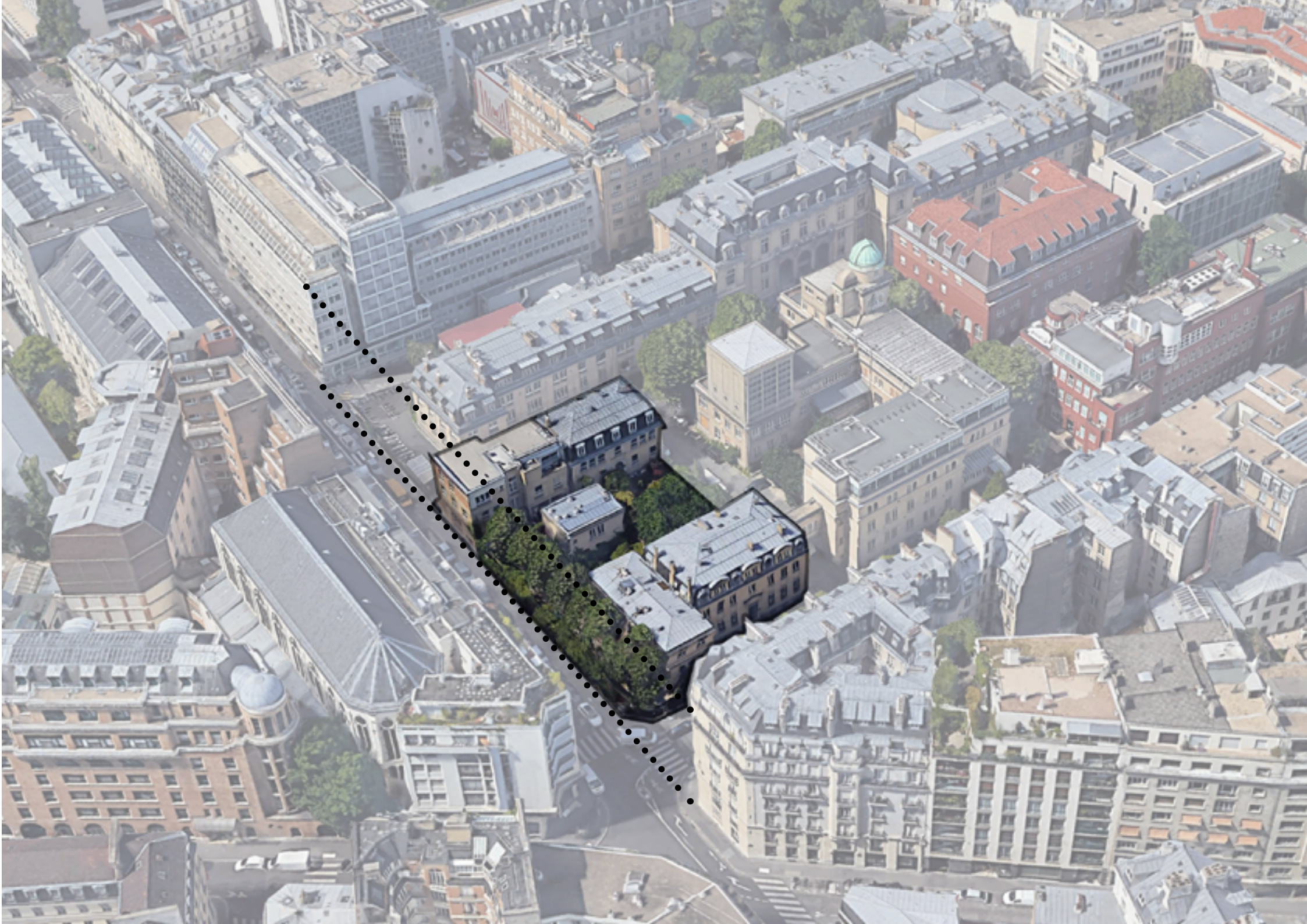

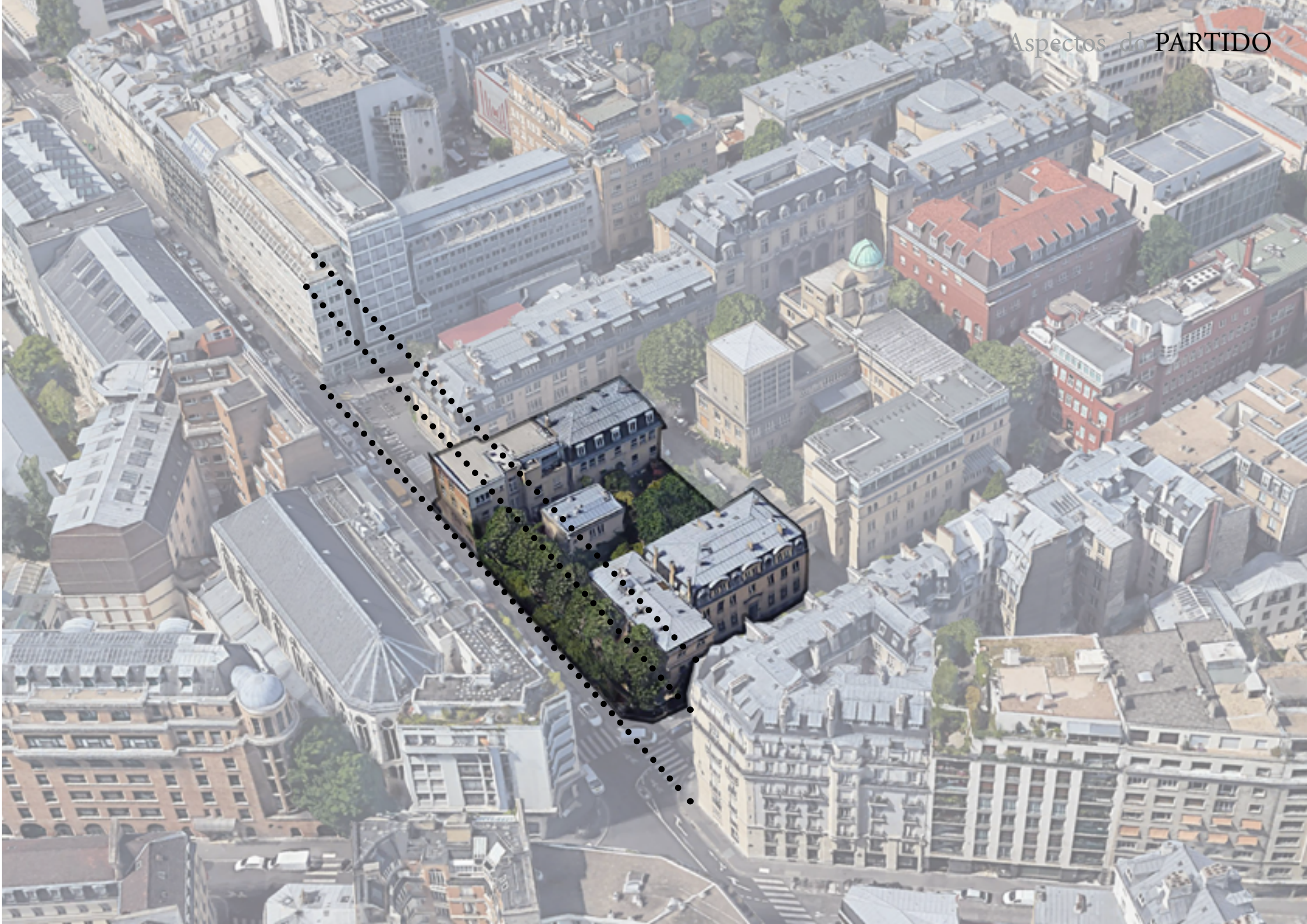

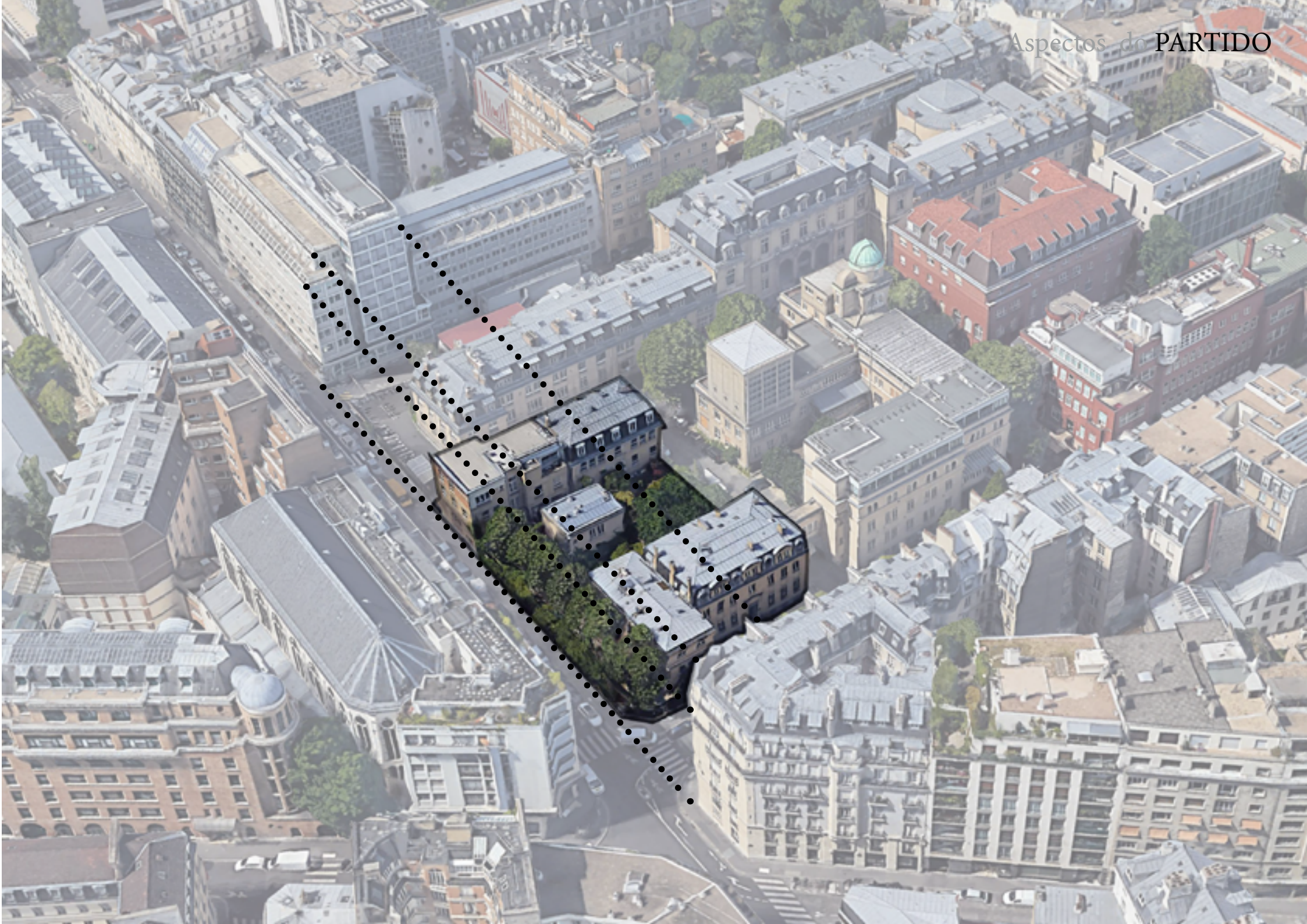



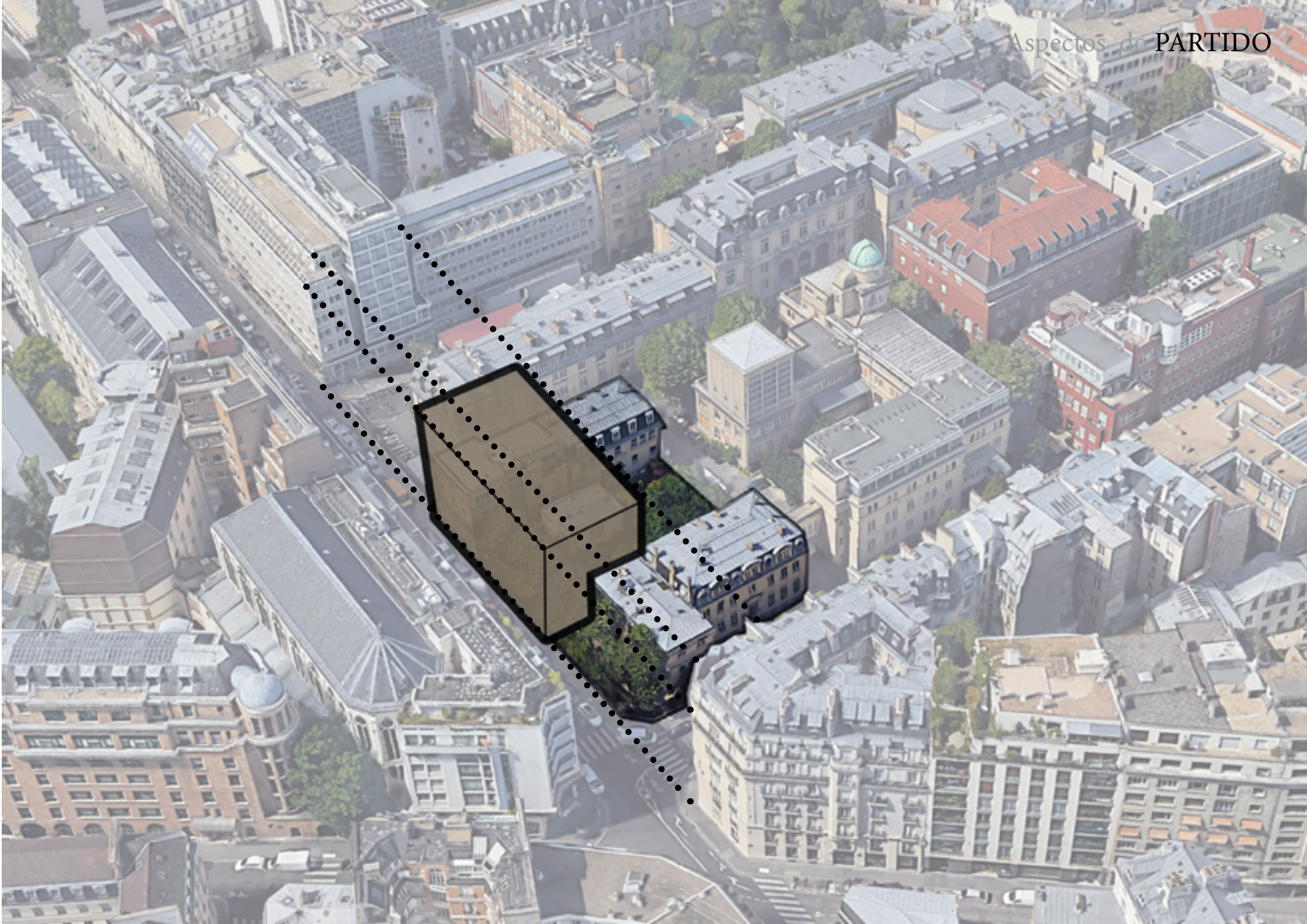

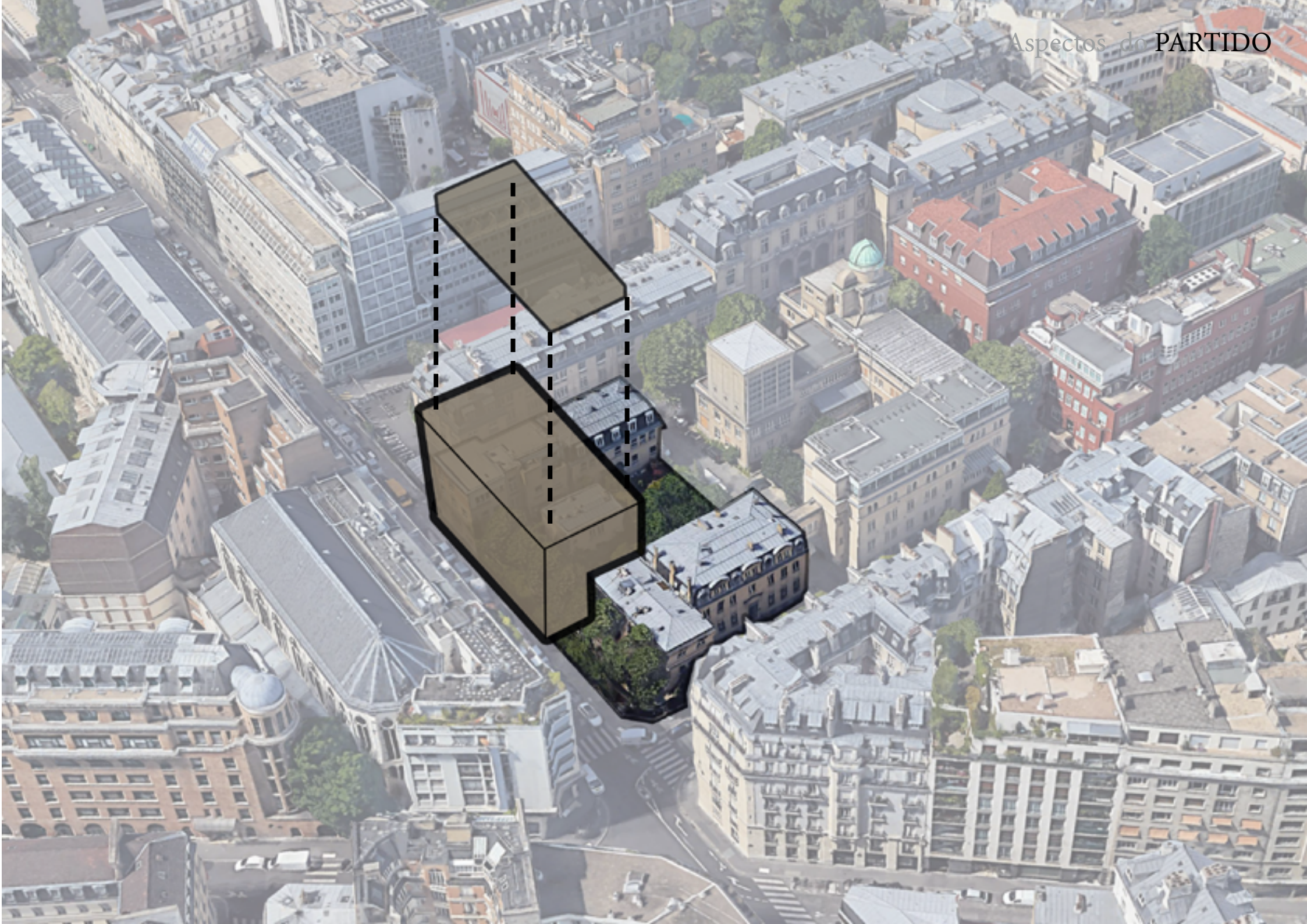





Coroamento em vidro

Casca em ripas de madeira horizontal com dimensão e coloração aproximada ao do tijolo

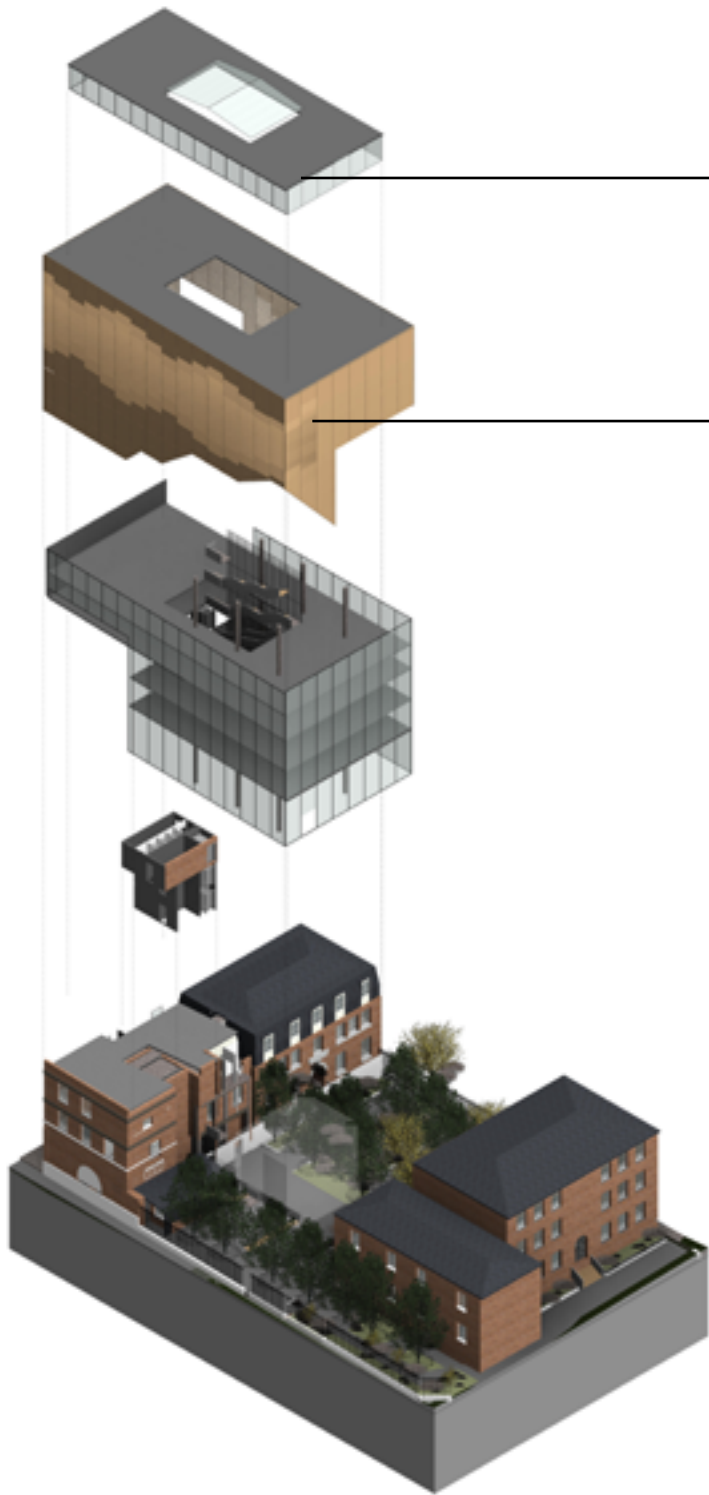

Coroamento em vidro

Casca em ripas de madeira horizontal com dimensão e coloração aproximada ao do tijolo

Andares e esquadrias em pele de vidro

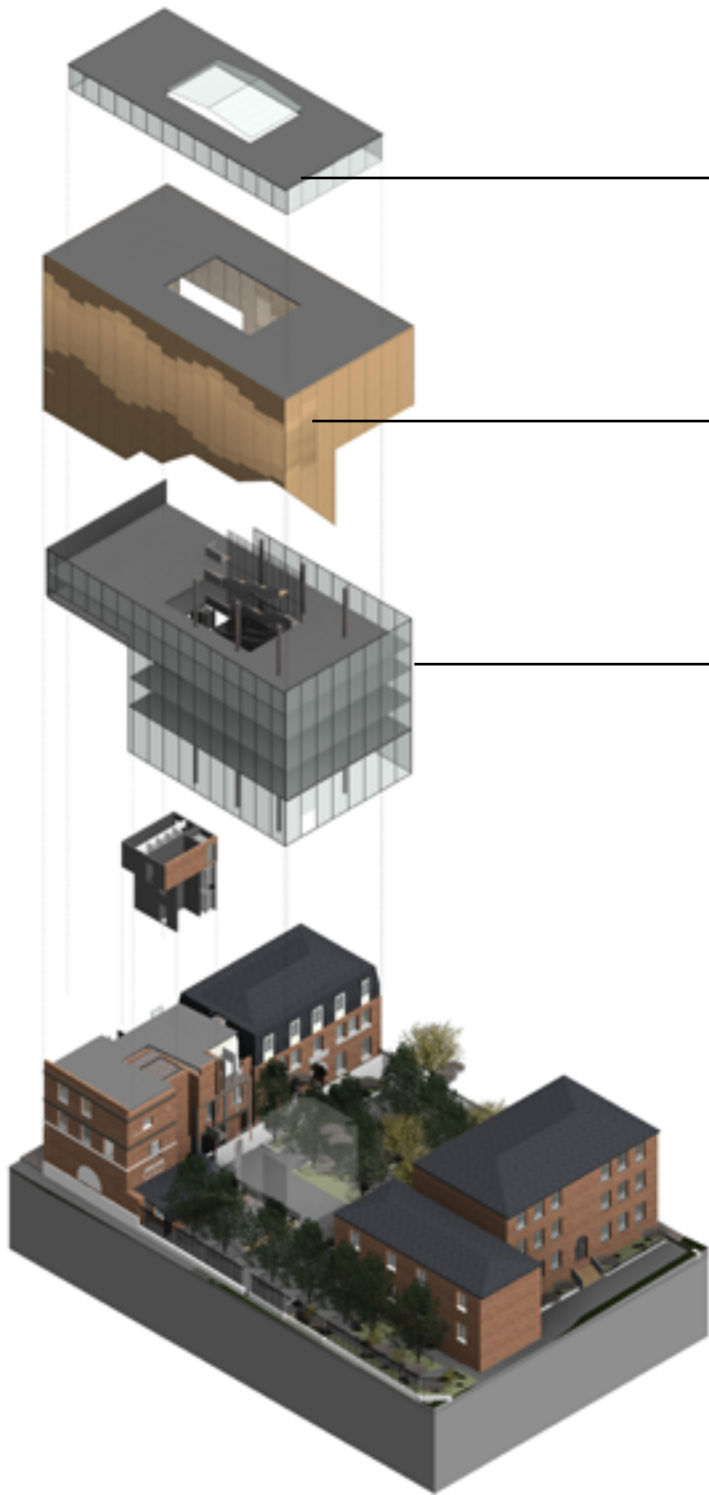

Coroamento em vidro

Casca em ripas de madeira horizontal com dimensão e coloração aproximada ao do tijolo

Andares e esquadrias em pele de vidro

Núcleo de serviços sobreposto ao núcleo existente

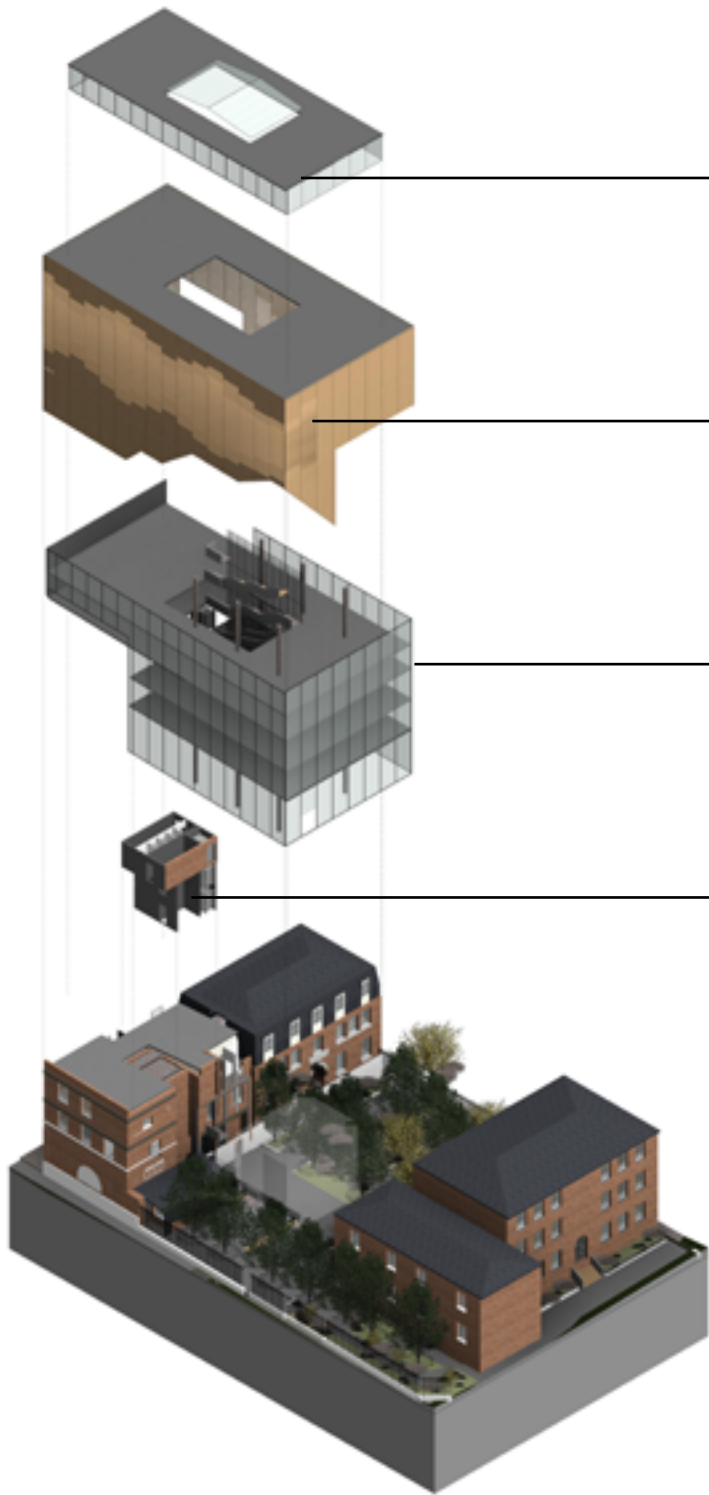

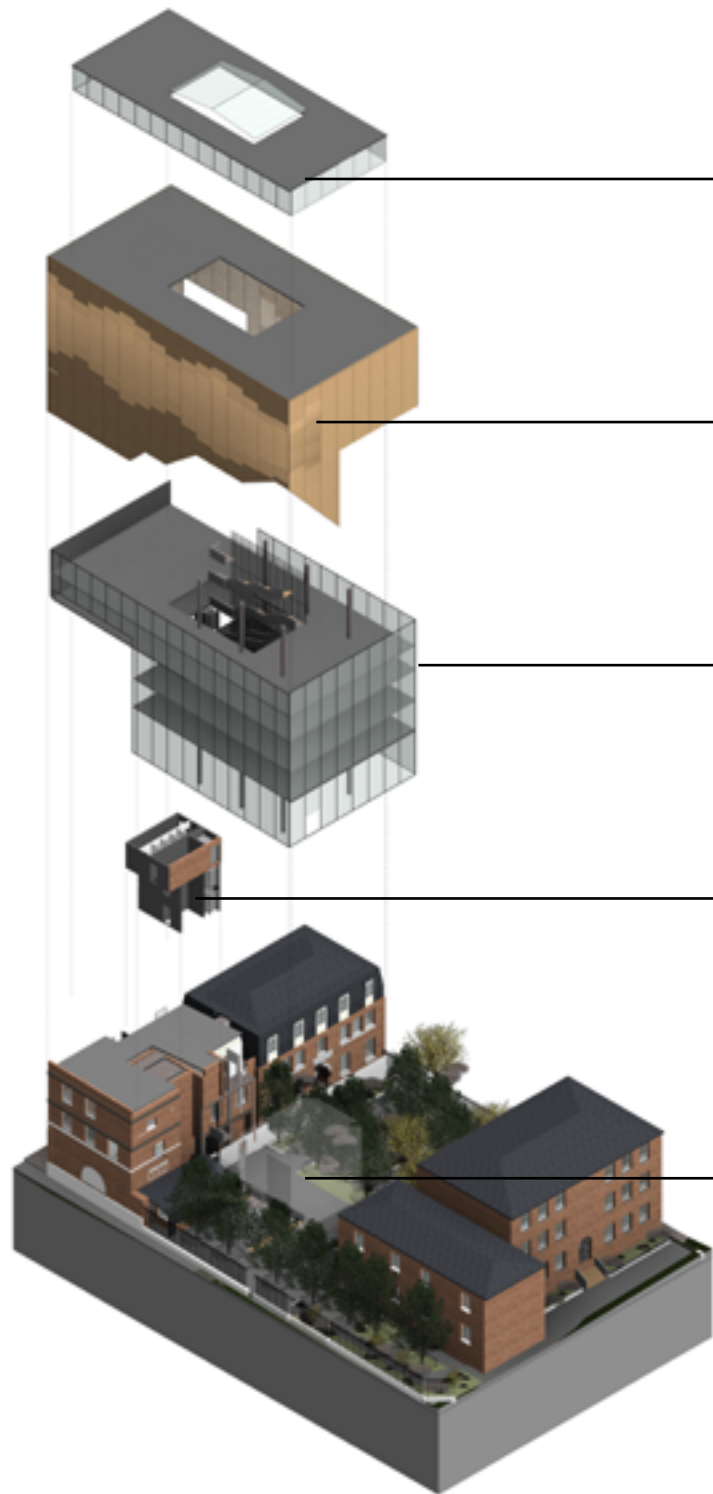

Coroamento em vidro

Casca em ripas de madeira horizontal com dimensão e coloração aproximada ao do tijolo

Andares e esquadrias em pele de vidro

Núcleo de serviços sobreposto ao núcleo existente

Pavilhão de Source à demolir e tres arvores arvores a serem teriradas



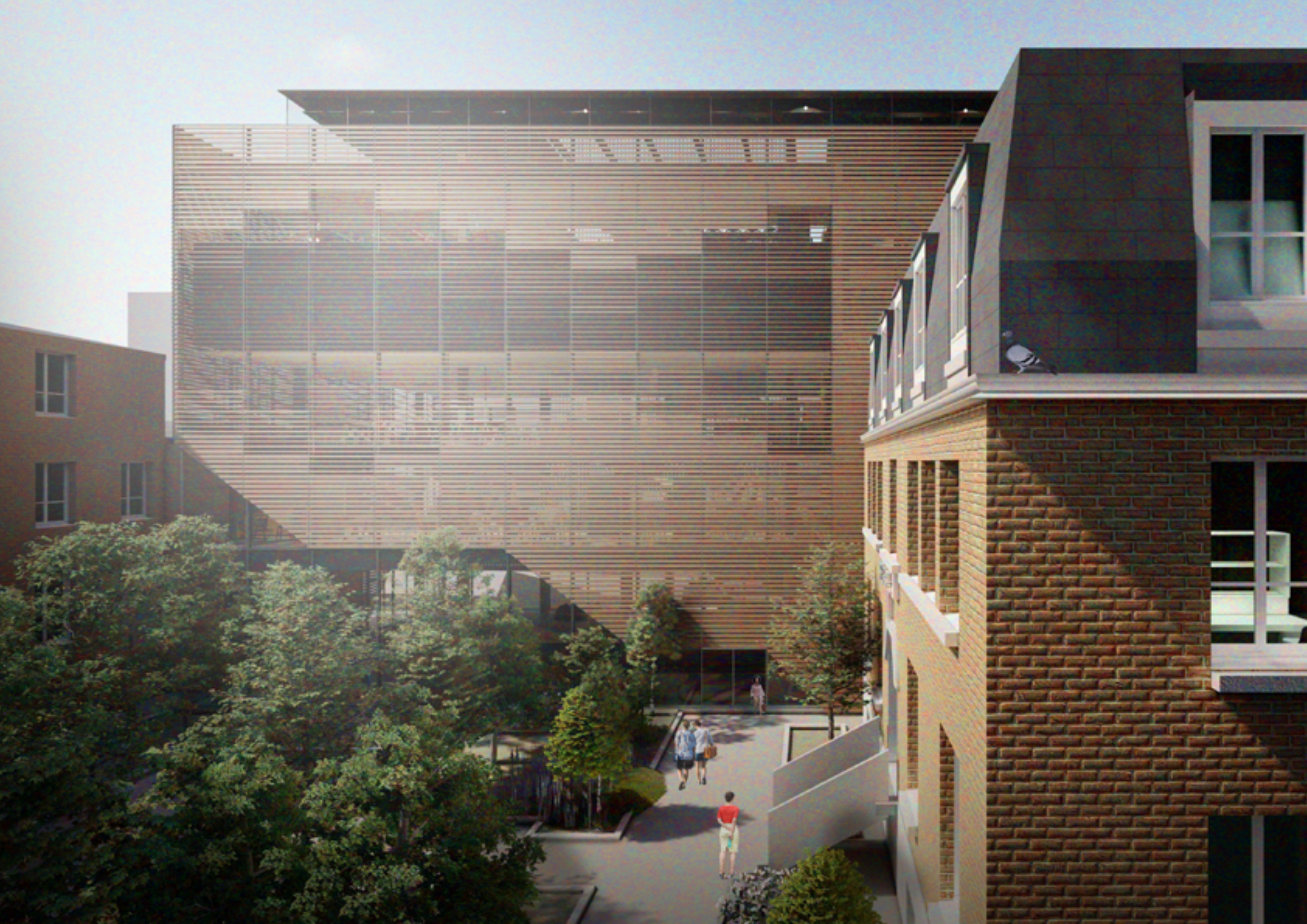

Subsolo

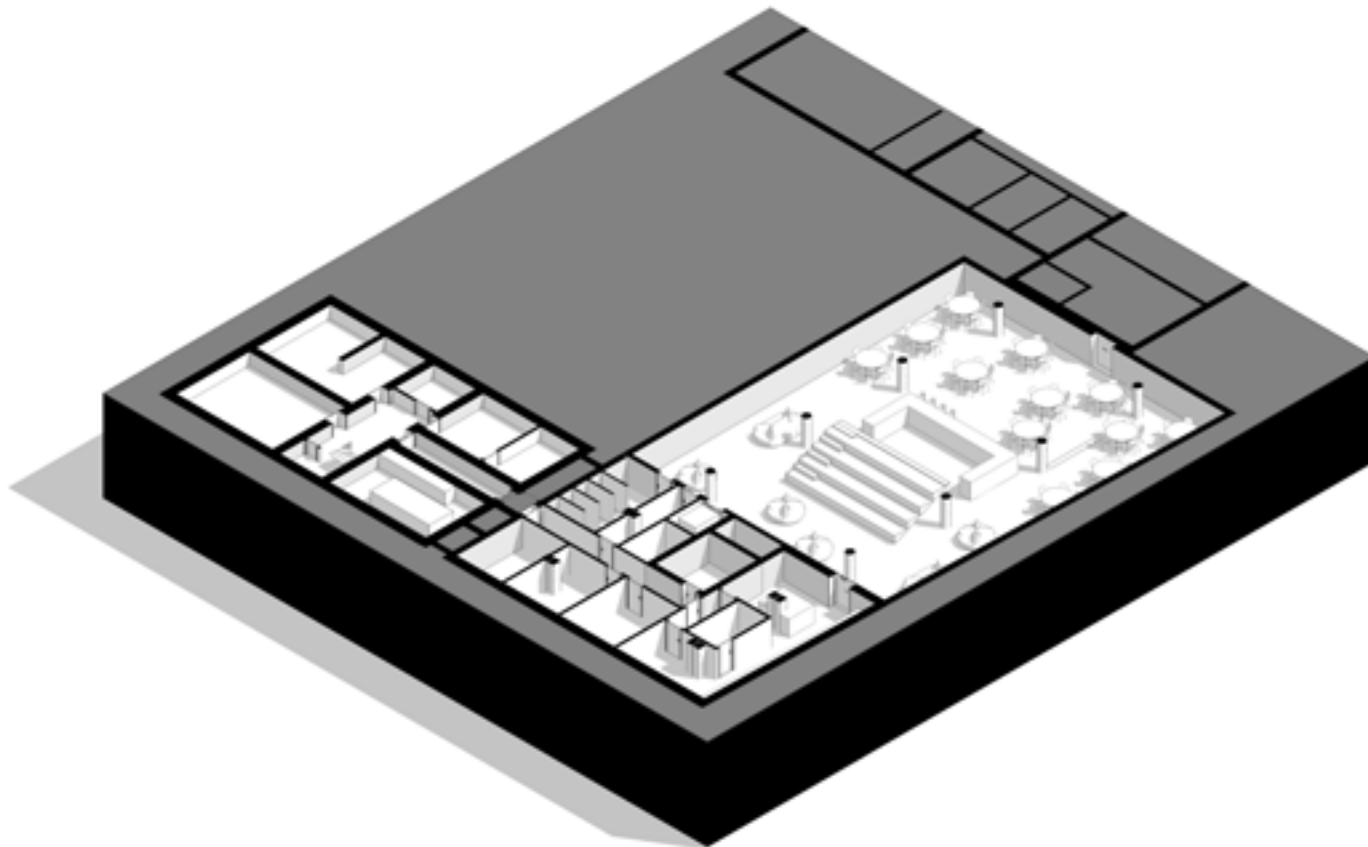

Subsolo

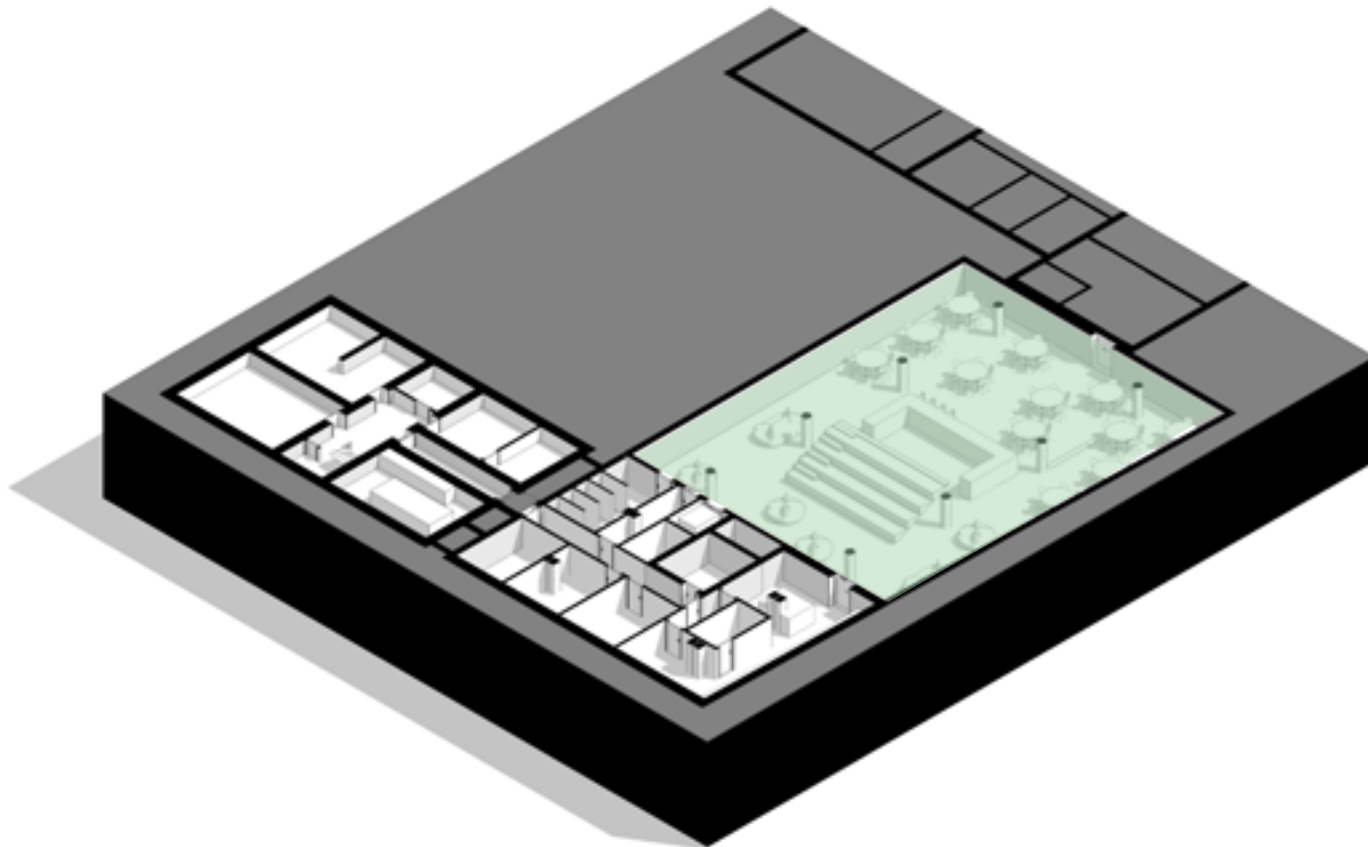

Subsolo

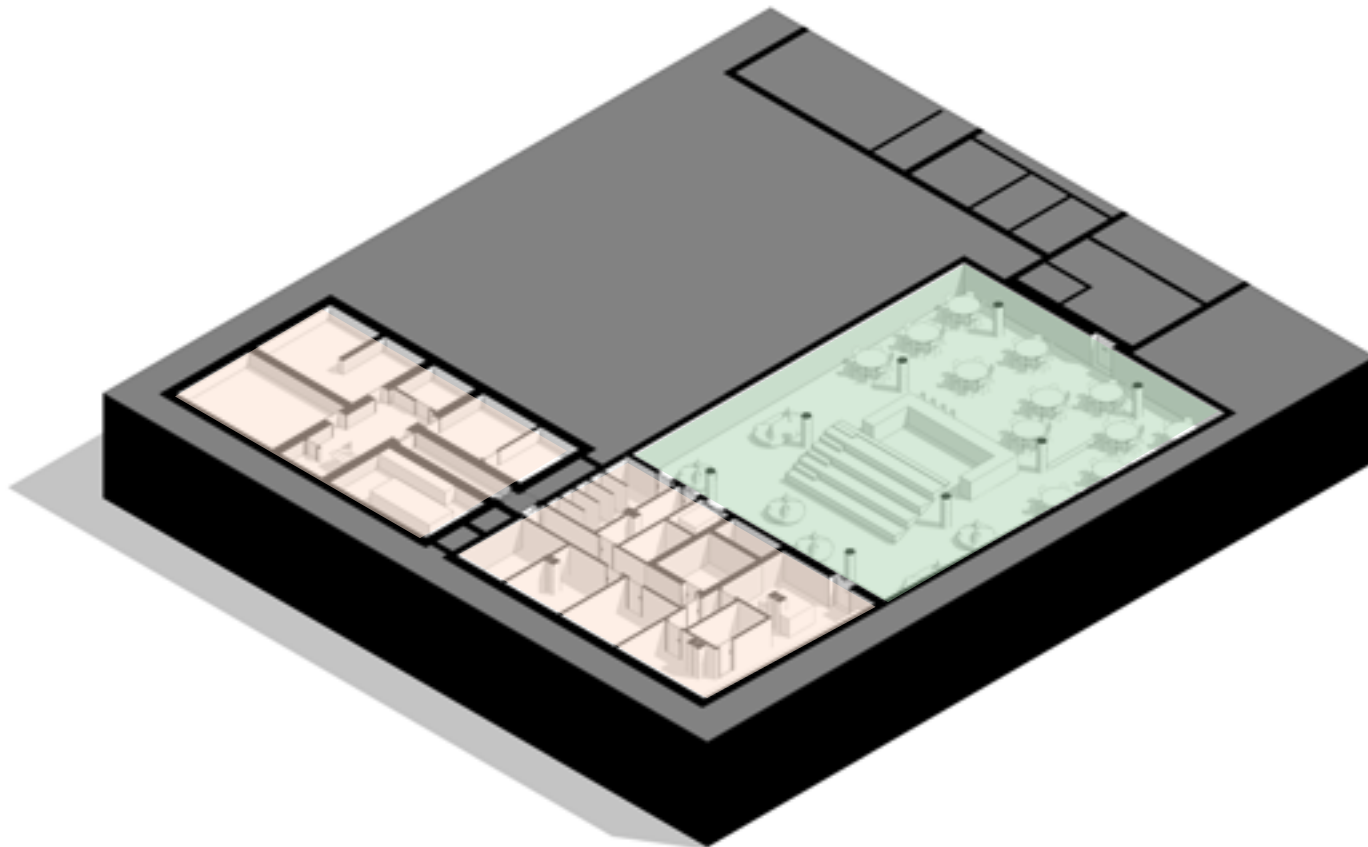

Térreo

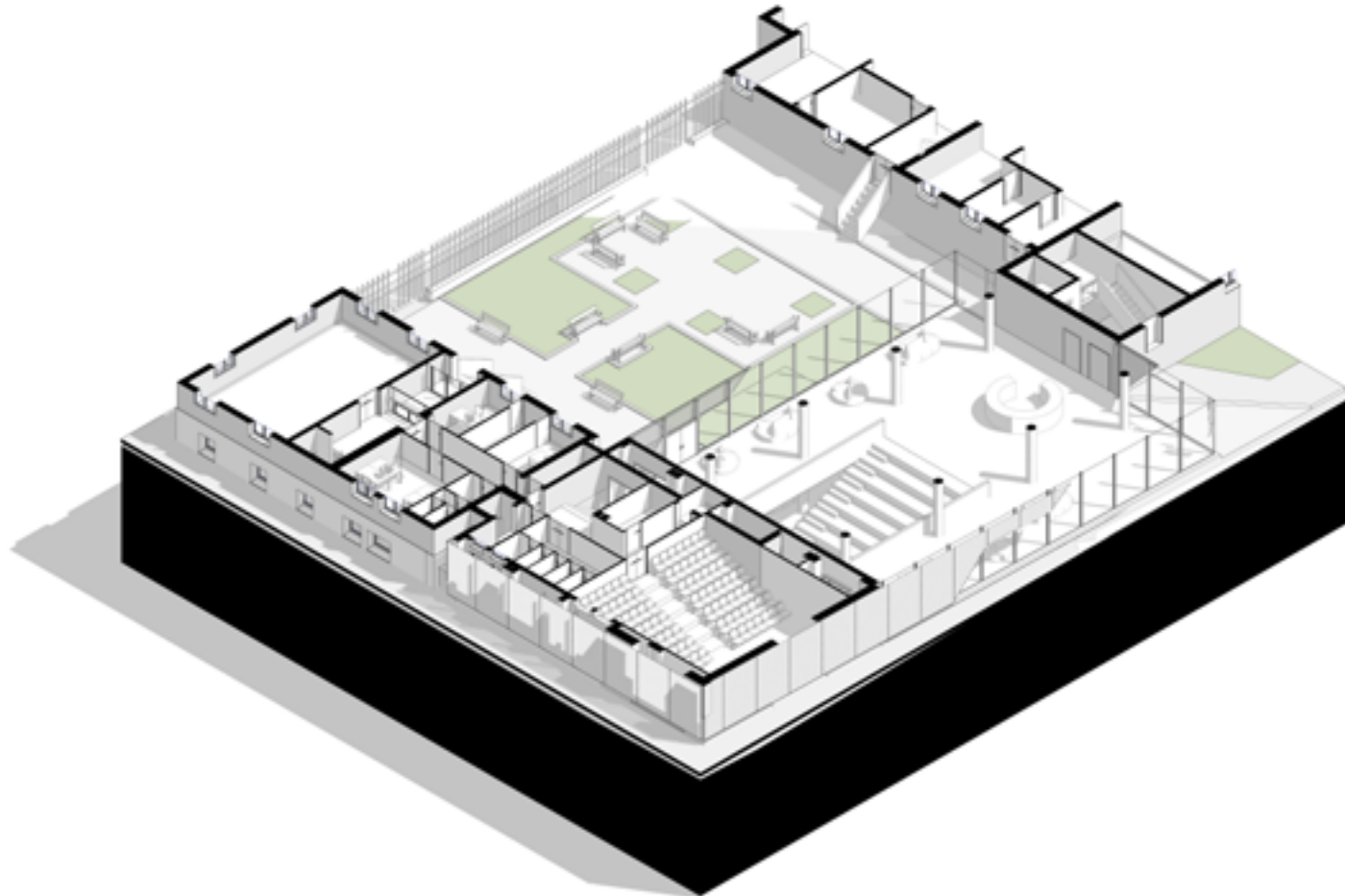

Térreo

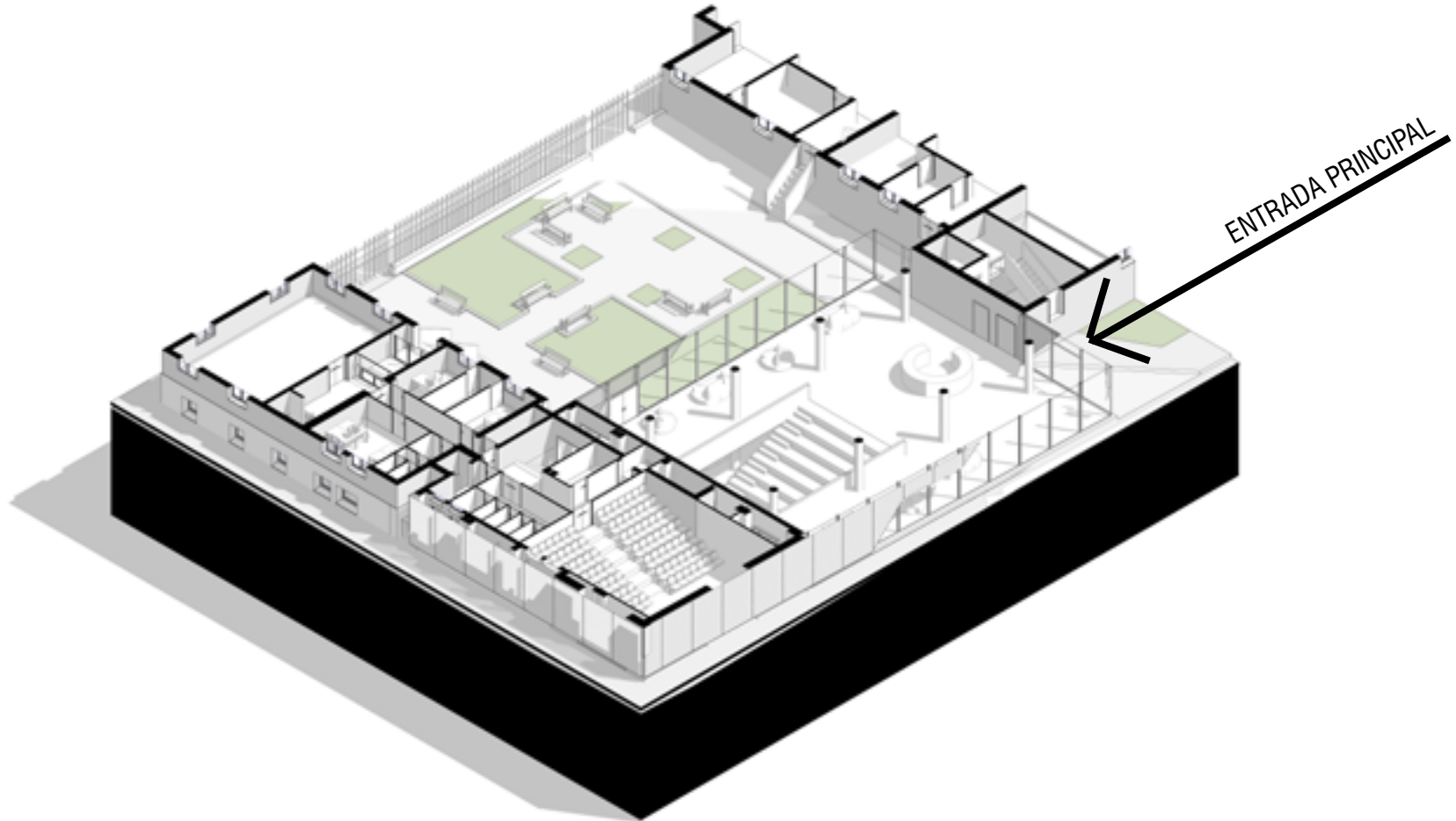

Térreo

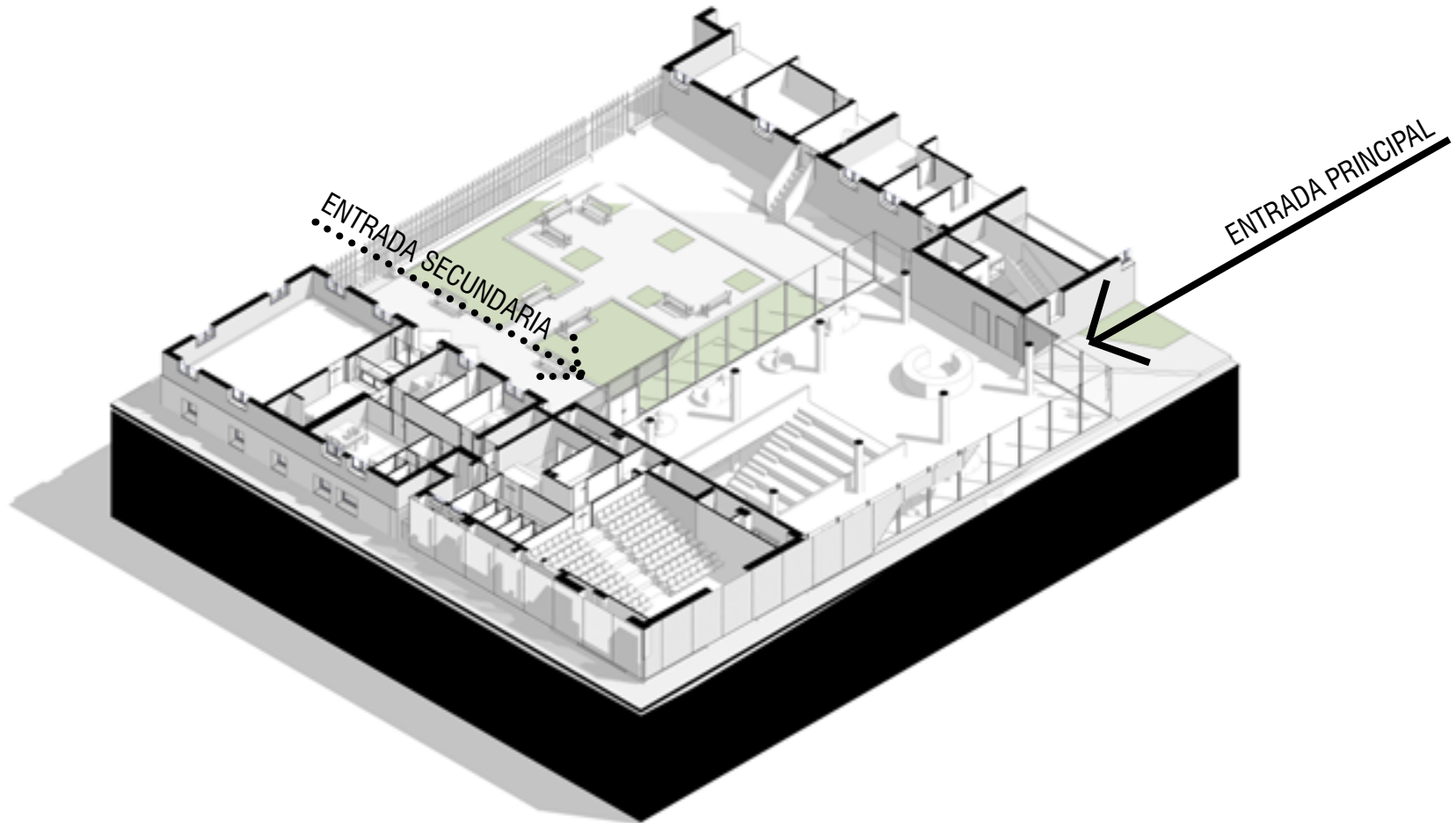

Térreo

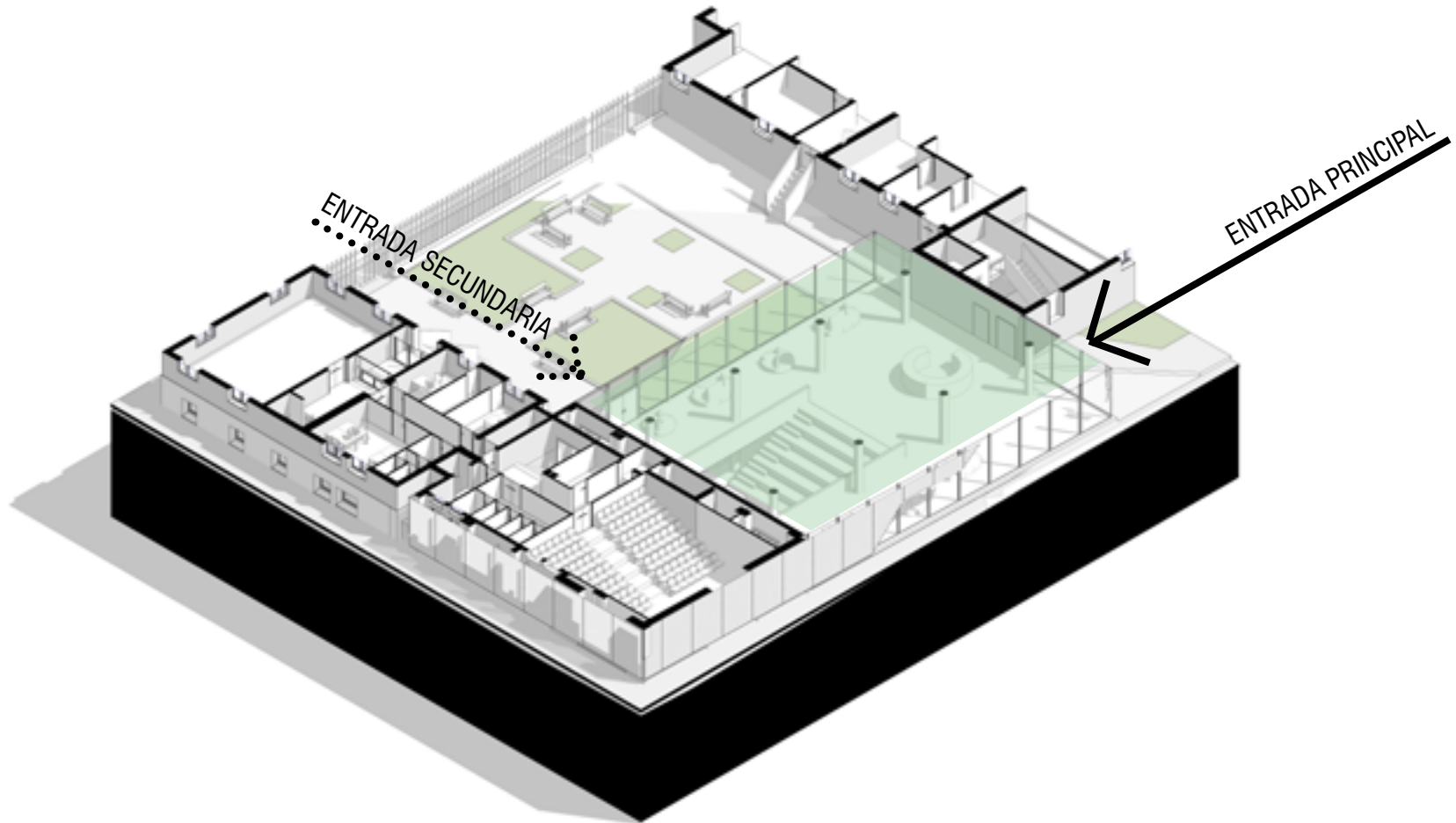



Térreo

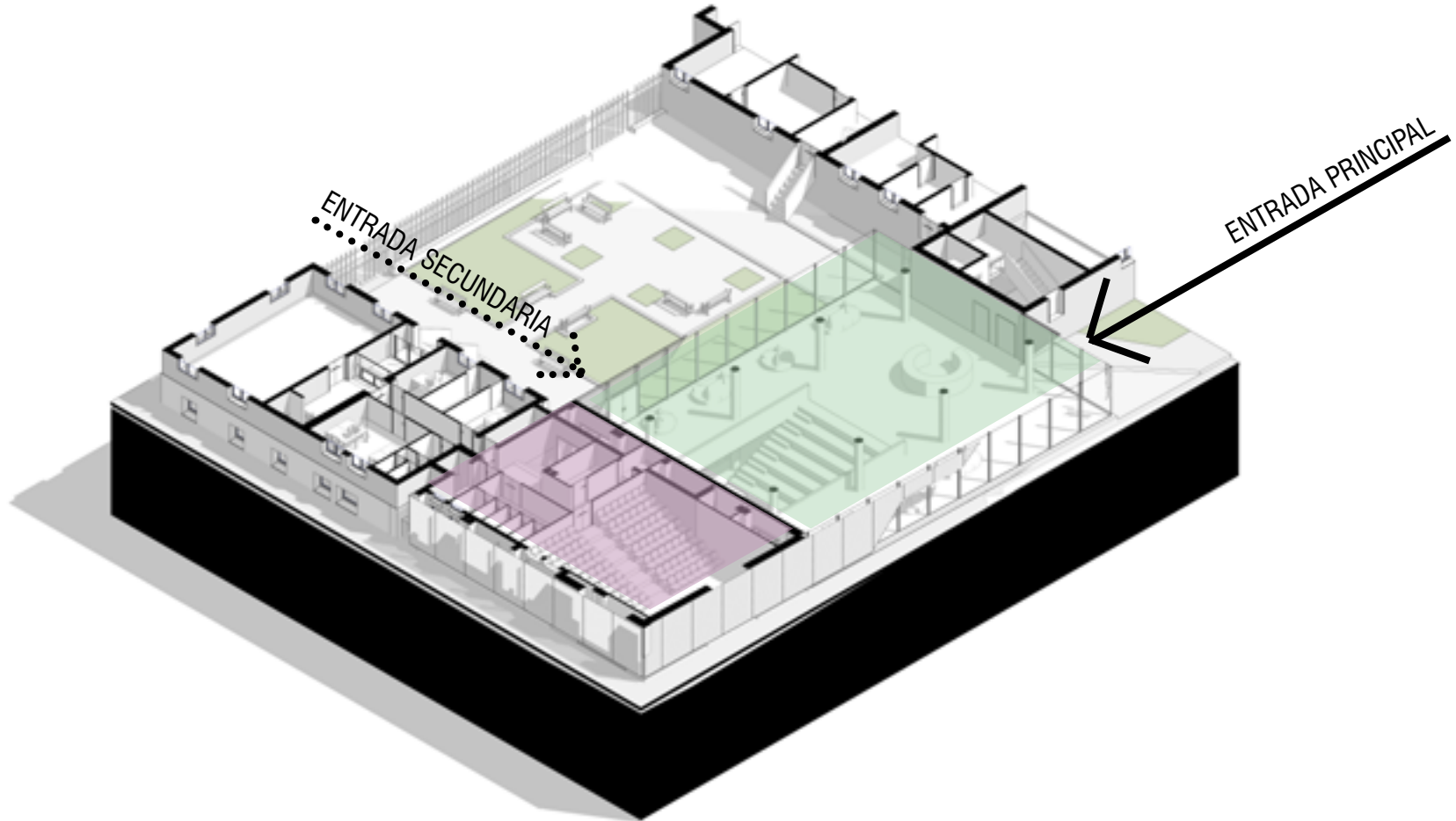

Térreo

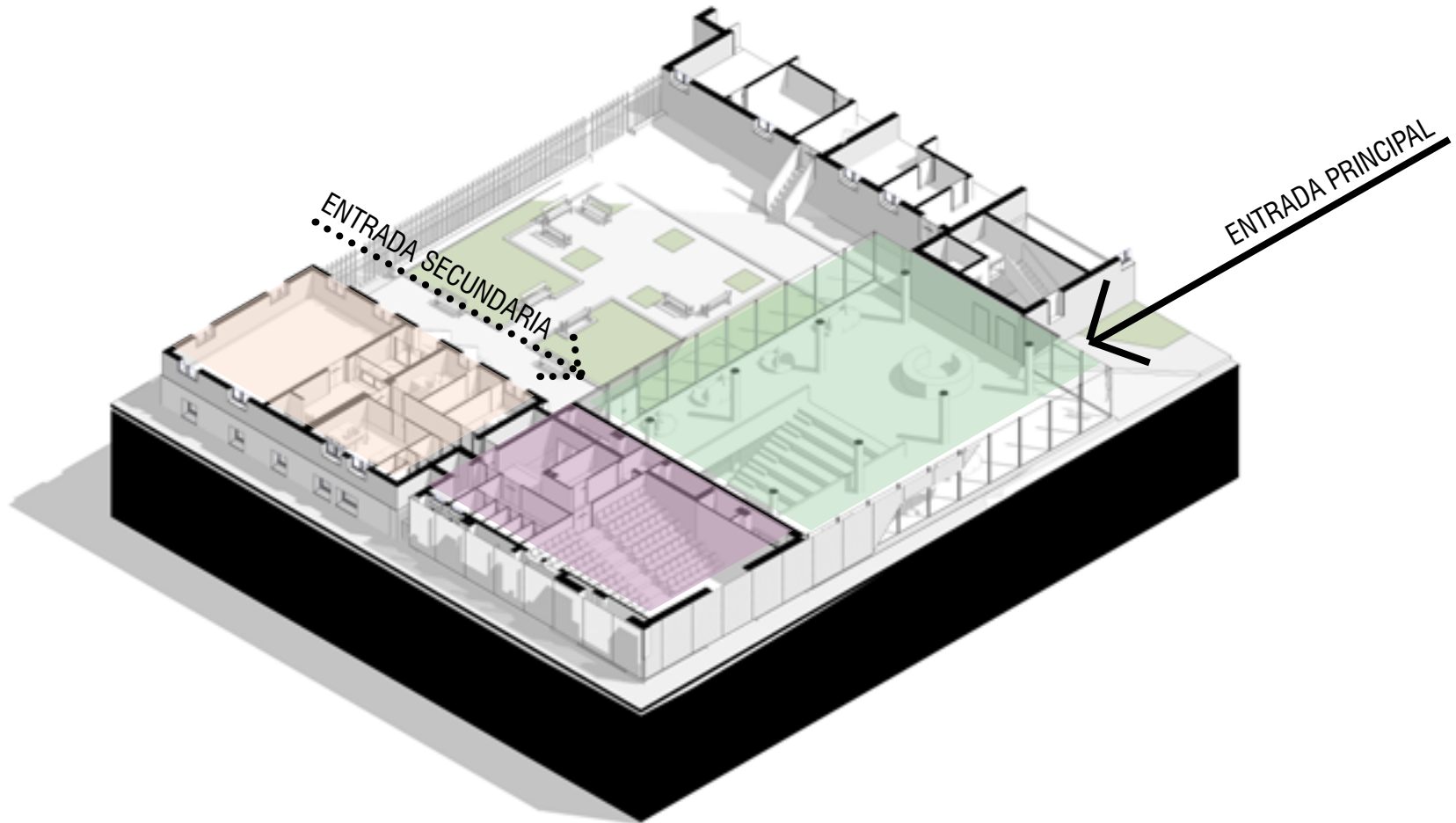

2 pavto

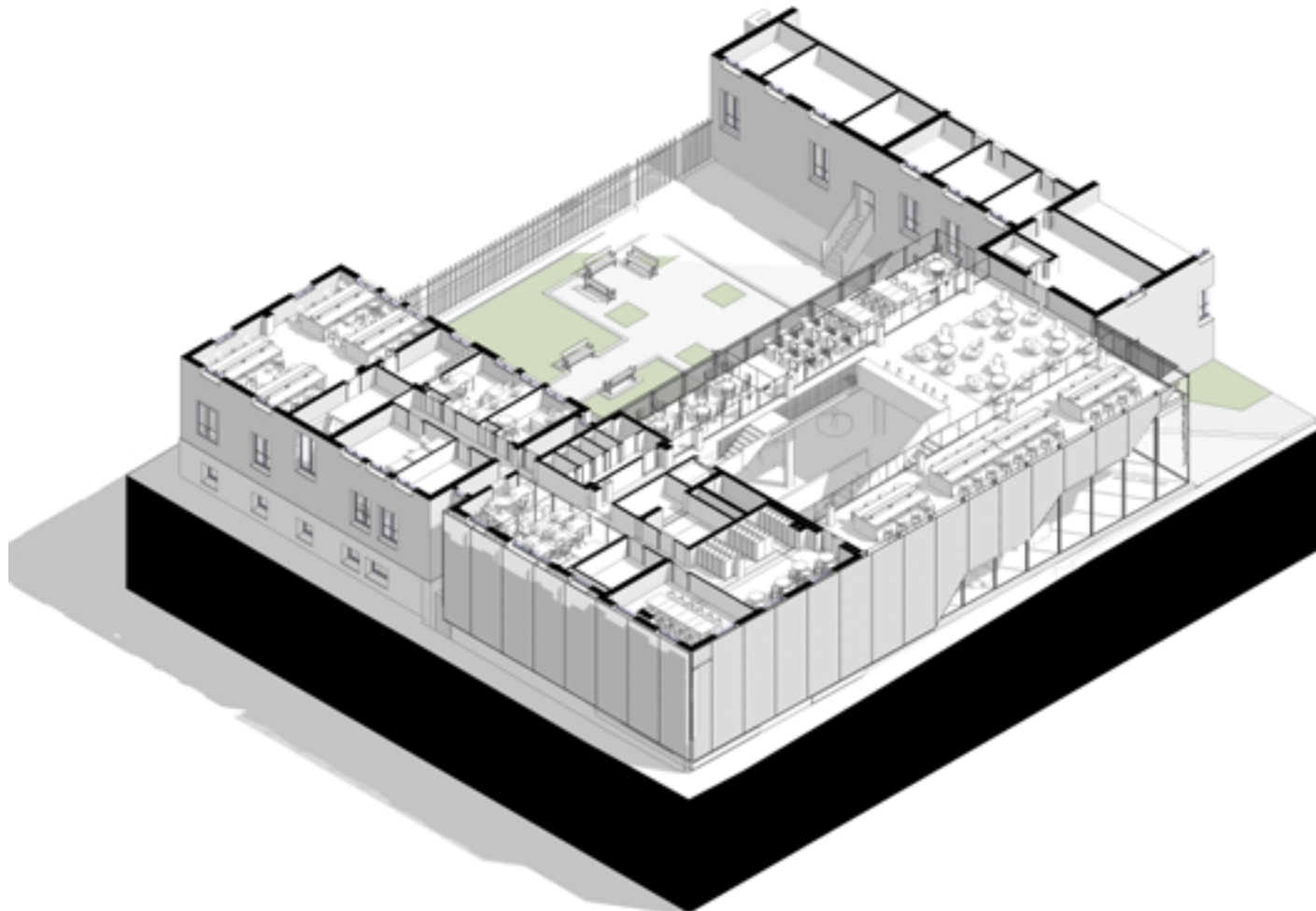

2 pavto

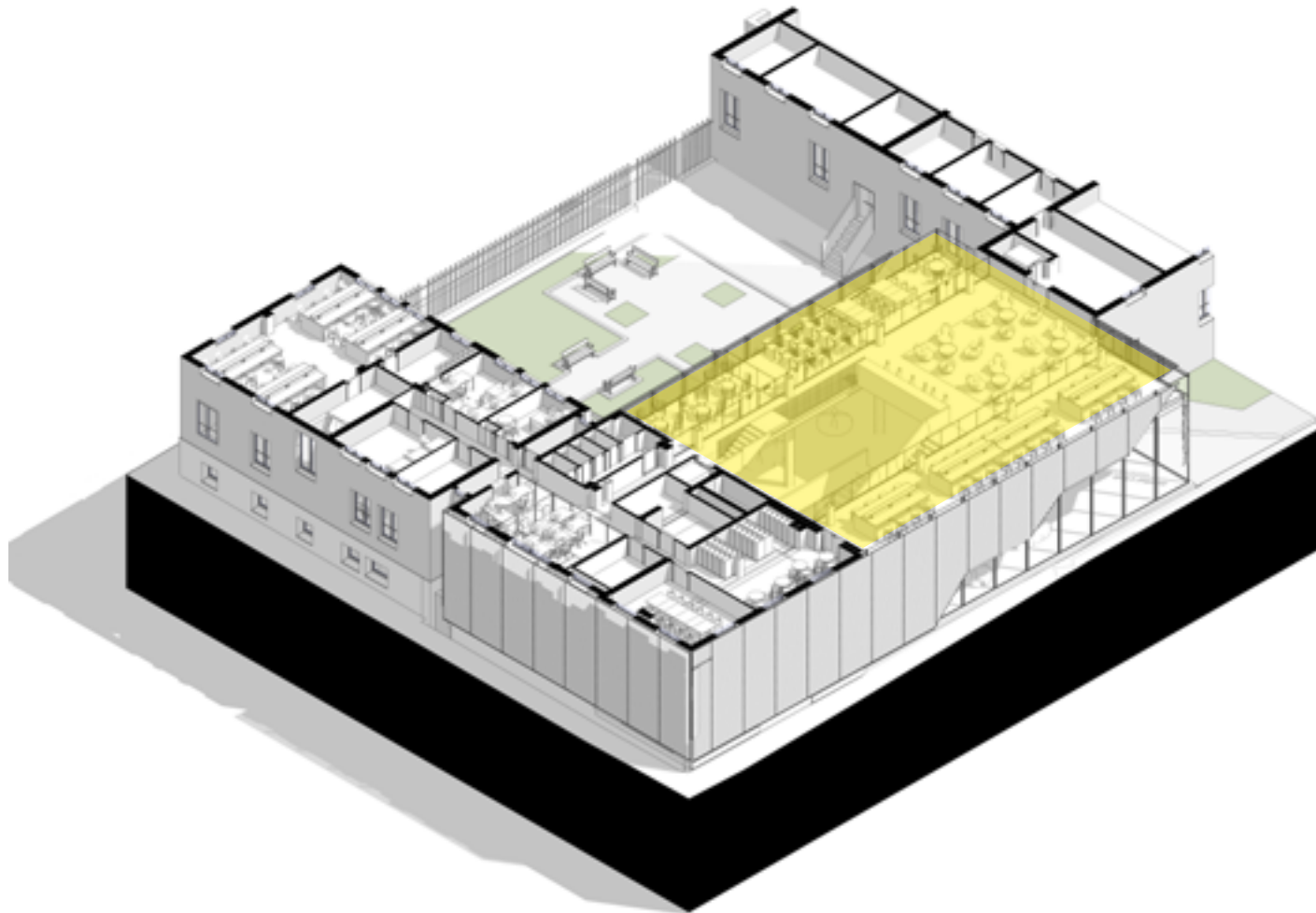

2 pavto

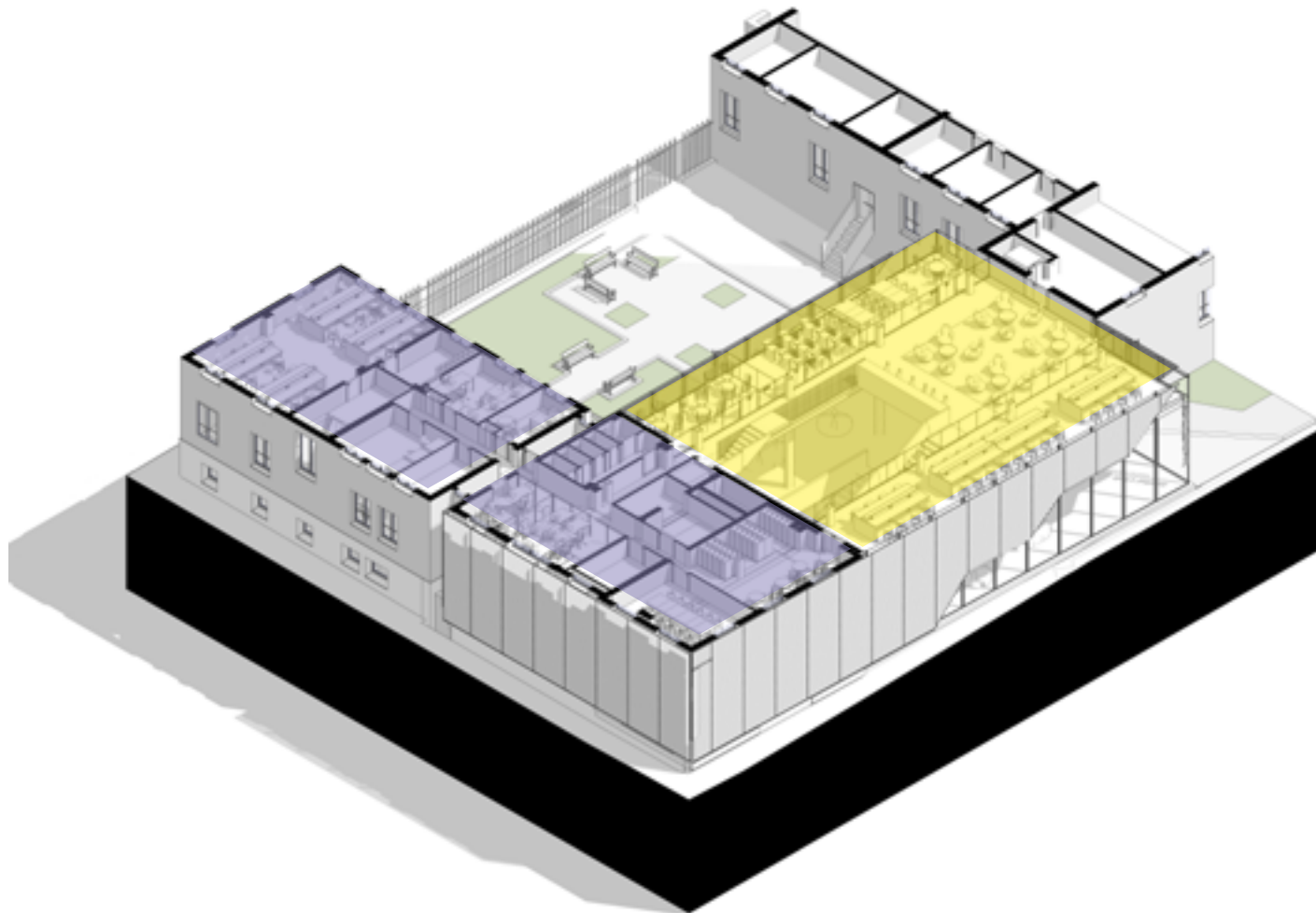

3 pavto

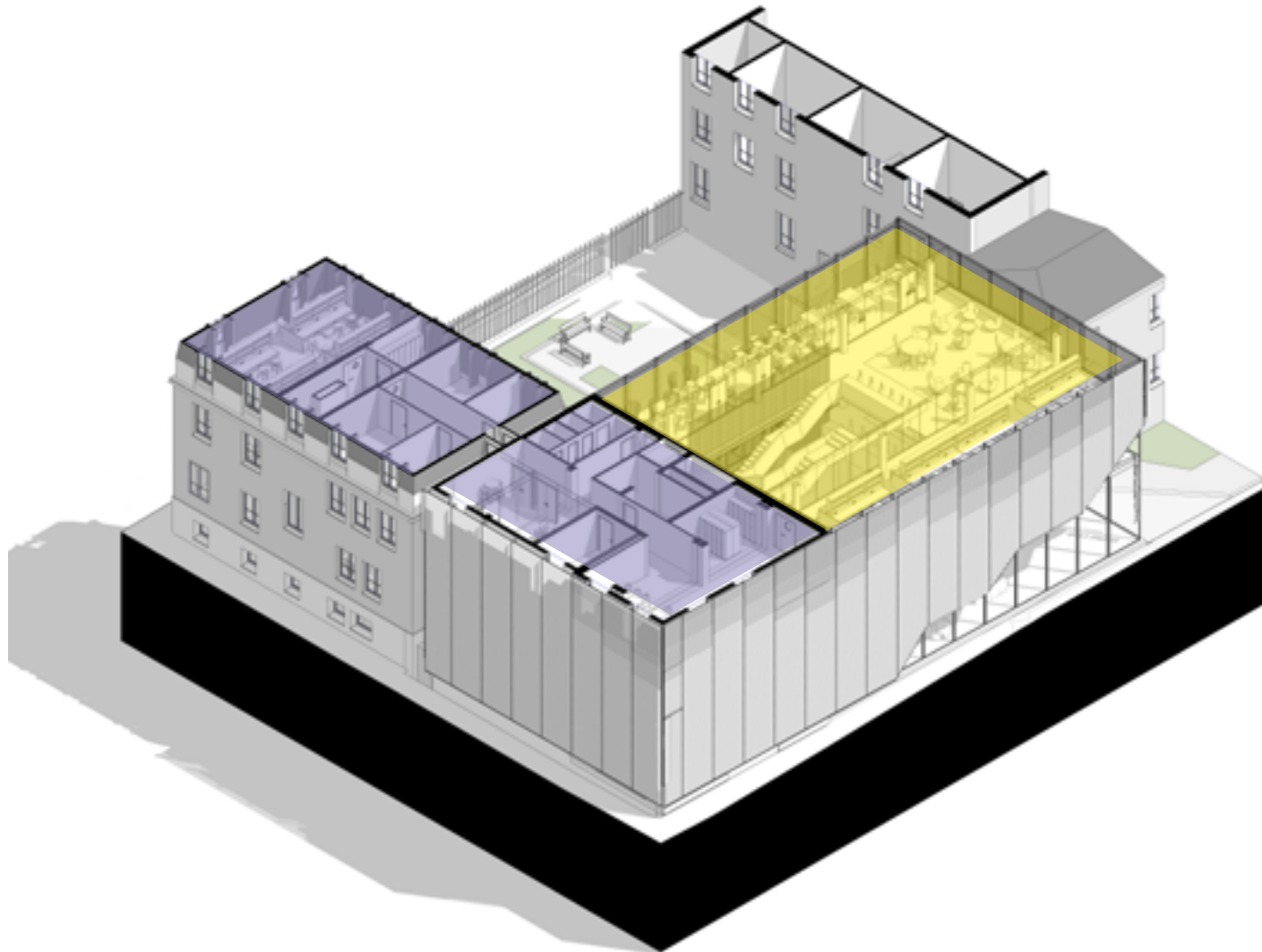

4 pavto

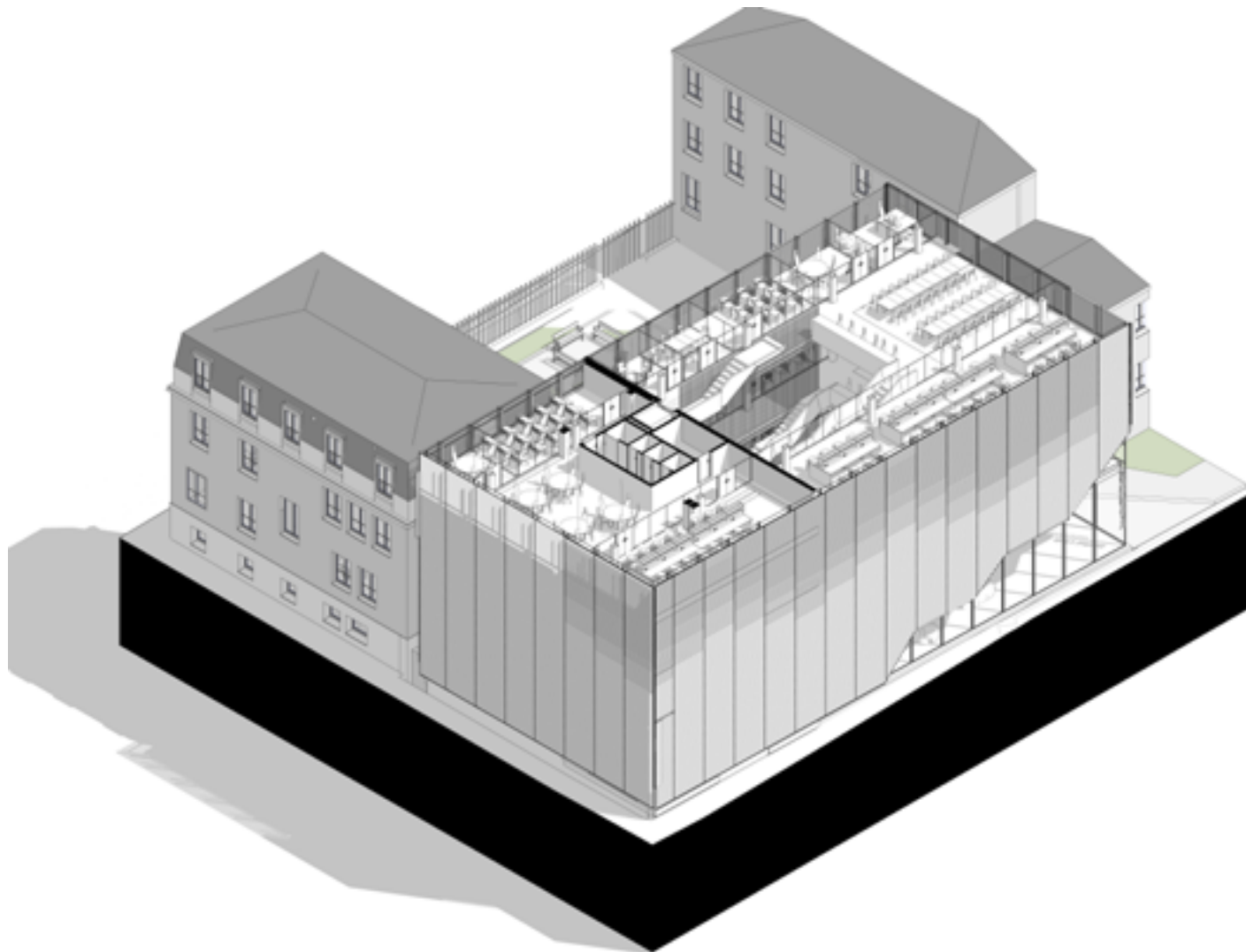

4 pavto

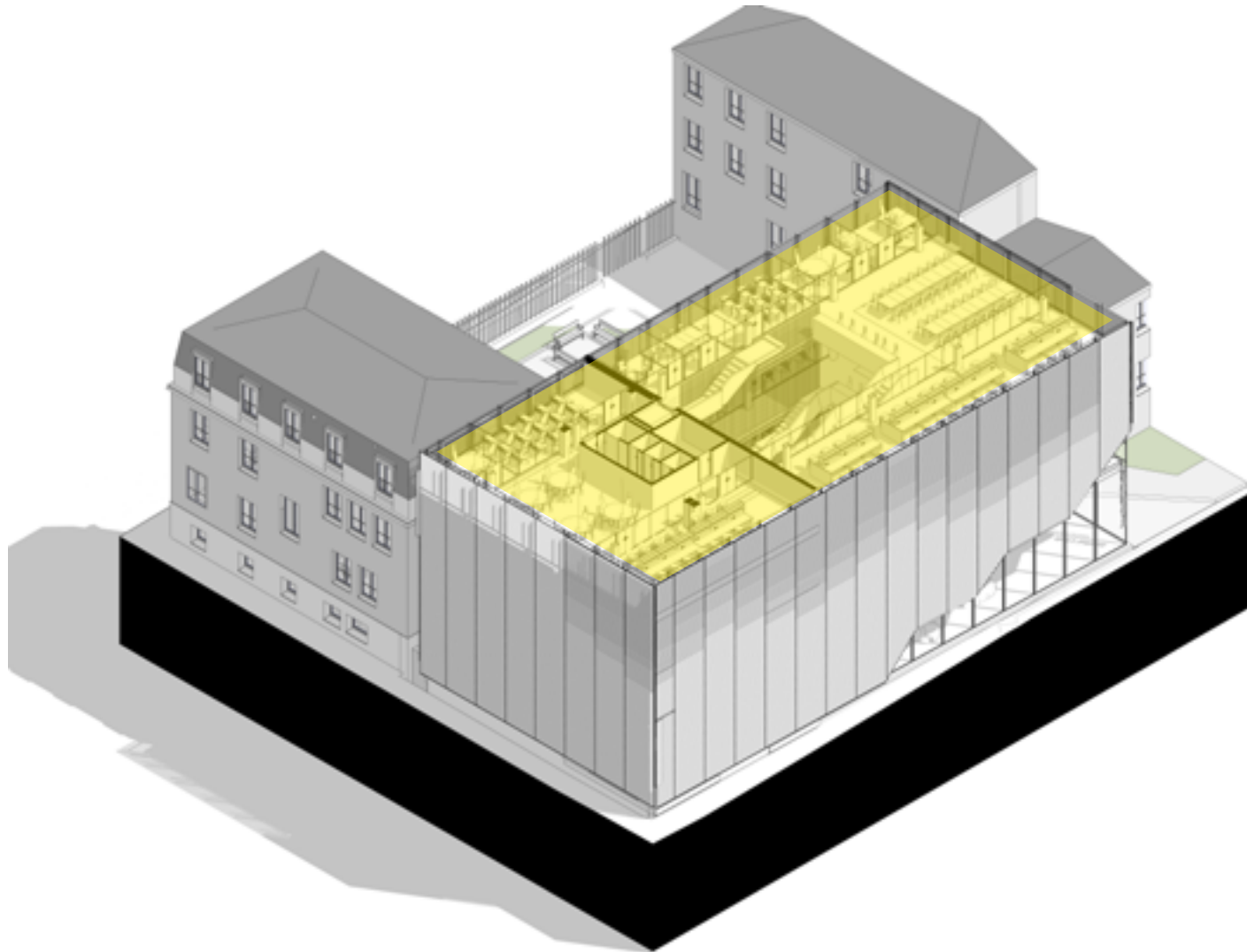



5 pavto

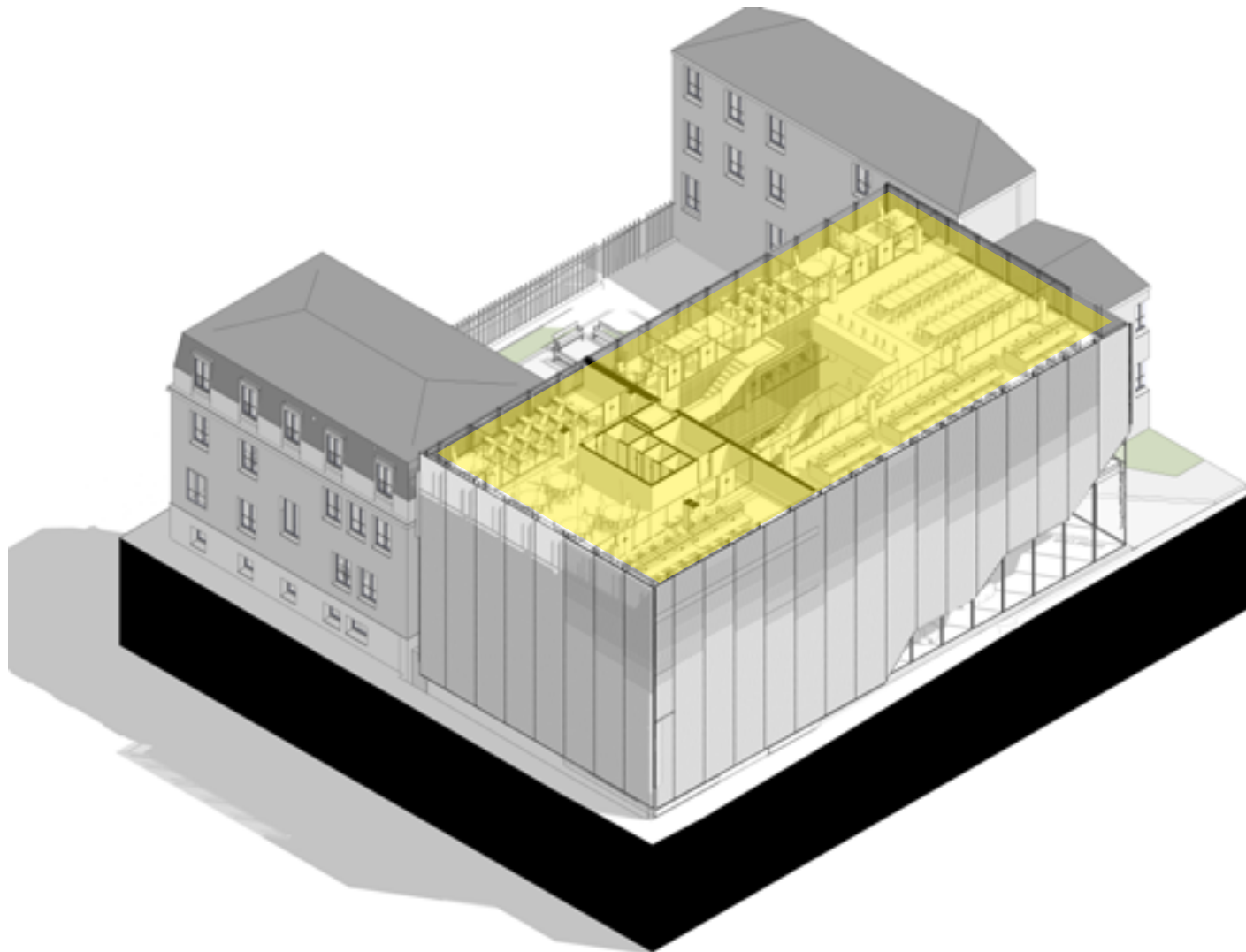

6 pavto

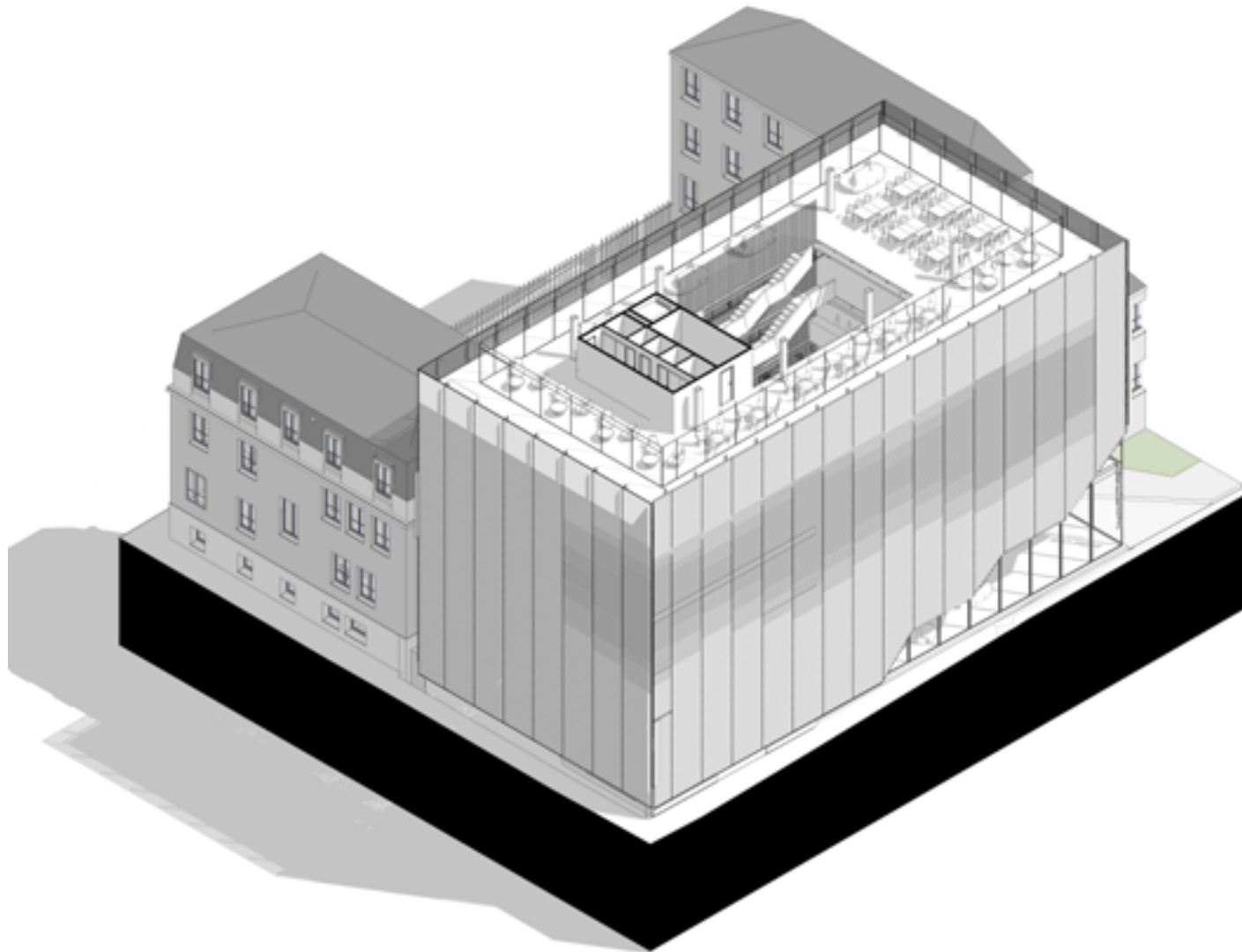

6 pavto

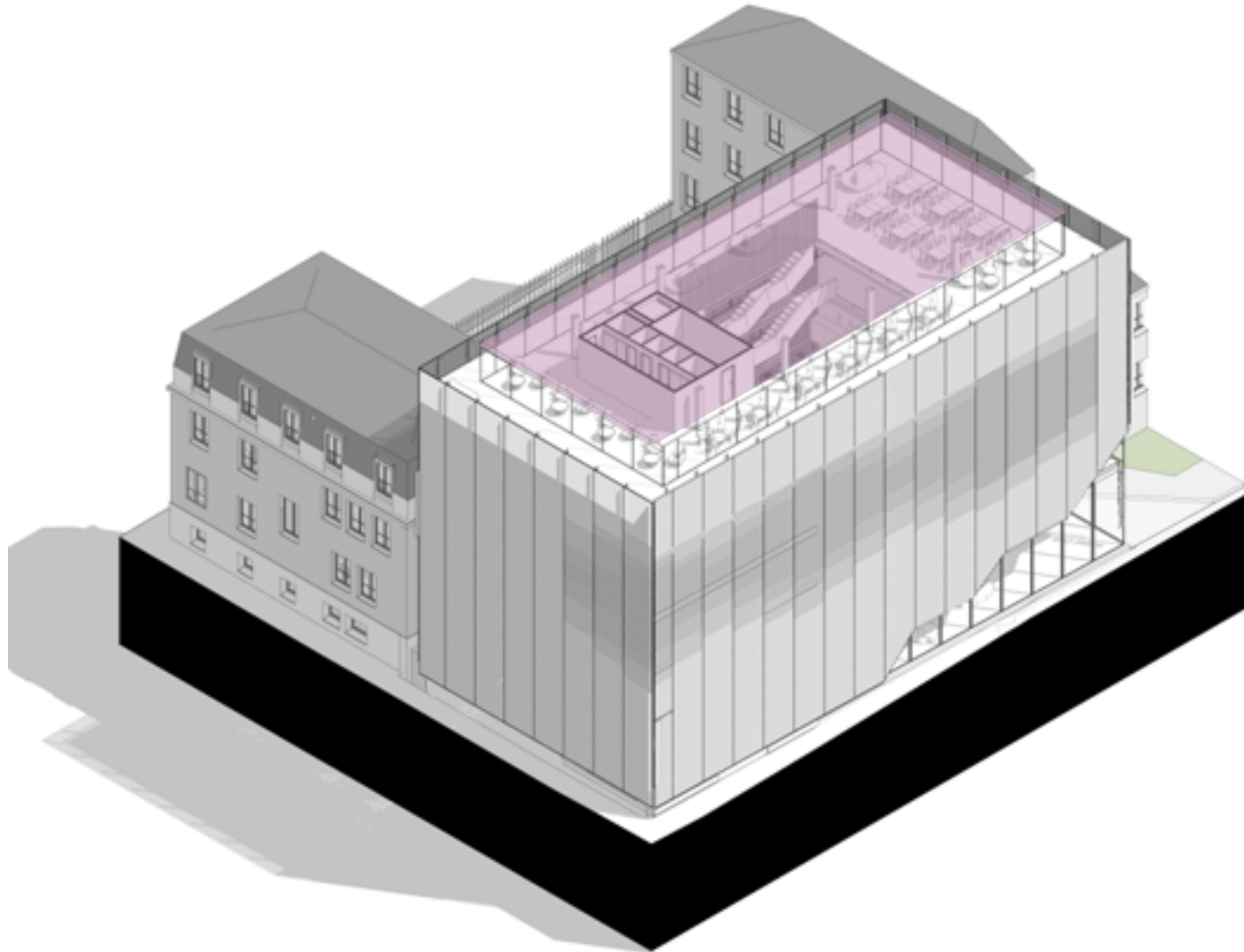

Cobertura

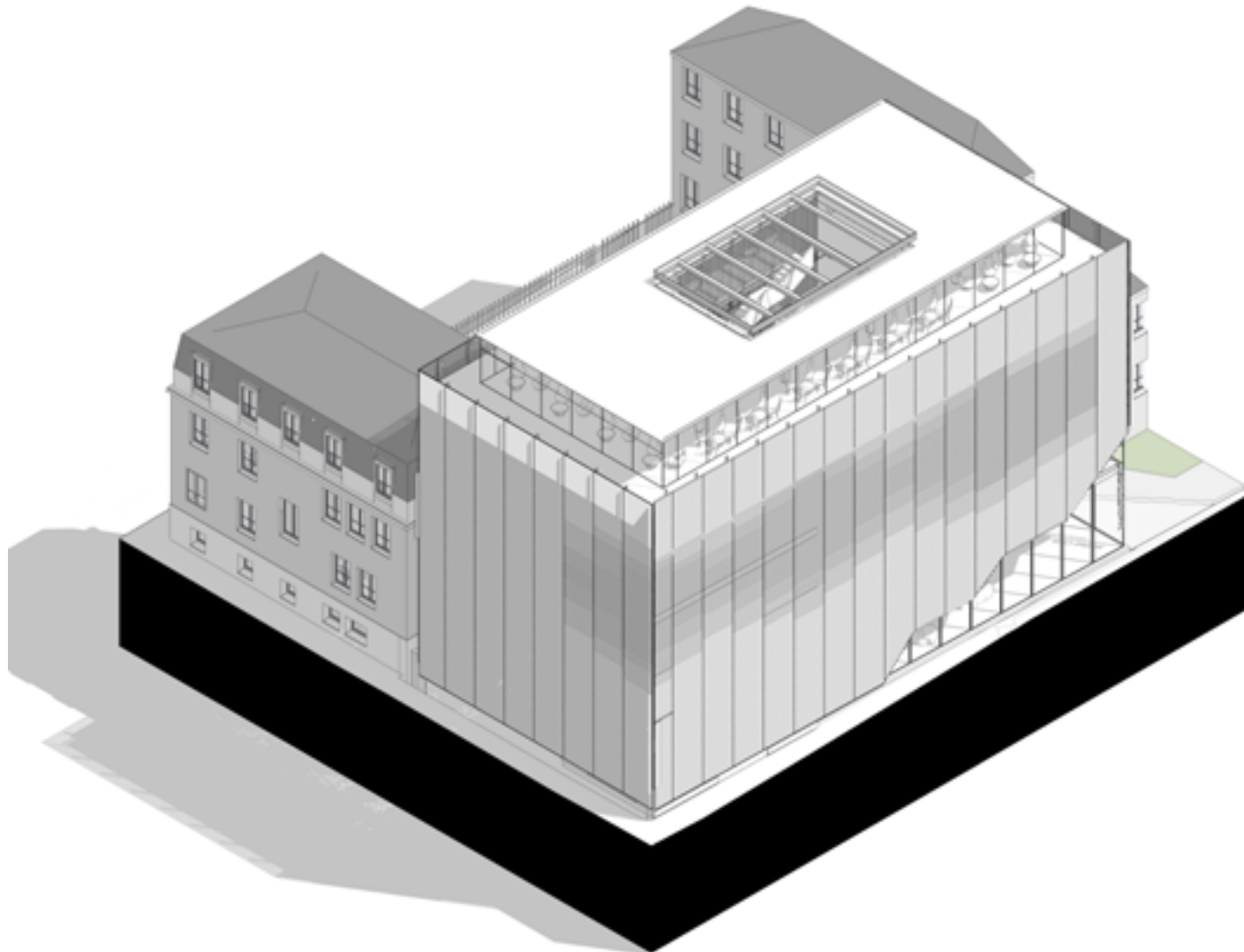

Estrutura mista:

base e fundações de **concreto**

**moldado in loco**

e novos elementos

estruturais **em aço**

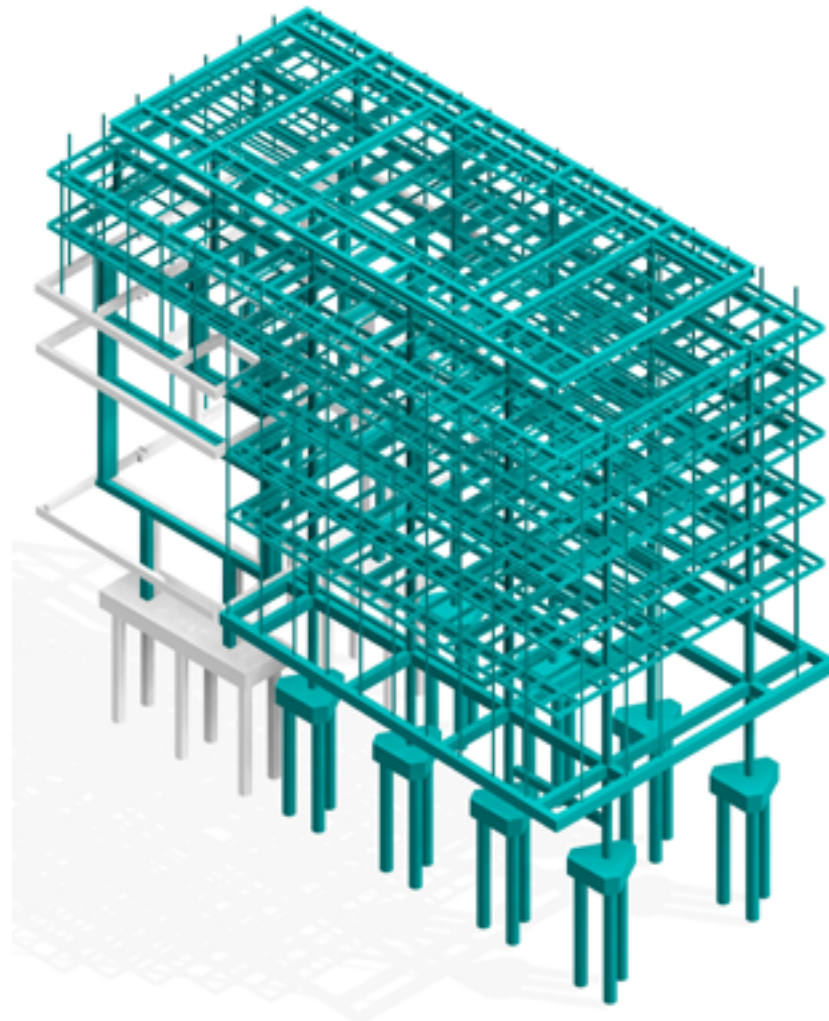

Estrutura Existente e Fundacoes

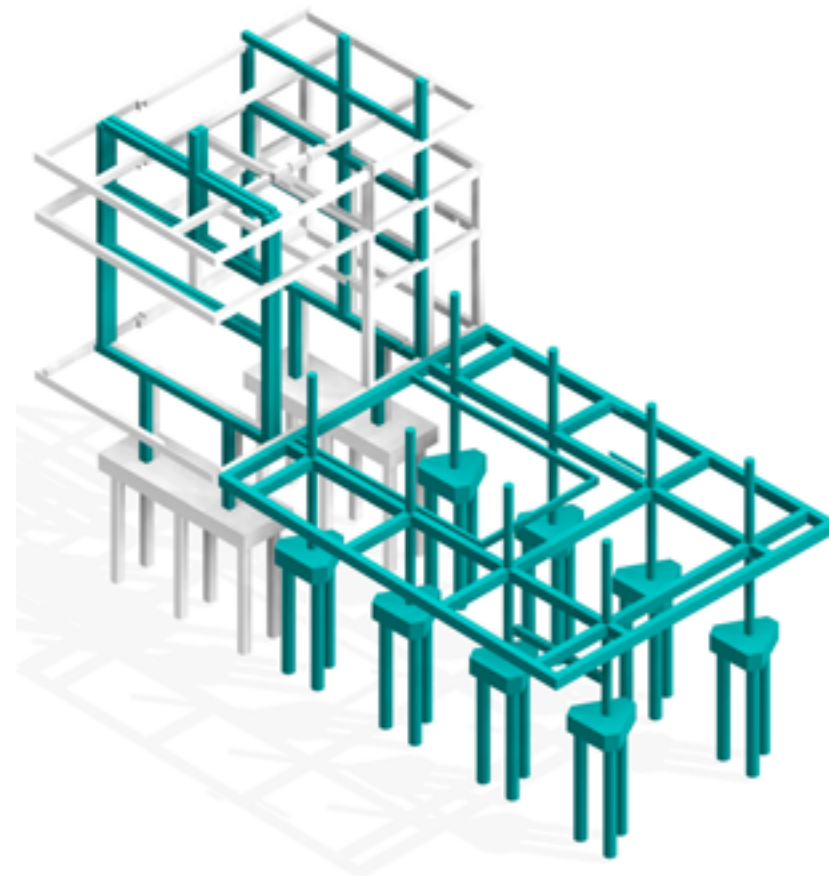

Estrutura 1, 2 e 3 pavimentos

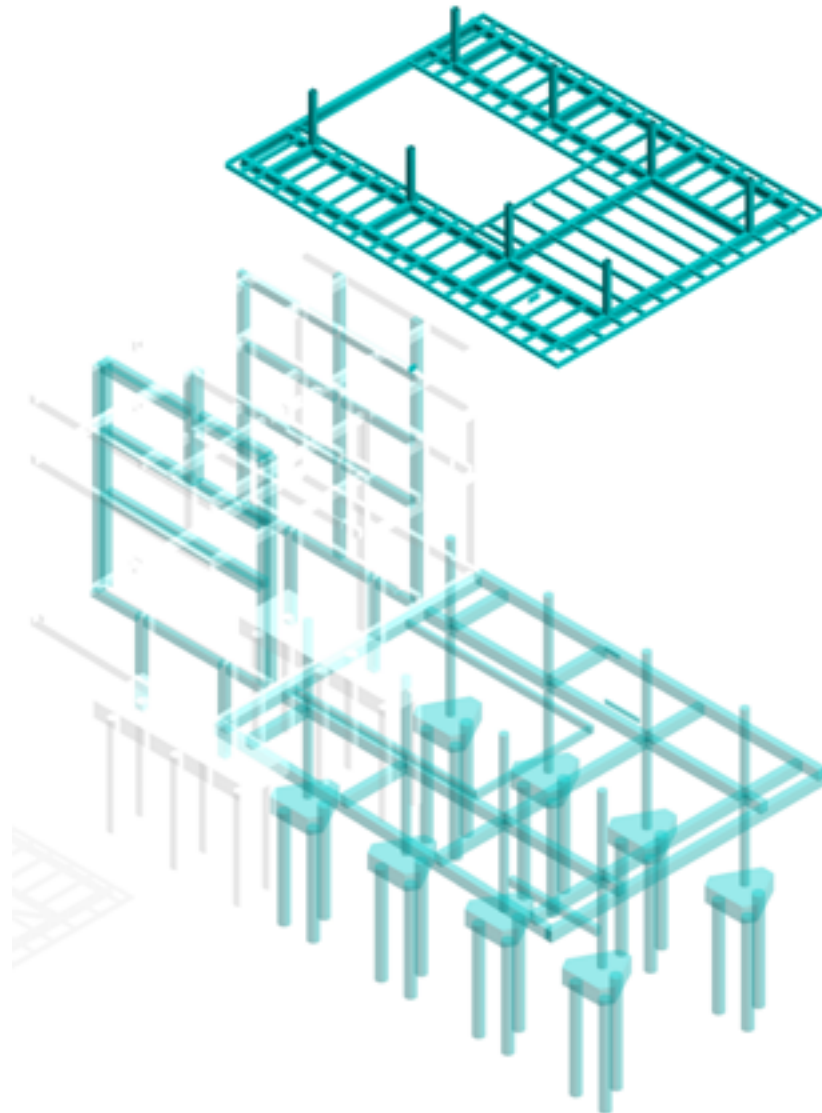

Estrutura 1, 2 e 3 pavimentos

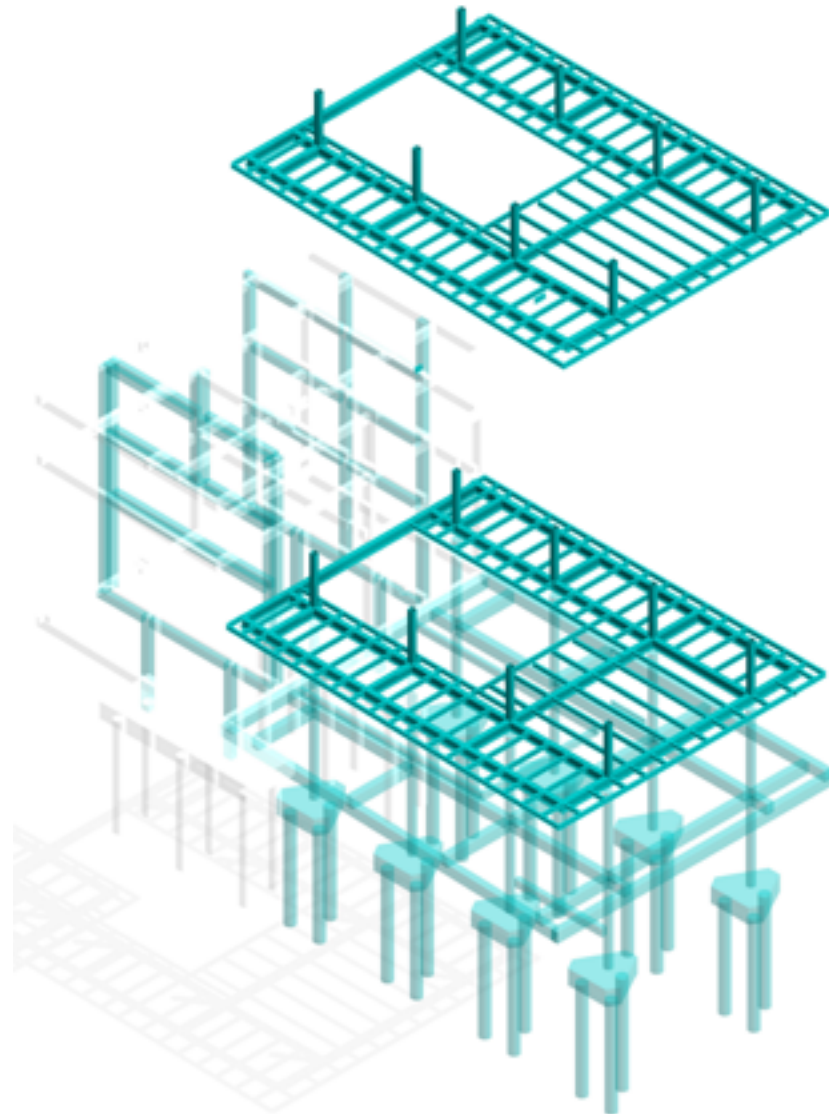



Estrutura 1, 2 e 3 pavimentos

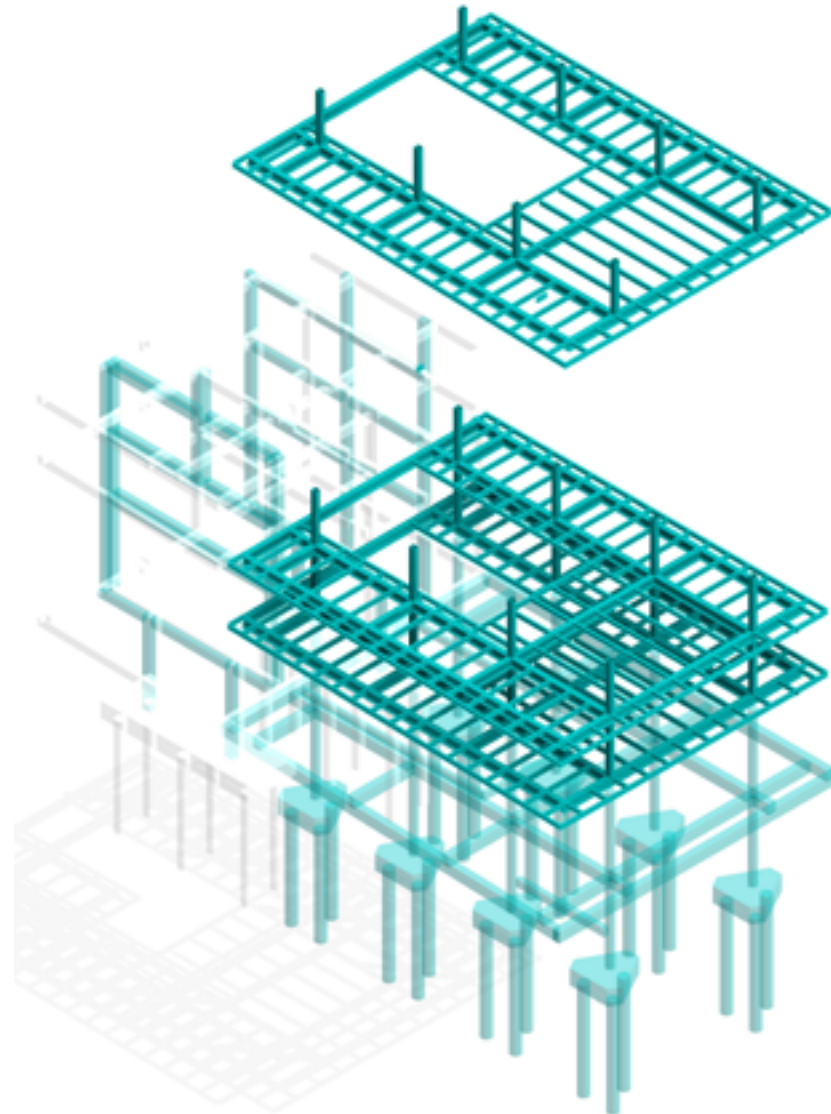

Estrutura 4 e 5 pavimentos

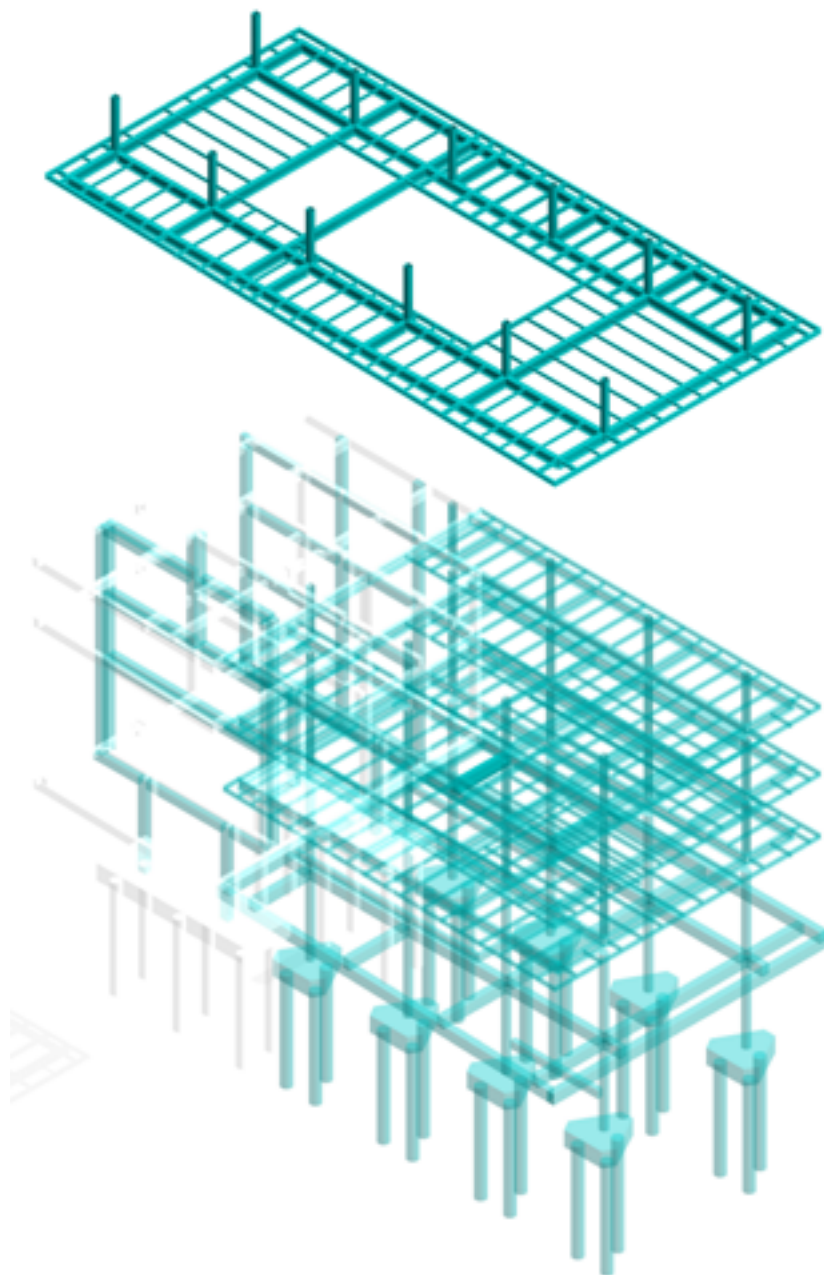

Estrutura 4 e 5 pavimentos

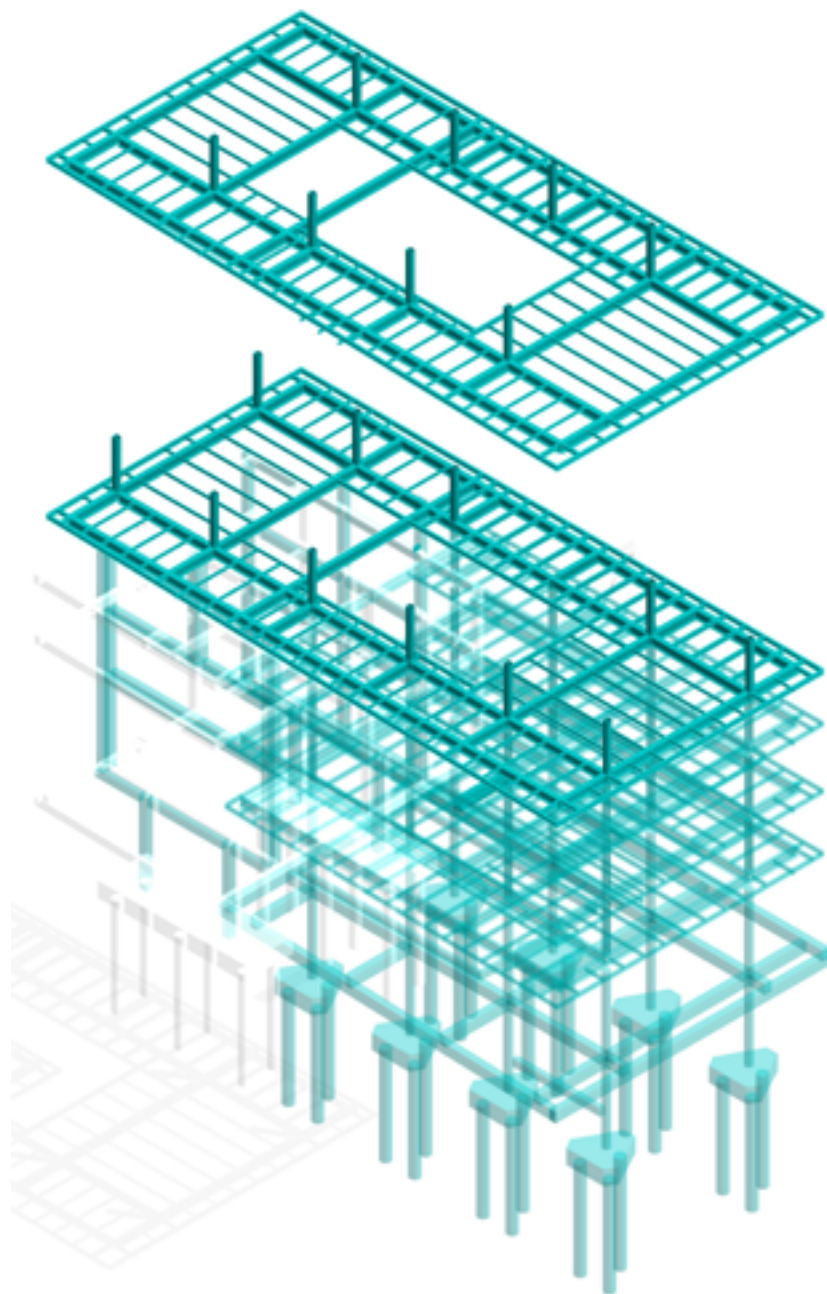

Estrutura cobertura e poço de luz

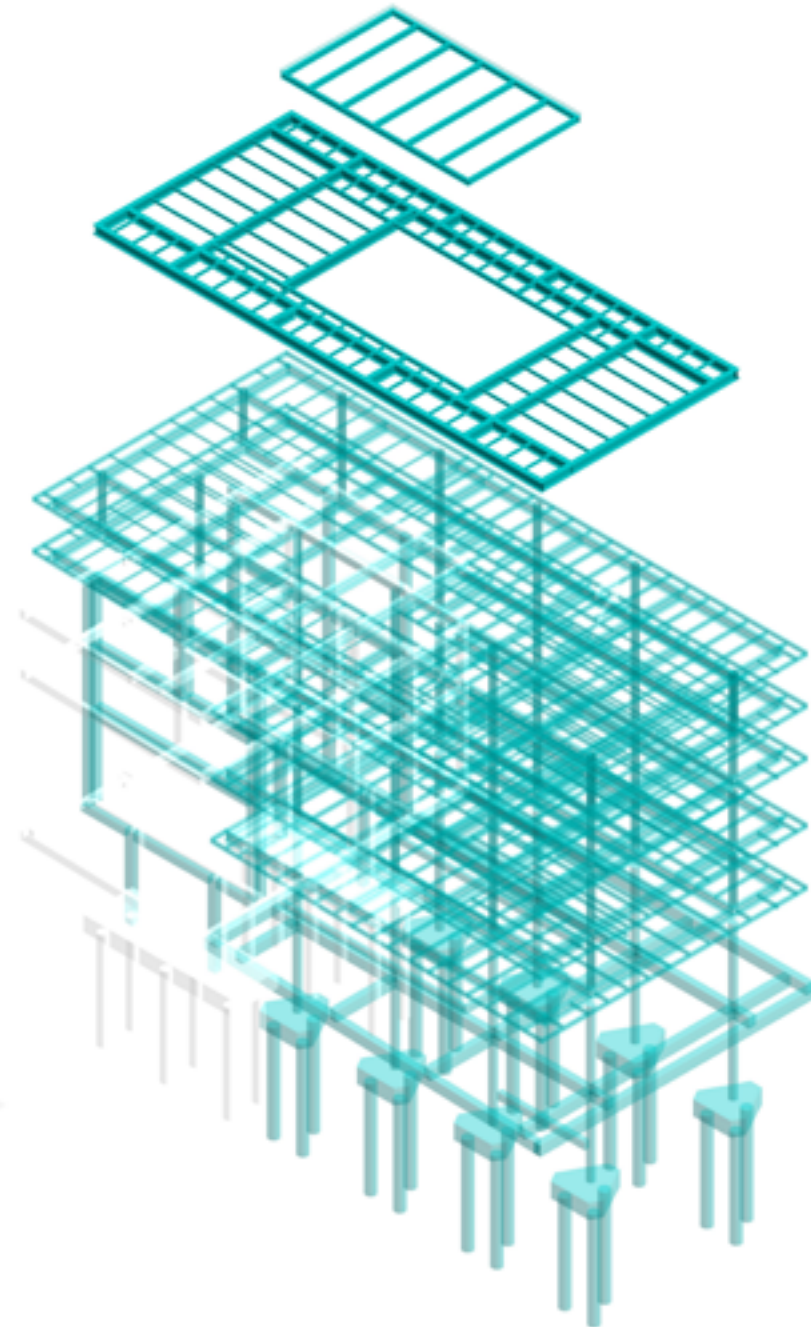

Estrutura cobertura e poço de luz

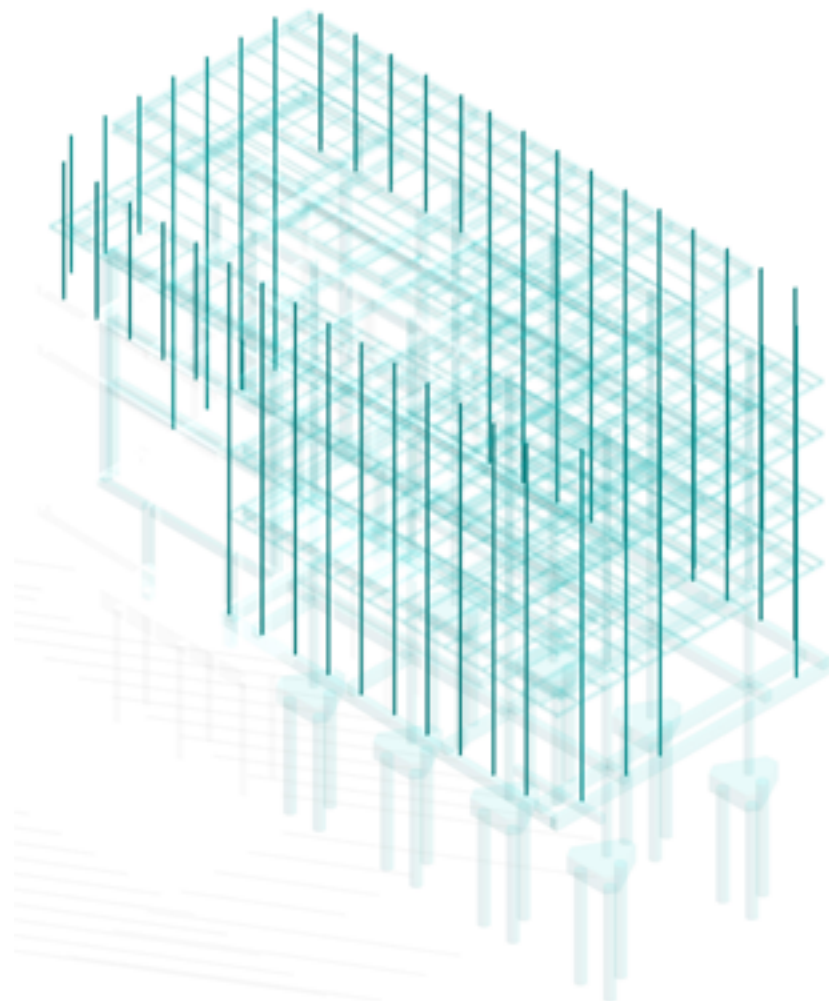

# Modulo Estrutura x Fachada

Toda a estrutura metalica devera possuir 3 camadas de pintura:

- anticorrosão
- intumescente (120h)
- acabamento

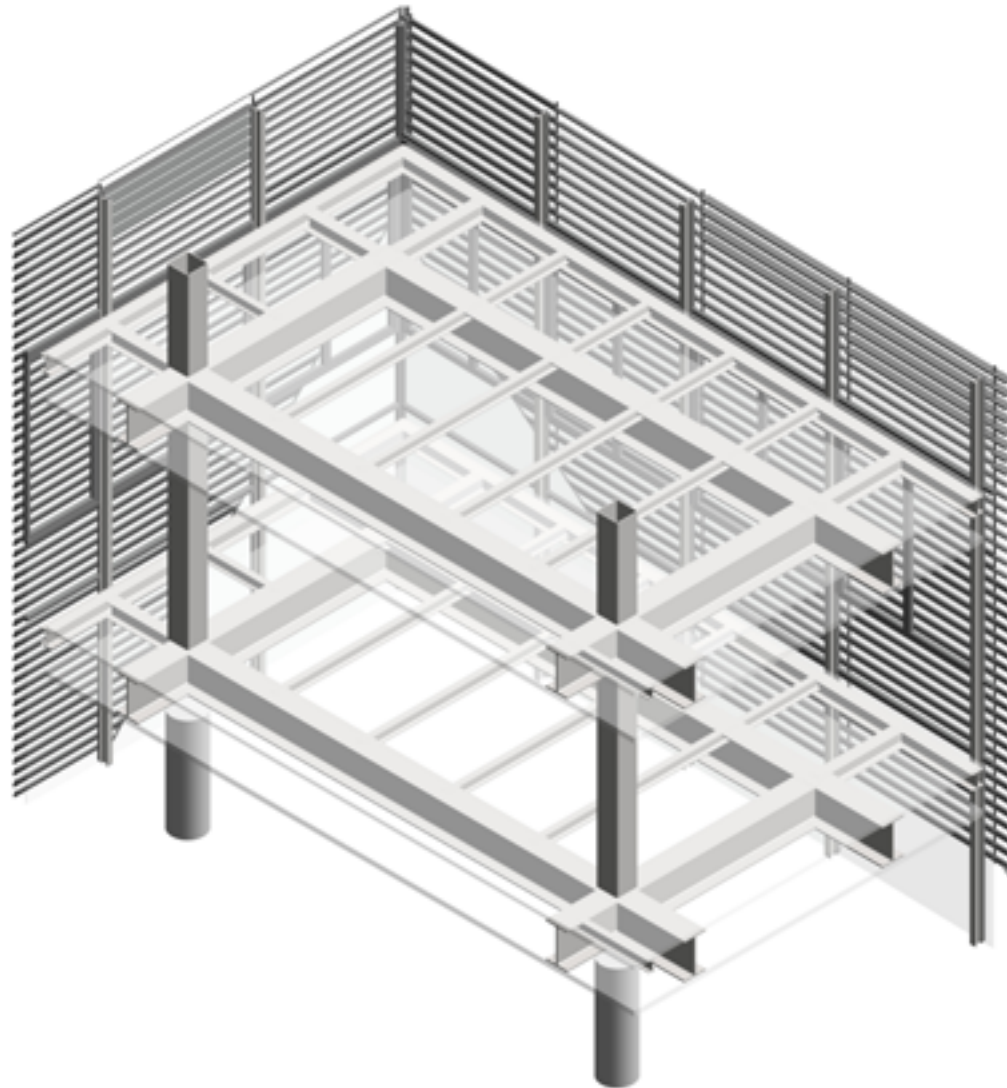

# Vigas principais perfil I

Vencendo vaos de 8,20m e 6,20 de tamanho regular para facilitar compra e montagem na obra

ESTRUTURA

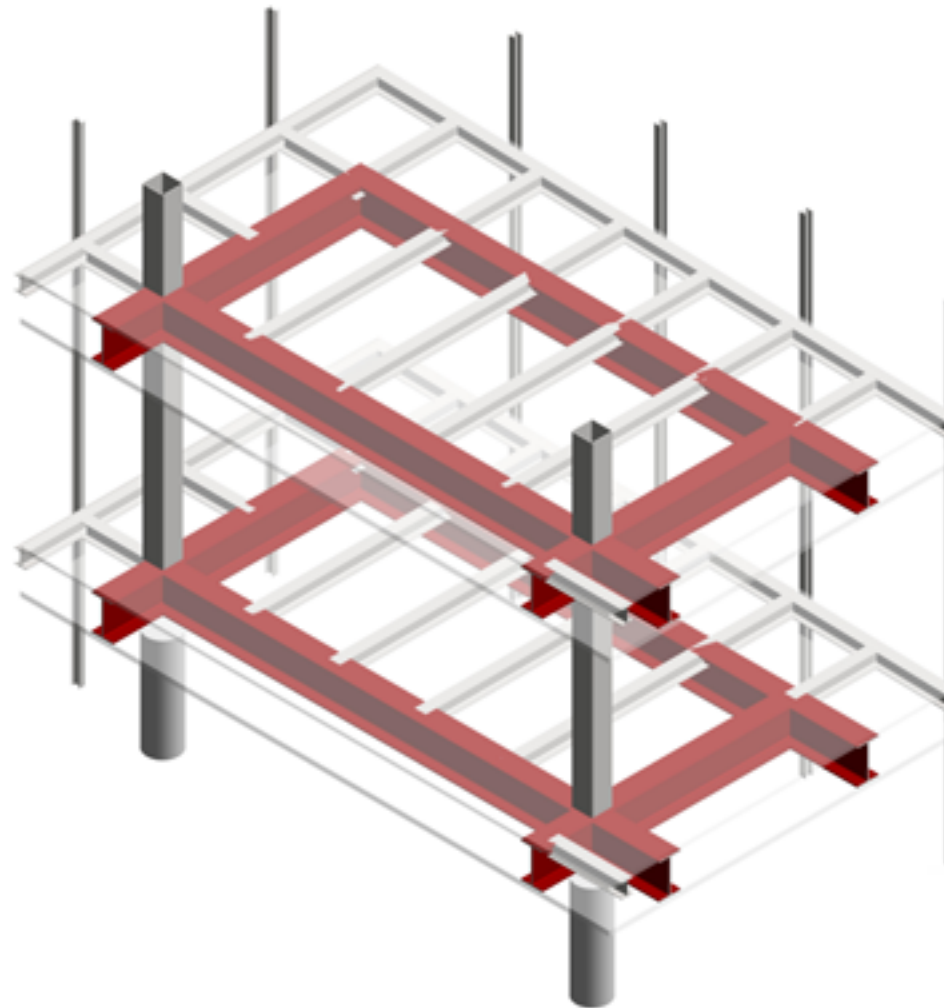

# Vigas secundarias perfil I

De tamanho regular para facilitar compra e montagem na obra

ESTRUTURA

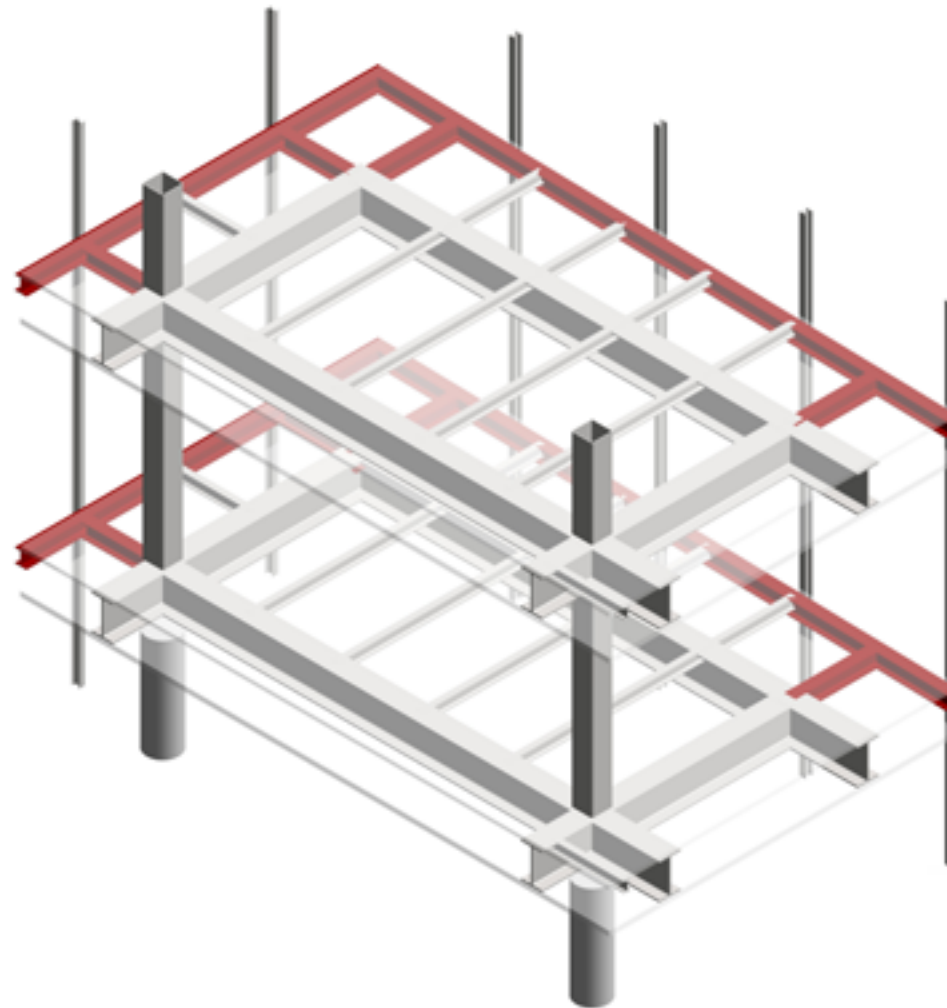



Vigas de  
suporte das  
lajes  
espaçadas em  
80 x 80

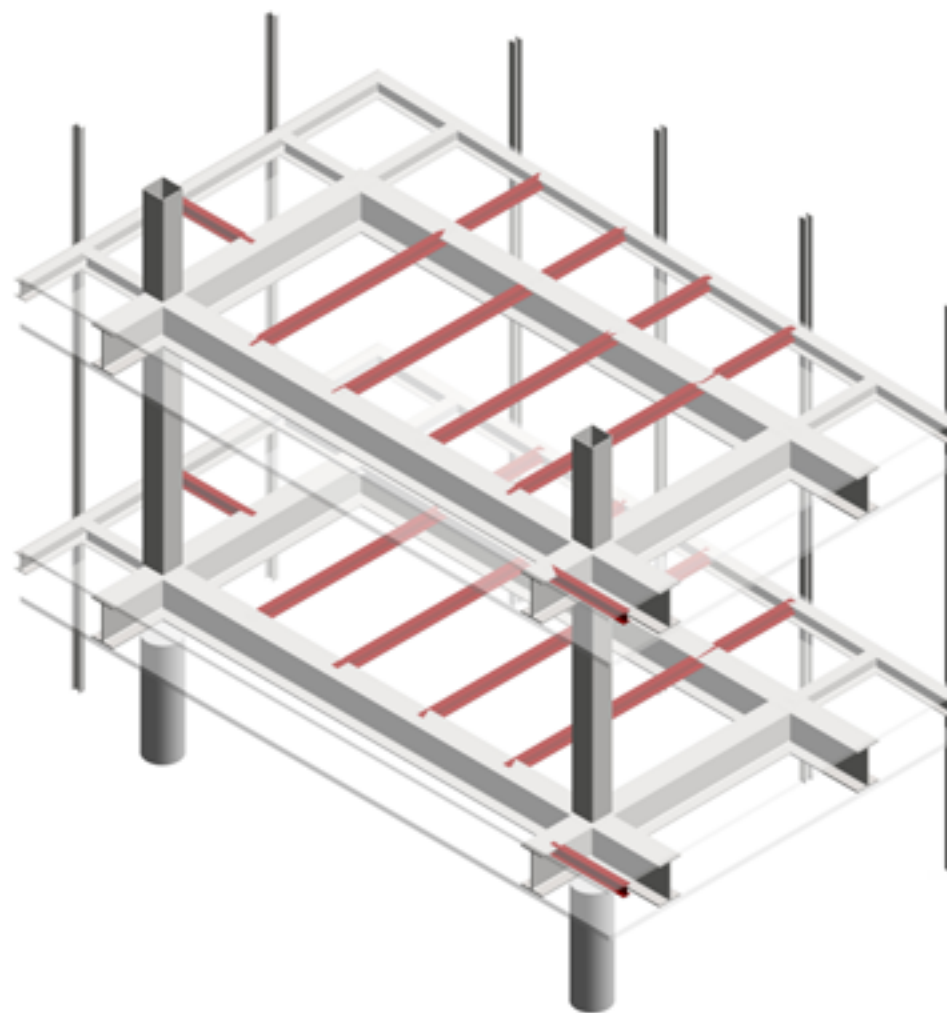

# Pilares metálicos principais perfil quadrado

ESTRUTURA

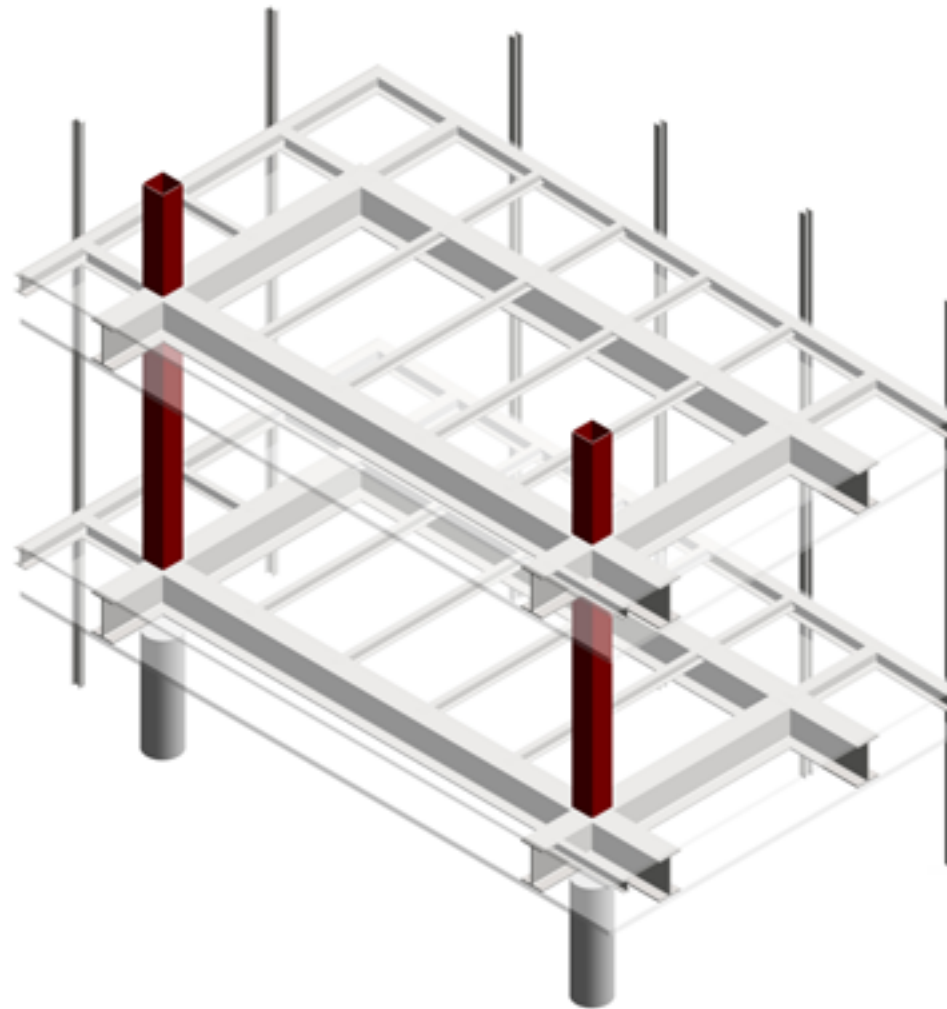

Pilares estrutura da fachada  
perfil I espaçados de 220cm

ESTRUTURA

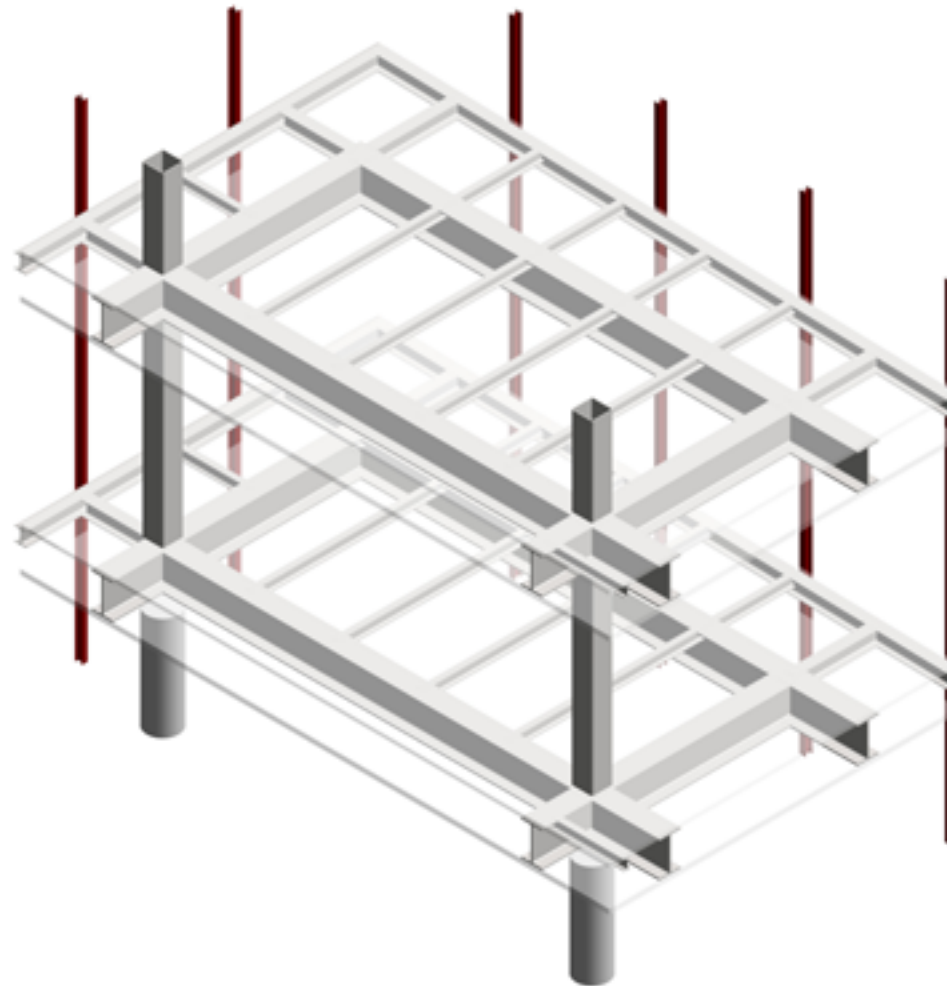

# Esquadrias de vidro da fachada fixadas nos pilares de sustentação da fachada

ESTRUTURA

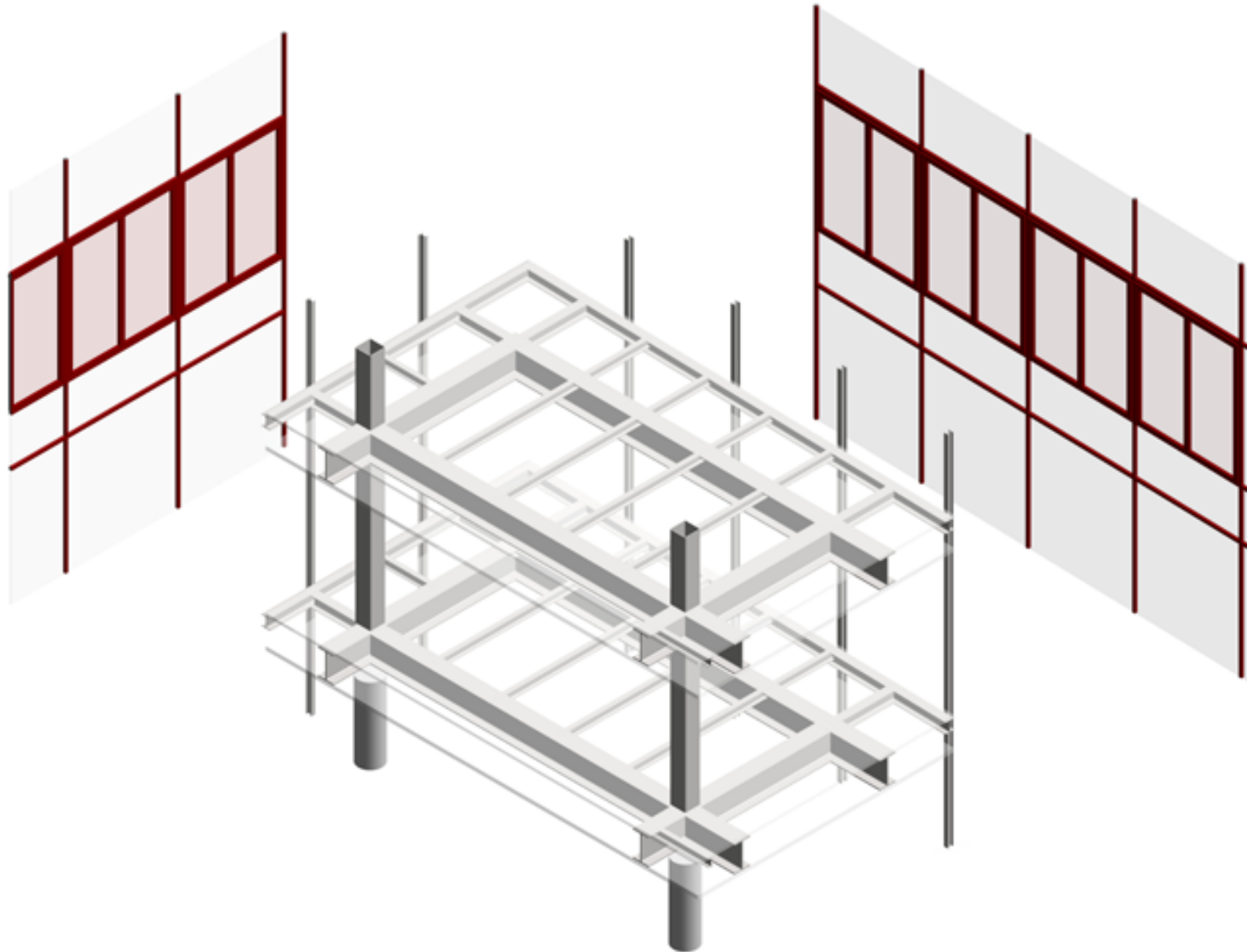

# Brises de lamelas de madeiras

estruturados com perfis fixados nos montantes das esquadrias de vidro

ESTRUTURA

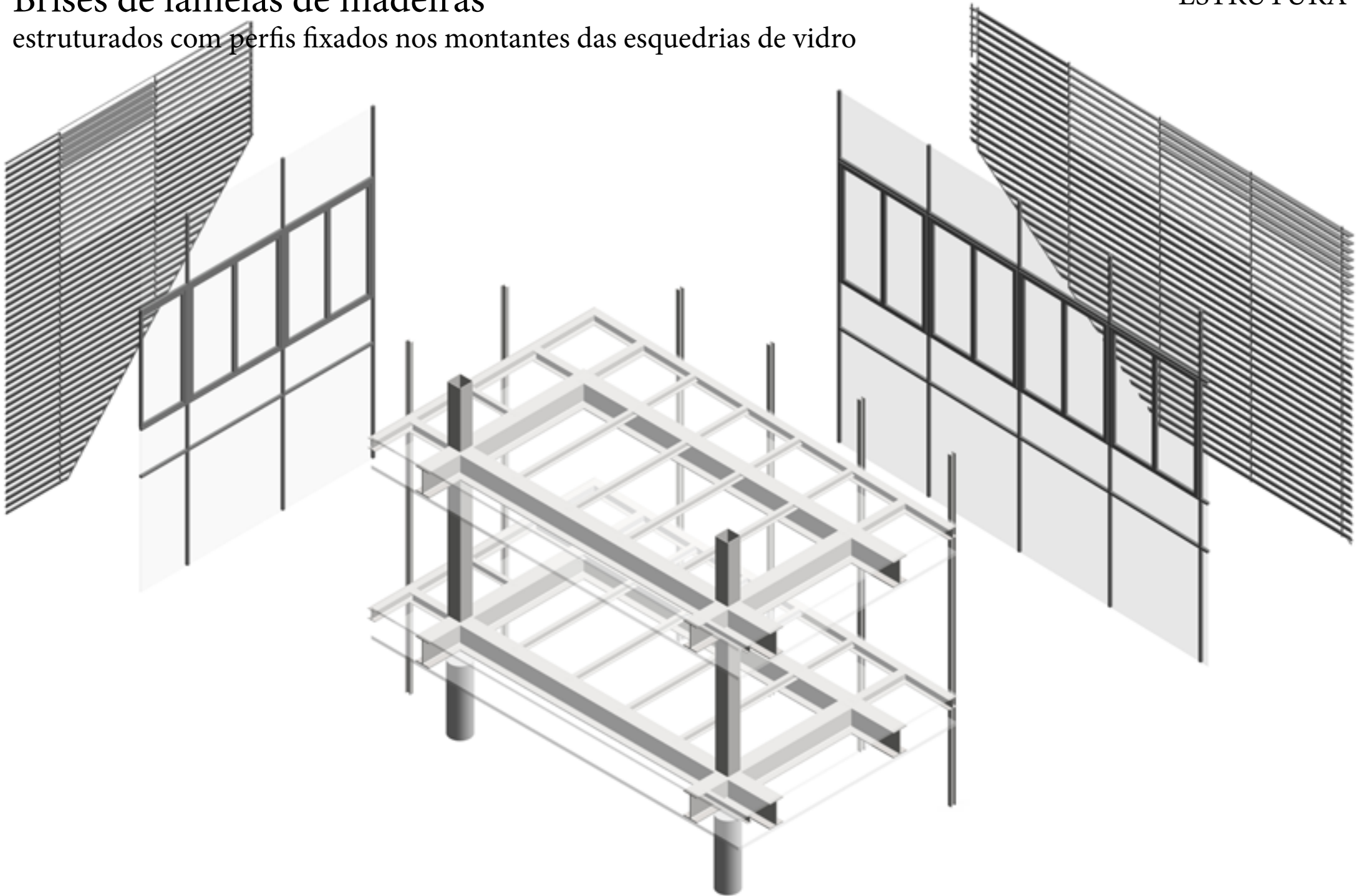

# DETALHAMENTOS FACHADA X COBERTURA

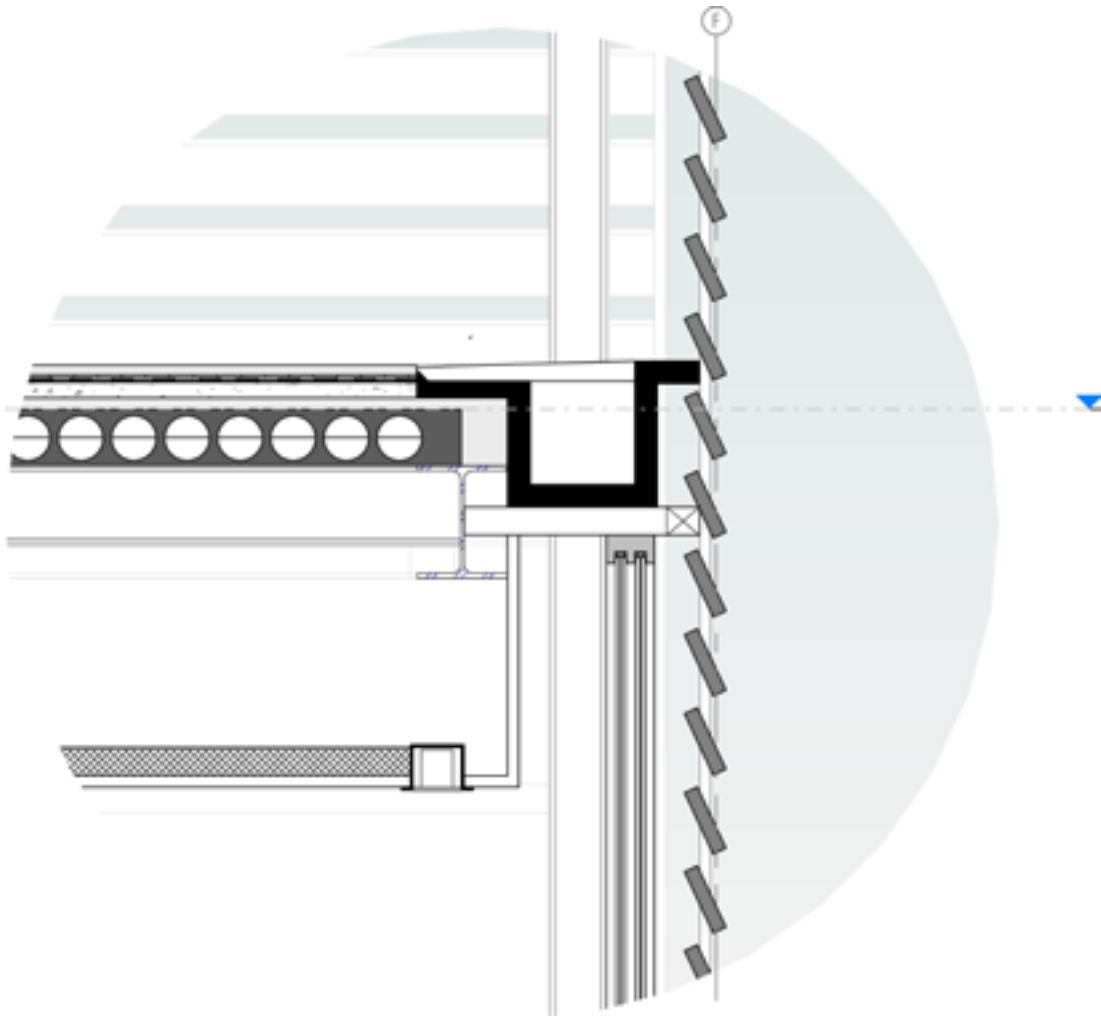

# DETALHAMENTOS FACHADA X COBERTURA

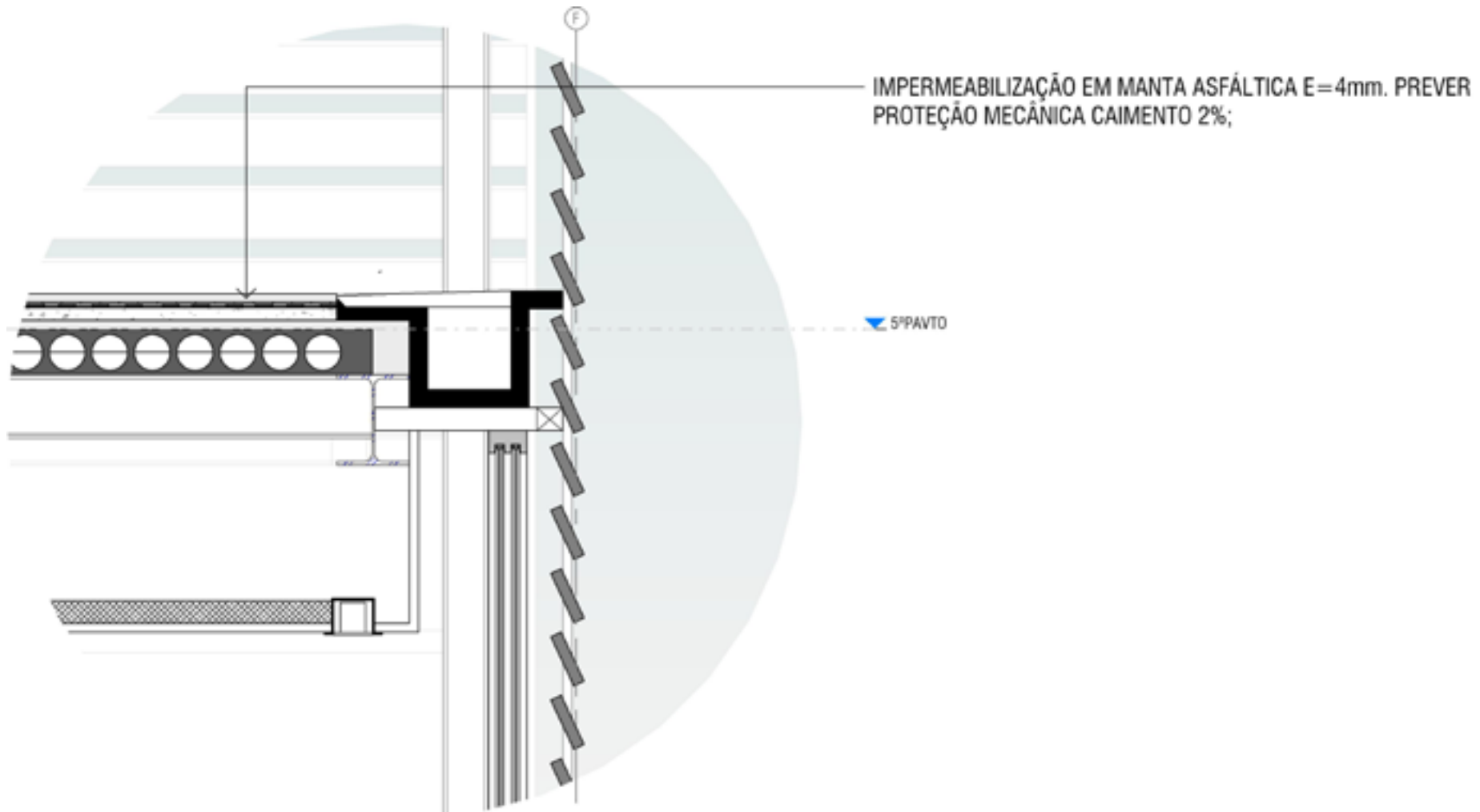

# DETALHAMENTOS FACHADA X COBERTURA

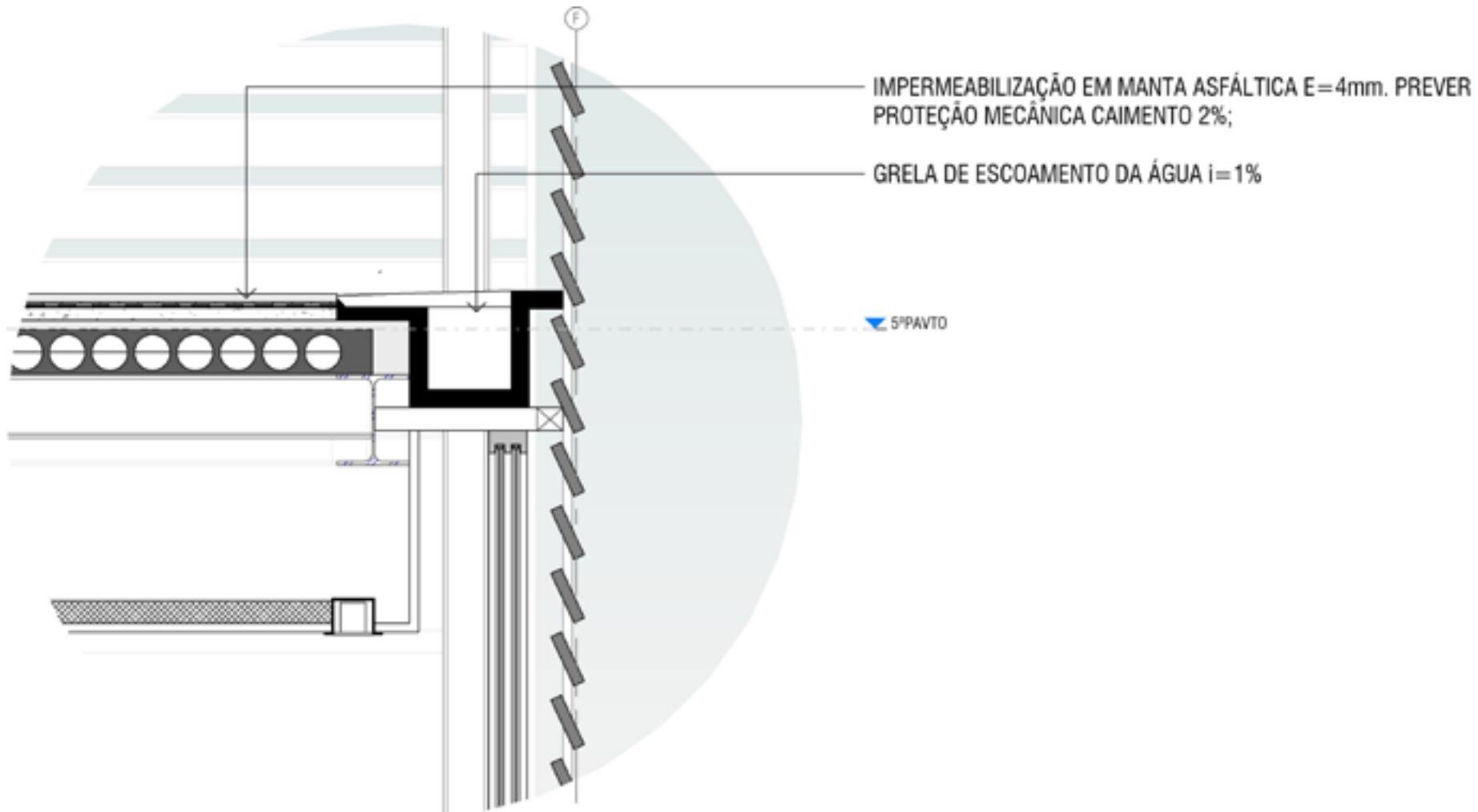



# DETALHAMENTOS FACHADA X COBERTURA

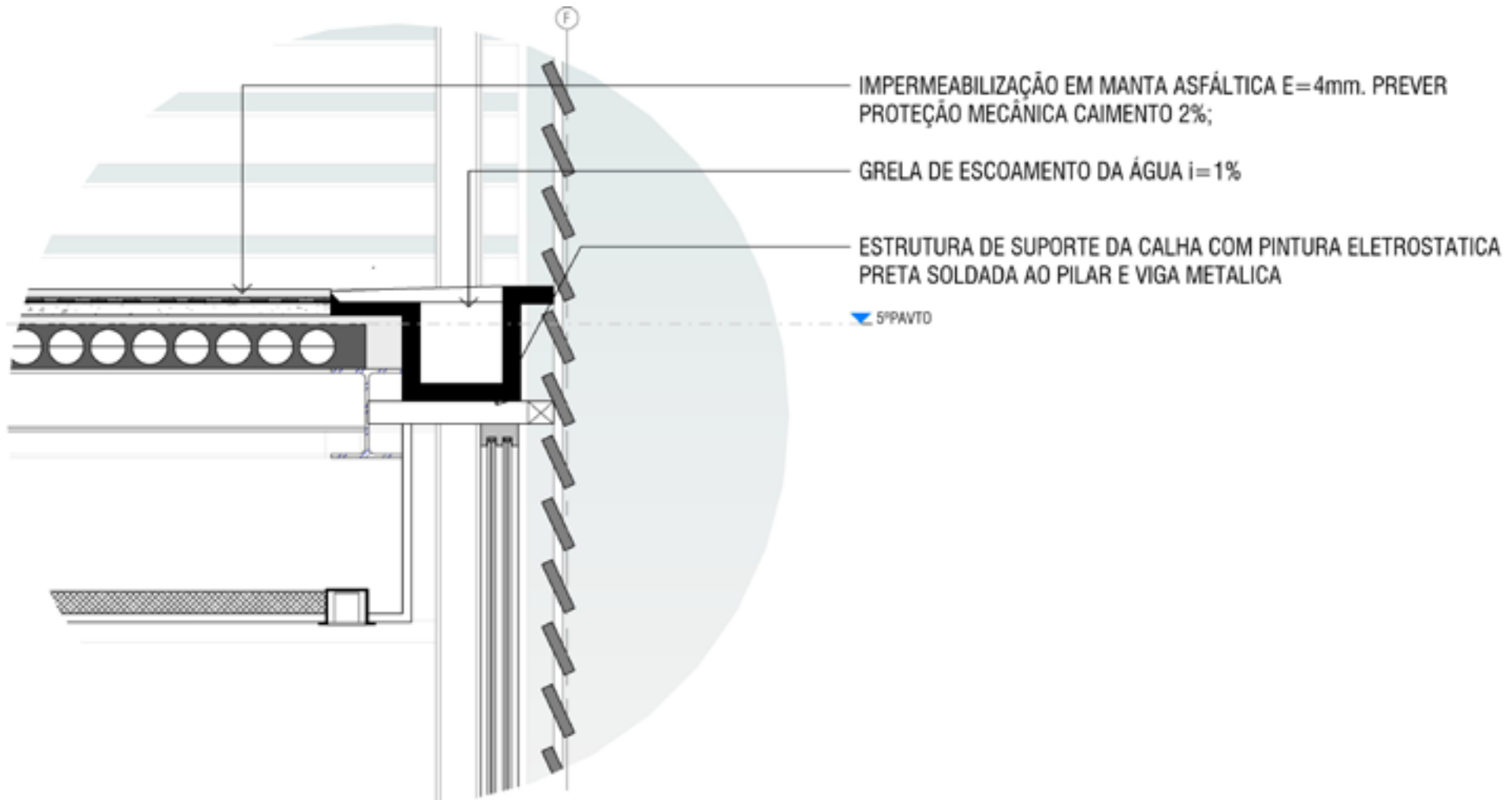

# DETALHAMENTOS FACHADA X COBERTURA

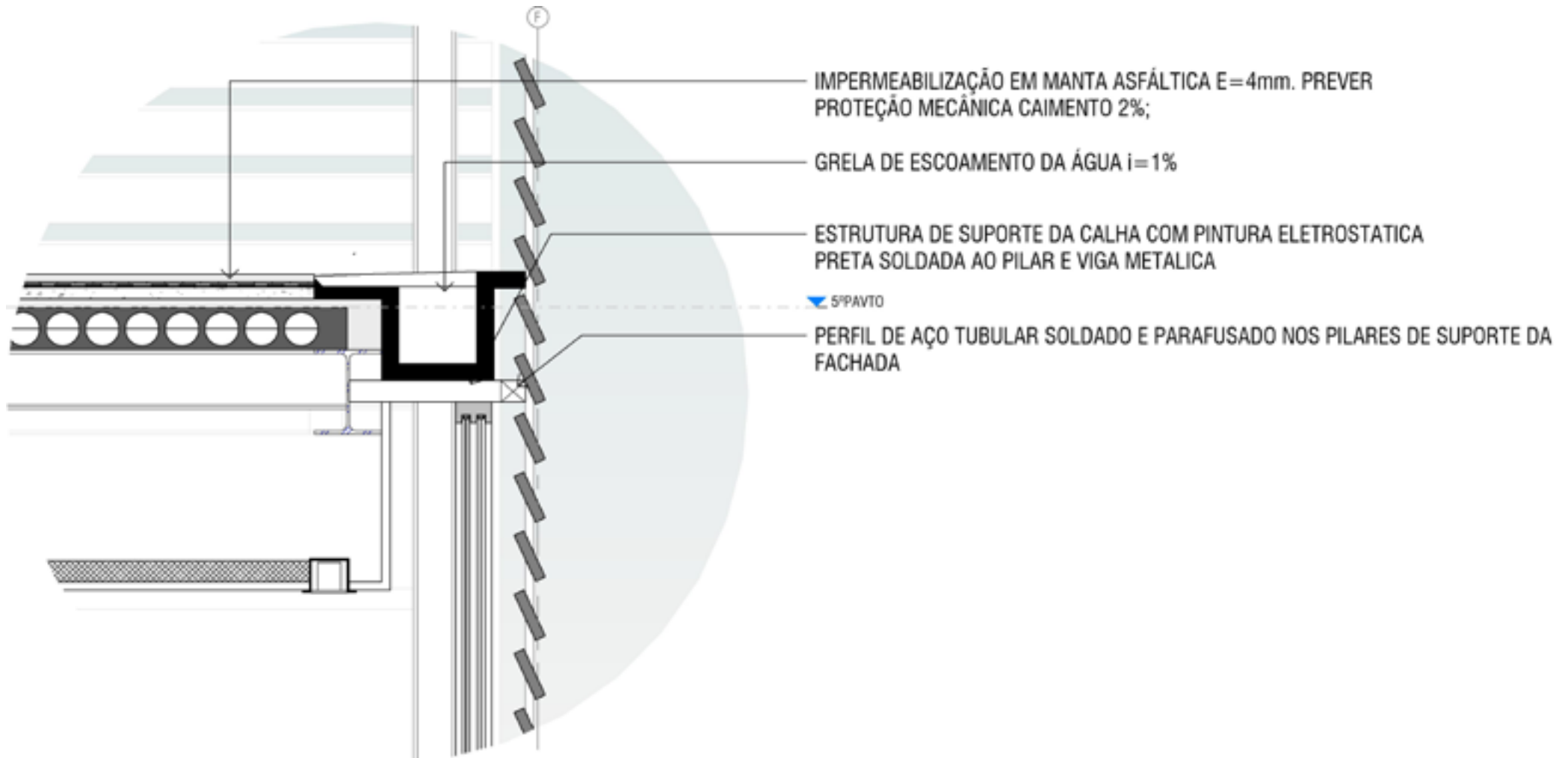

# DETALHAMENTOS FACHADA X COBERTURA

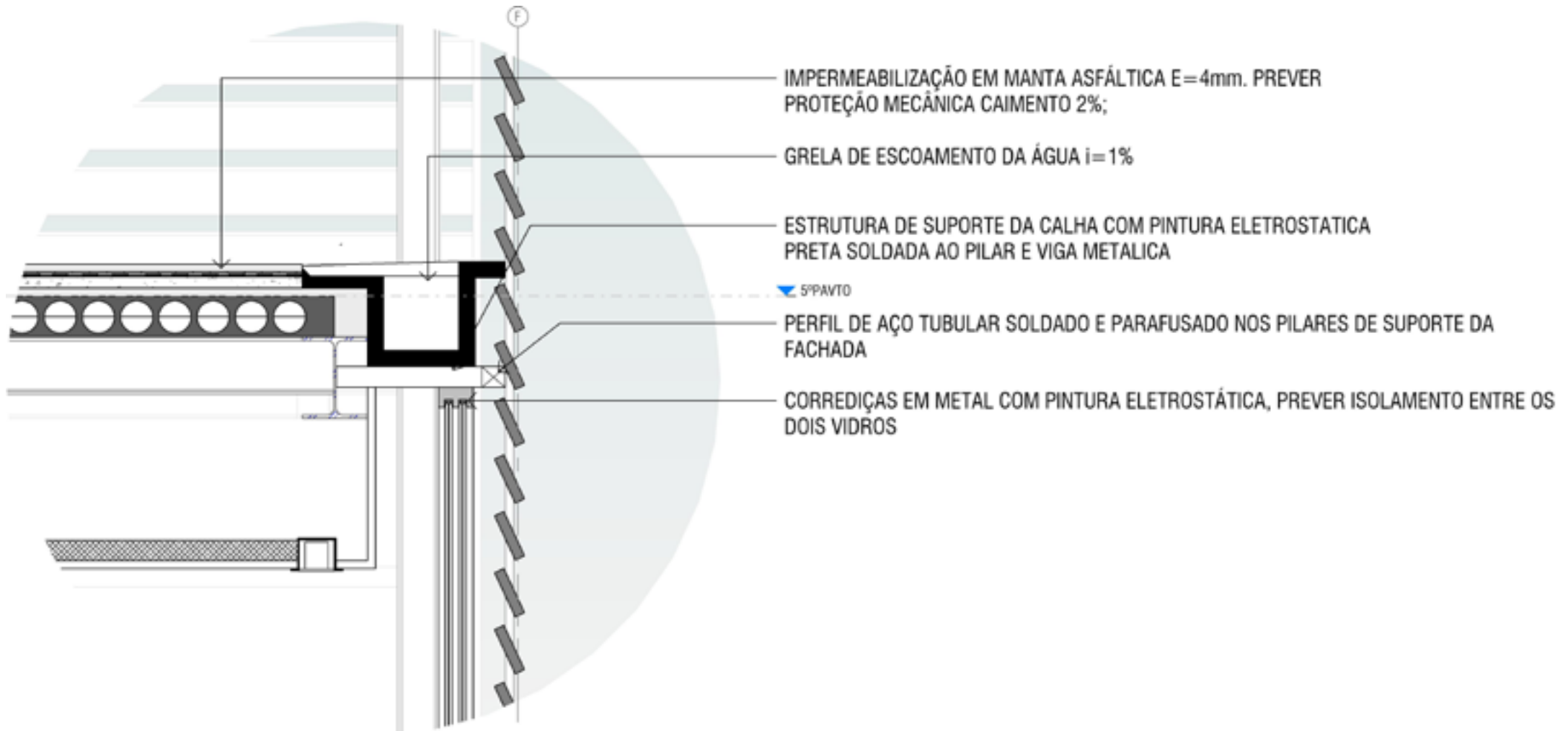

# DETALHAMENTOS FACHADA X COBERTURA

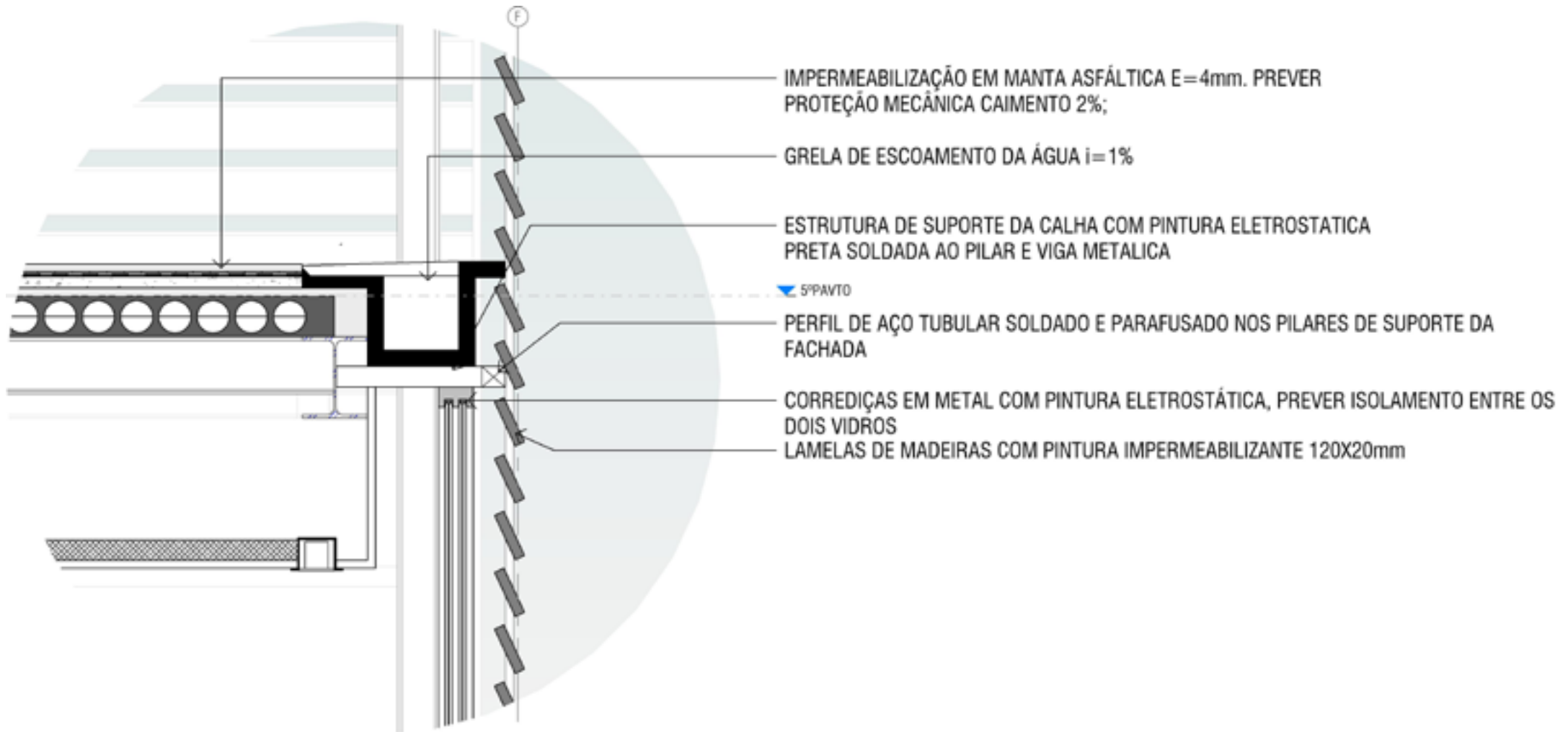



# DETALHAMENTOS FACHADA X COBERTURA

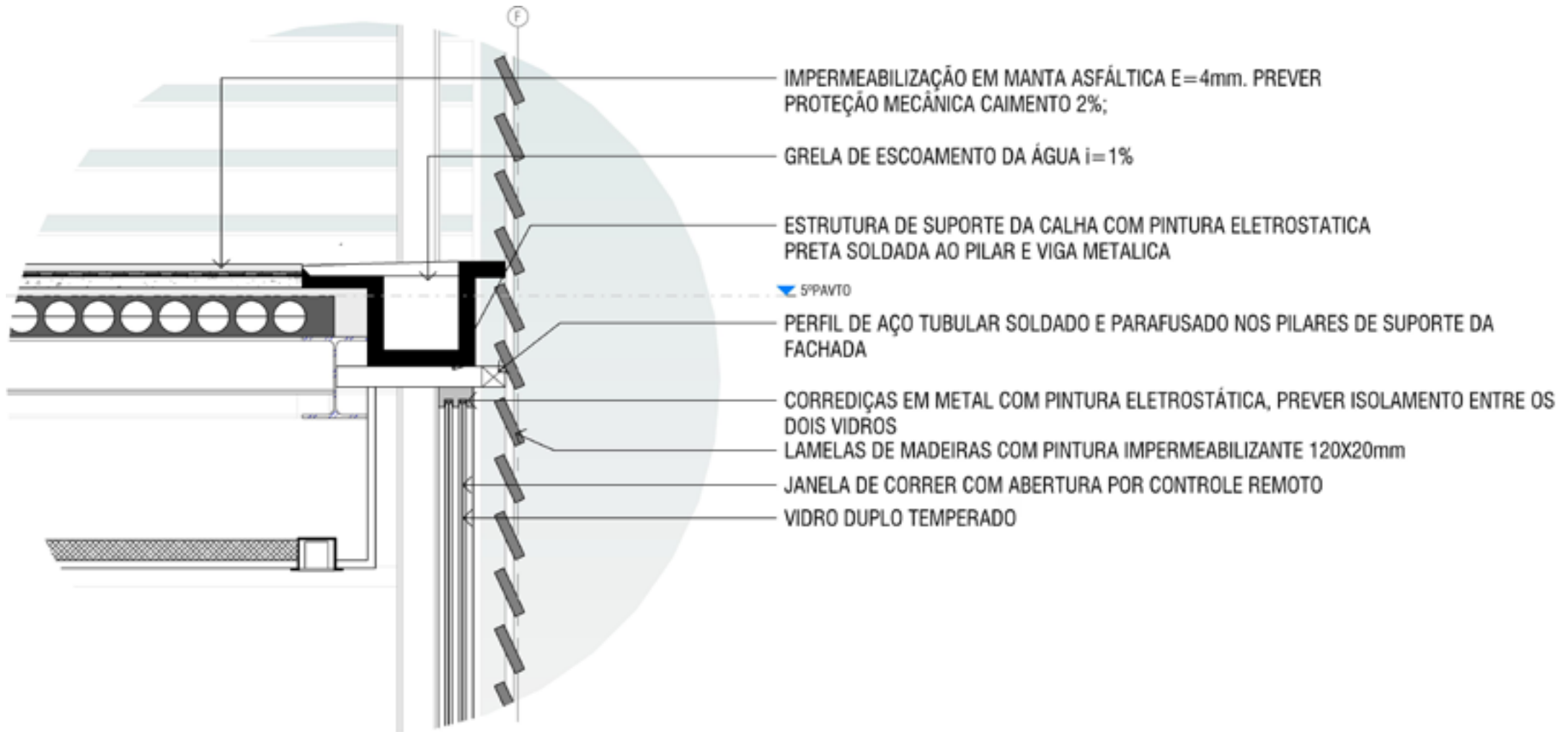

# DETALHAMENTOS FACHADA X COBERTURA

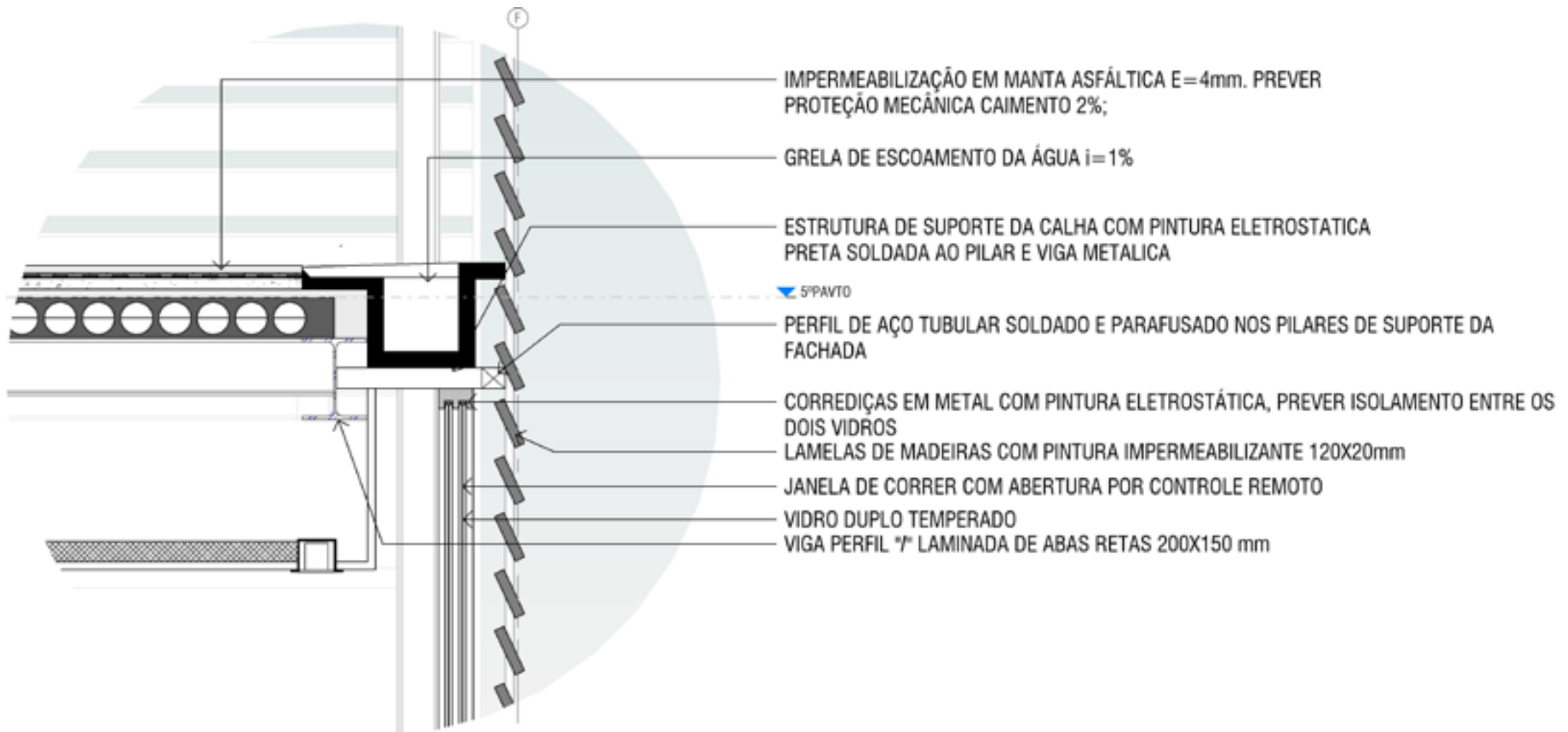

# DETALHAMENTOS FACHADA X COBERTURA

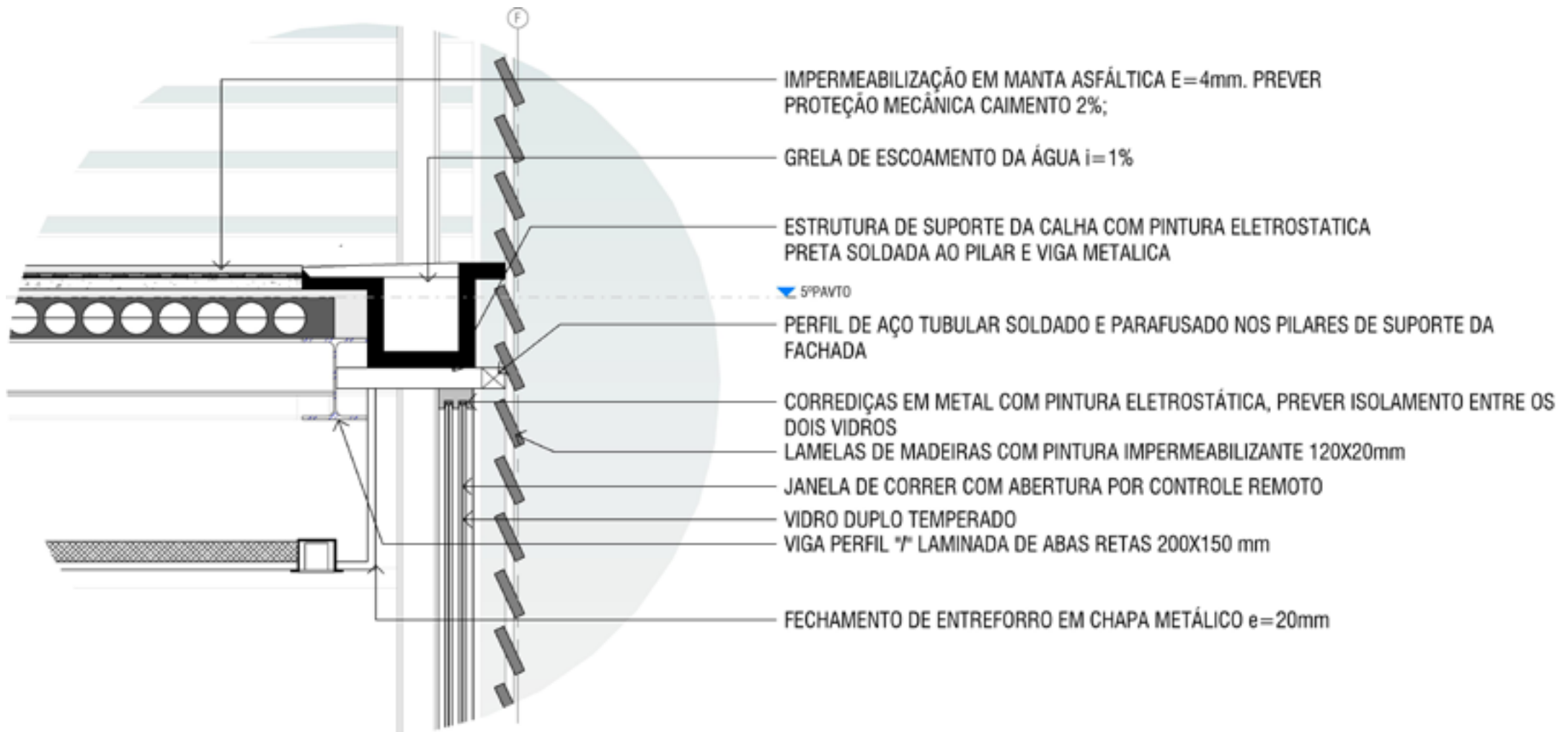



# DETALHAMENTOS FACHADA X COBERTURA

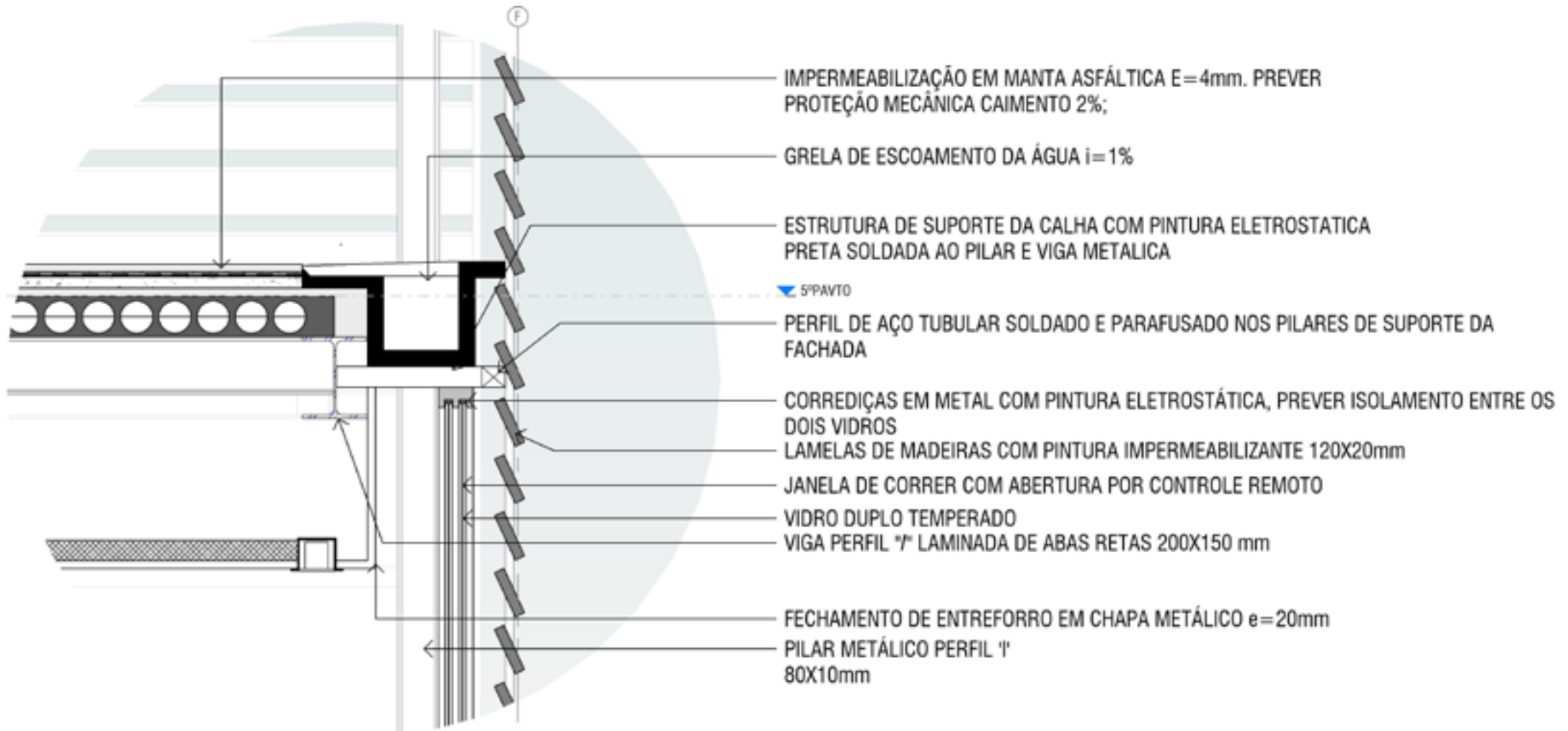

DETALHAMENTOS  
EXISTENTE X NOVO

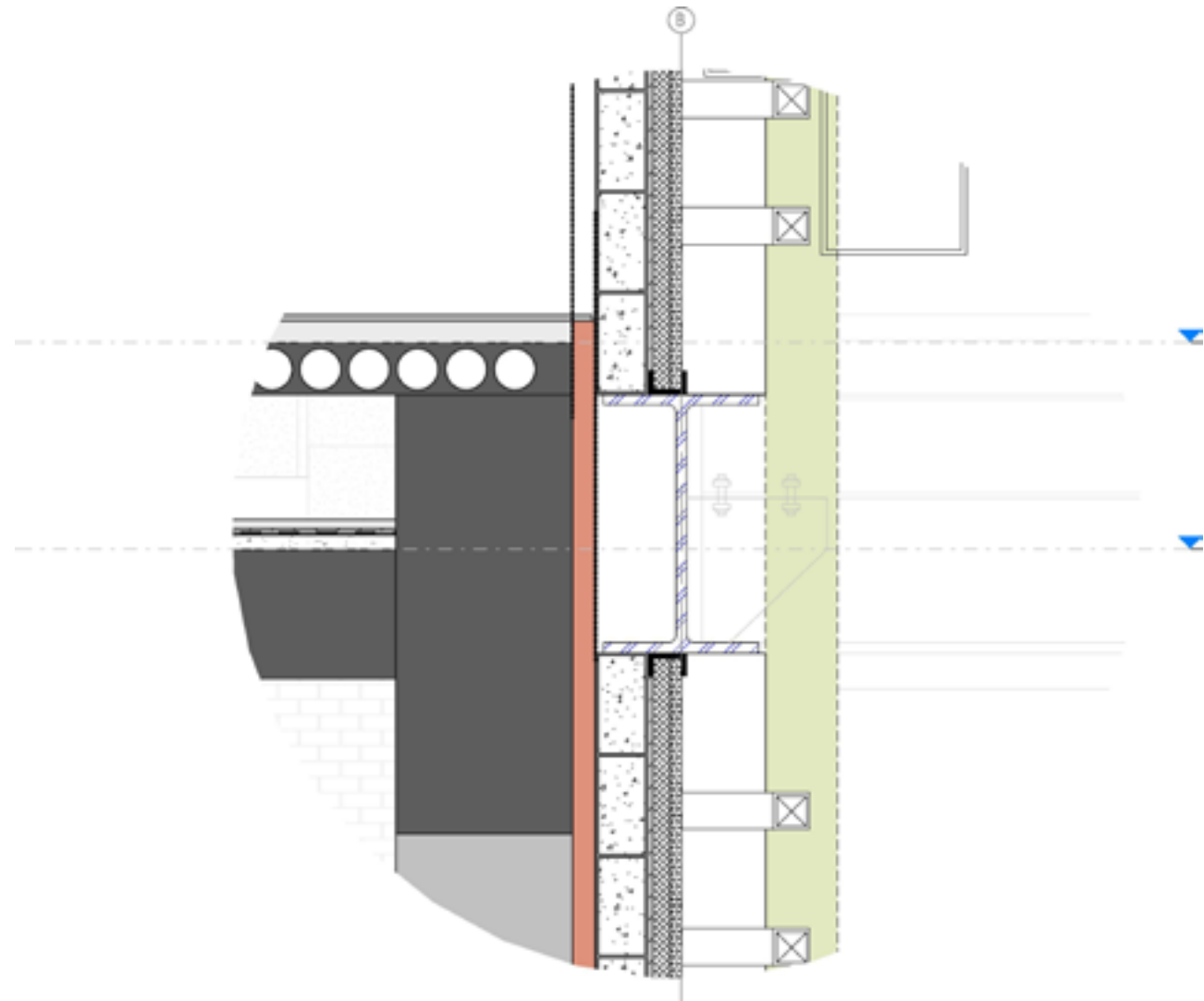

# DETALHAMENTOS EXISTENTE X NOVO

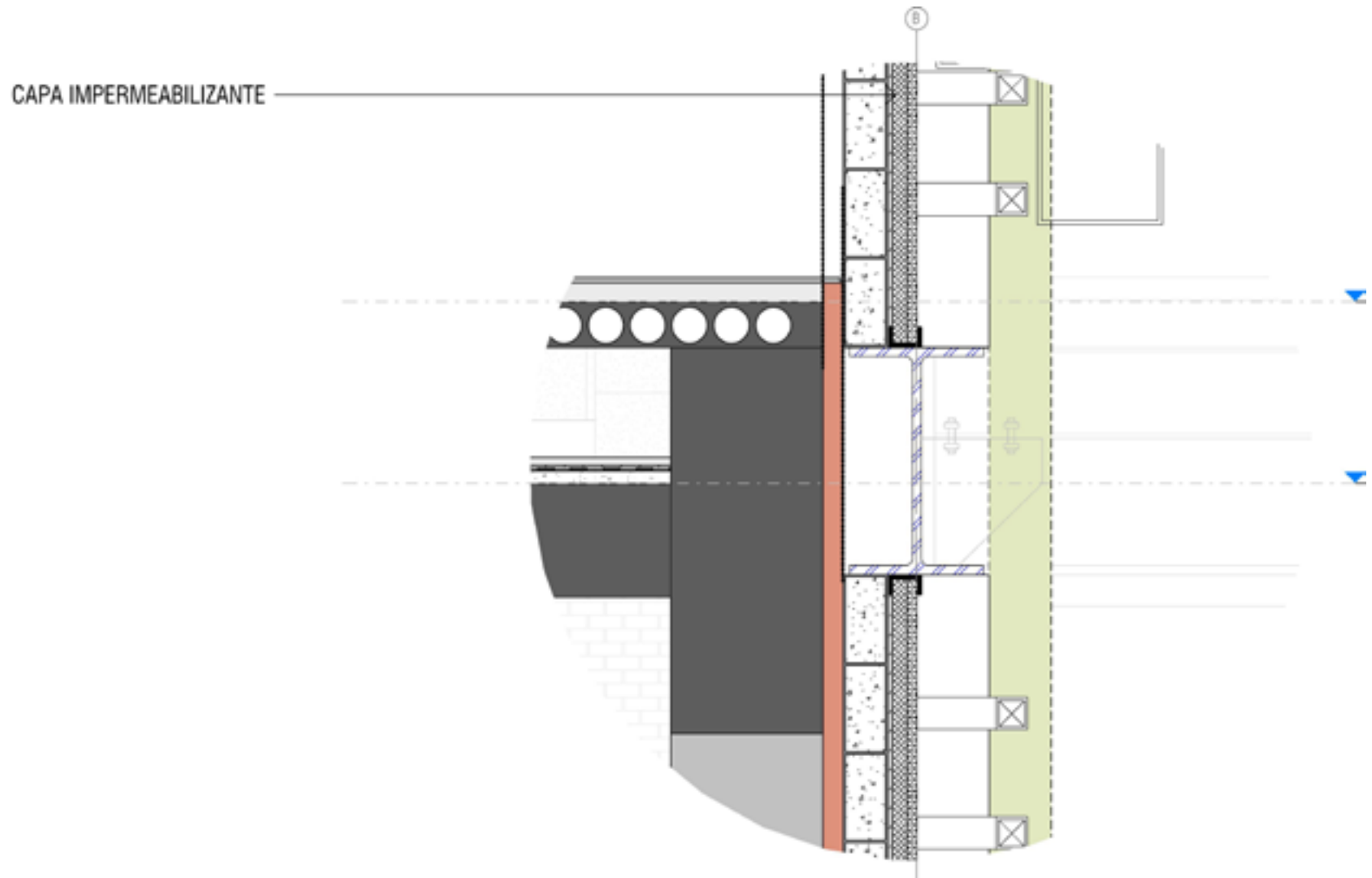

# DETALHAMENTOS EXISTENTE X NOVO

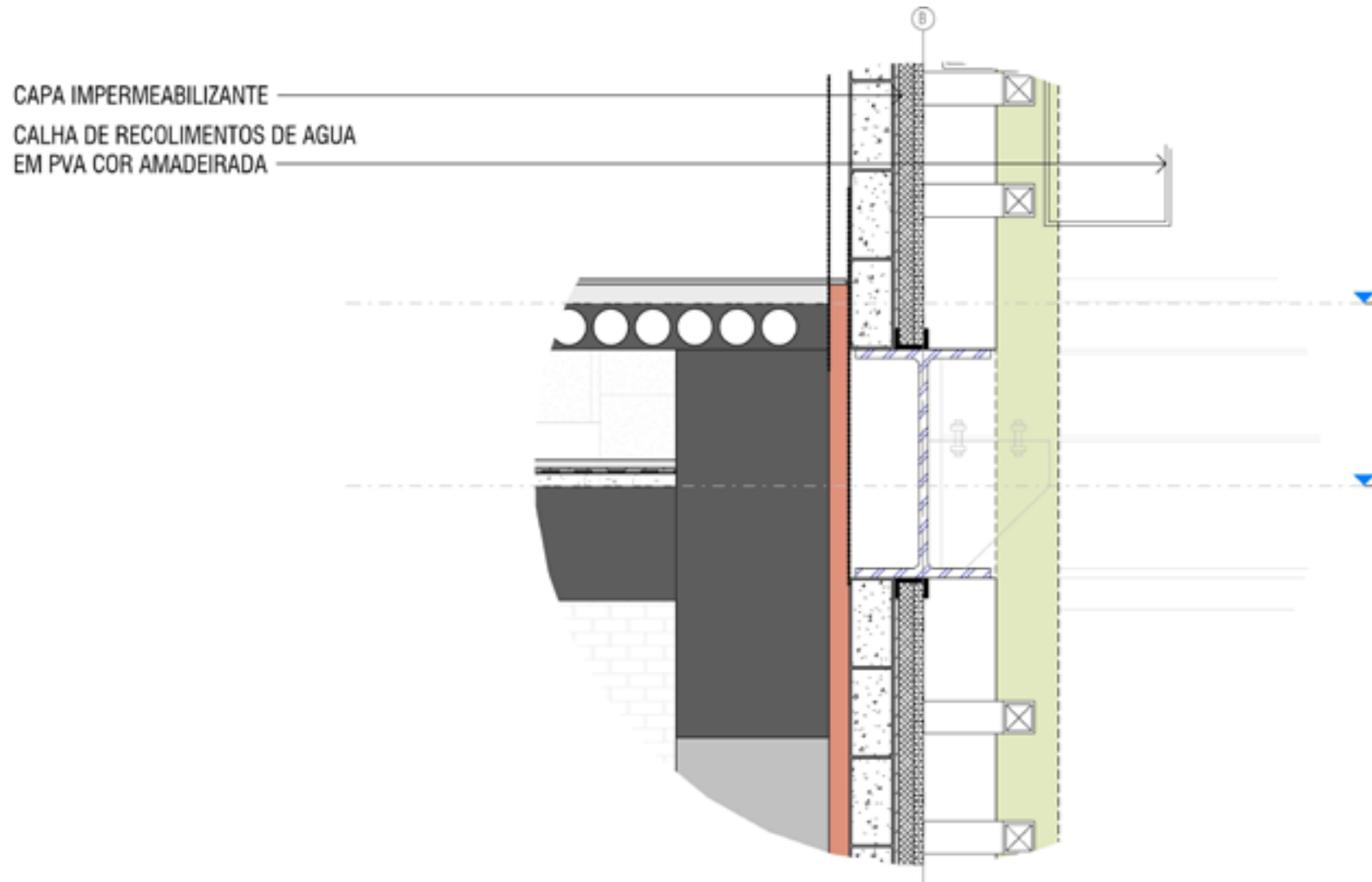

# DETALHAMENTOS EXISTENTE X NOVO

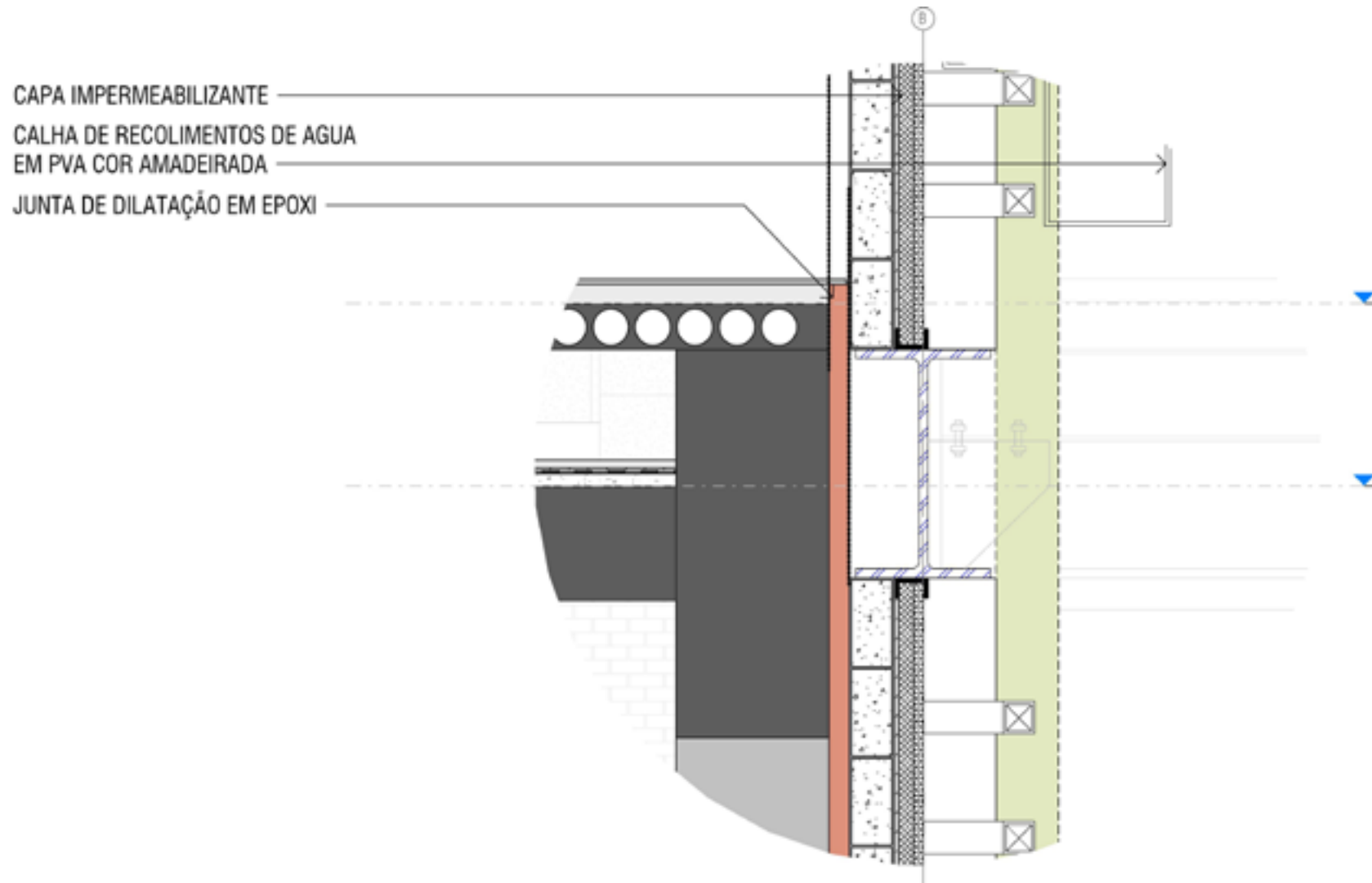

# DETALHAMENTOS EXISTENTE X NOVO

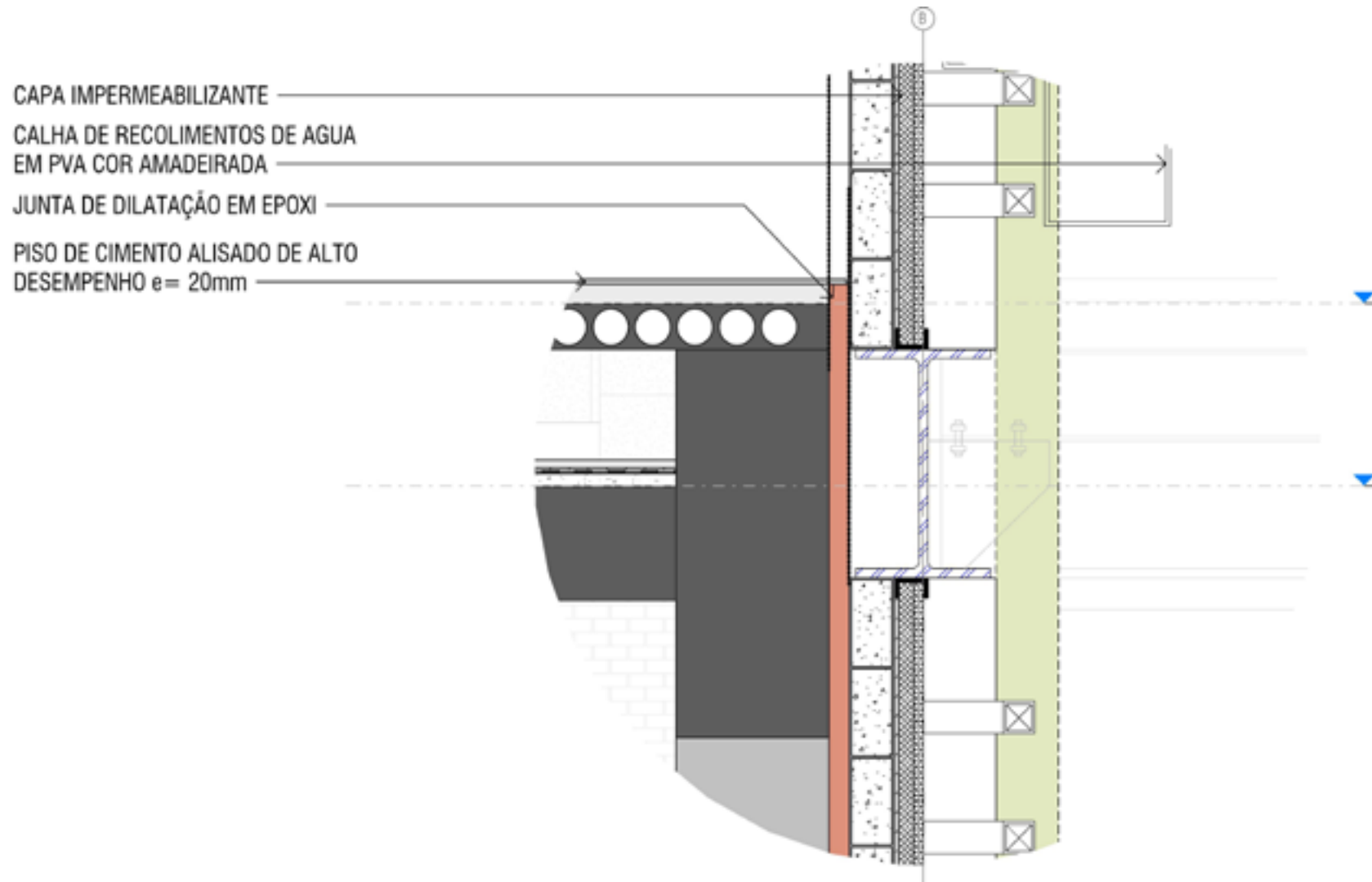

# DETALHAMENTOS EXISTENTE X NOVO

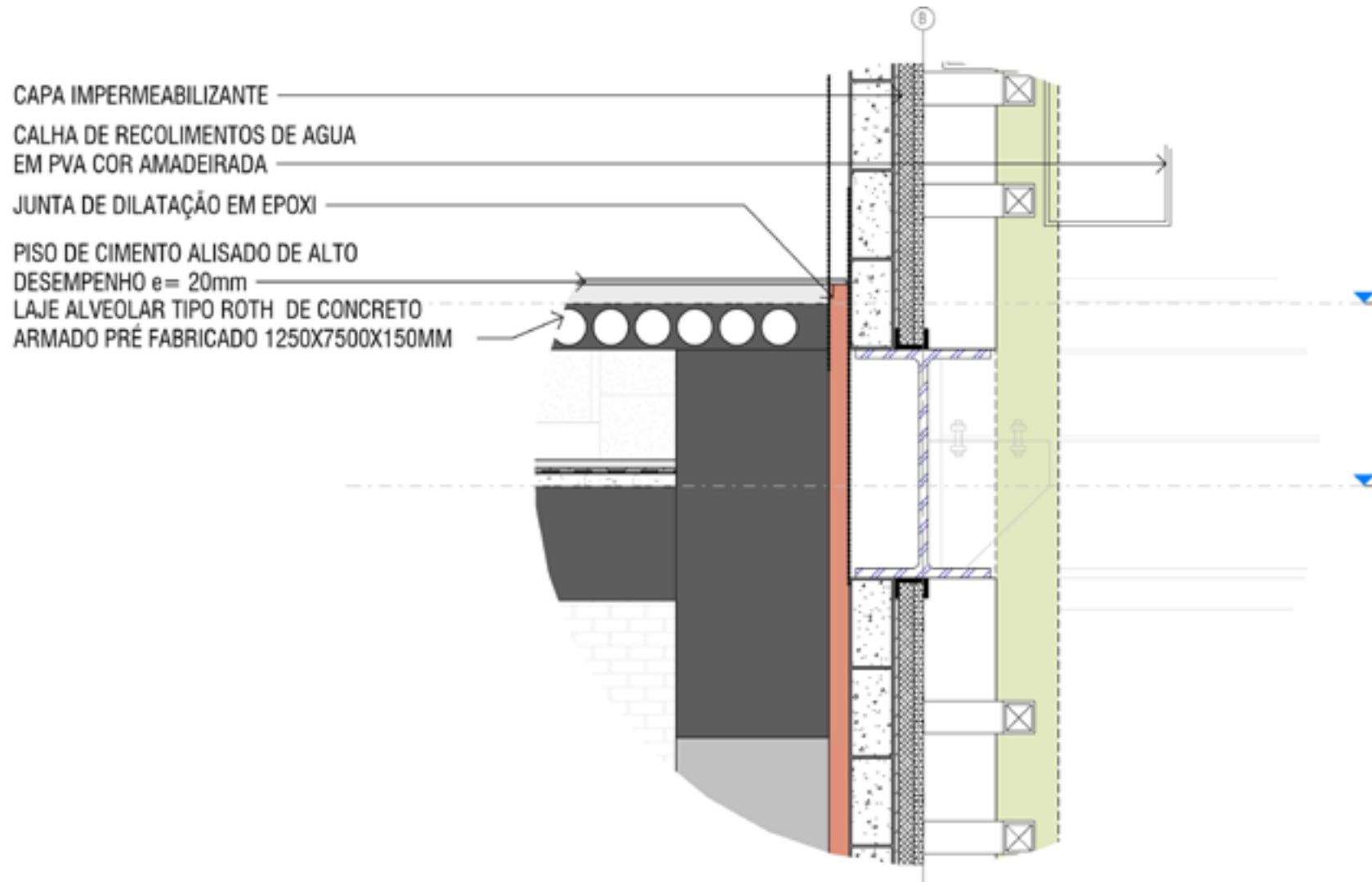

# DETALHAMENTOS EXISTENTE X NOVO

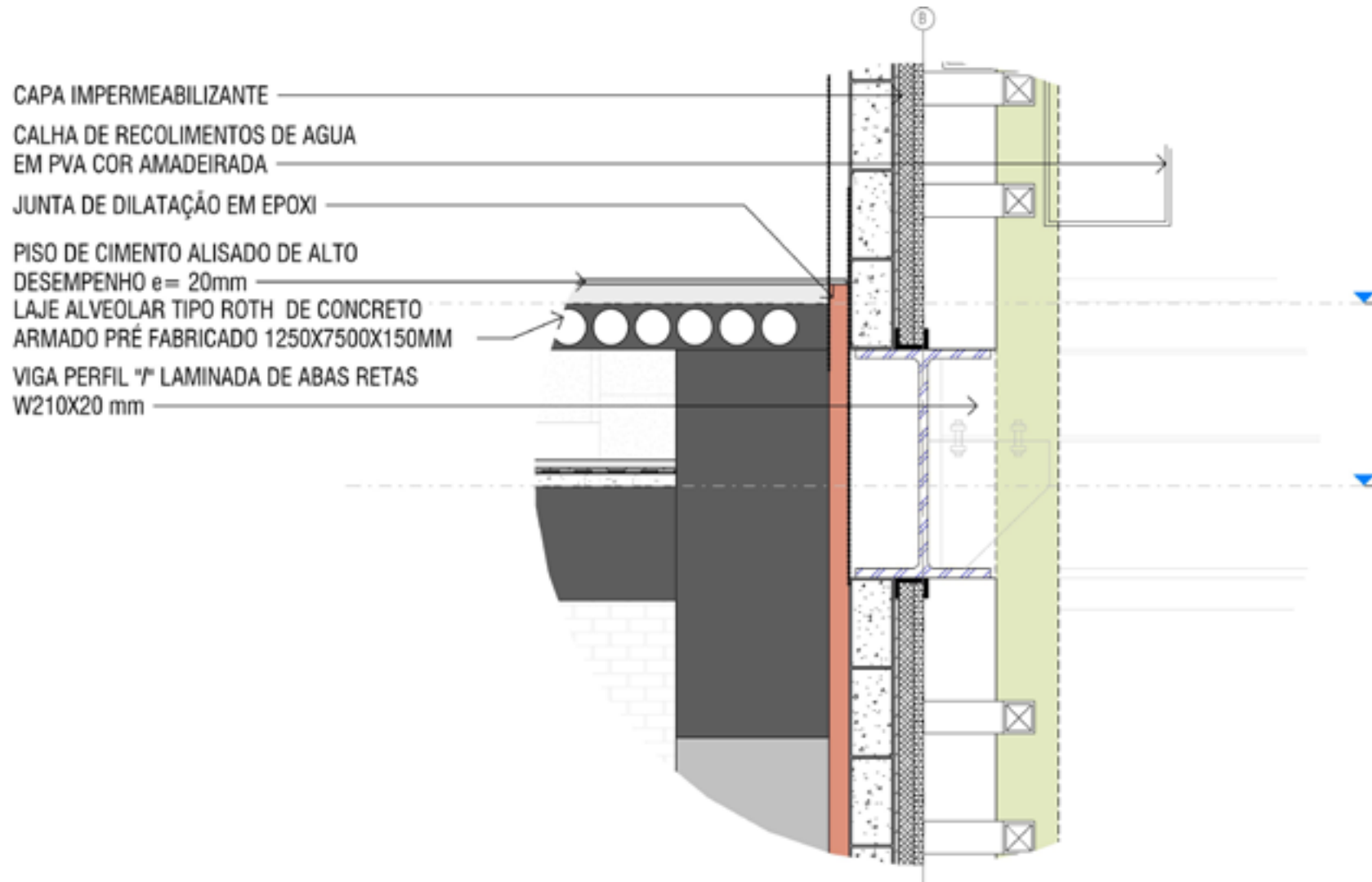



# DETALHAMENTOS EXISTENTE X NOVO

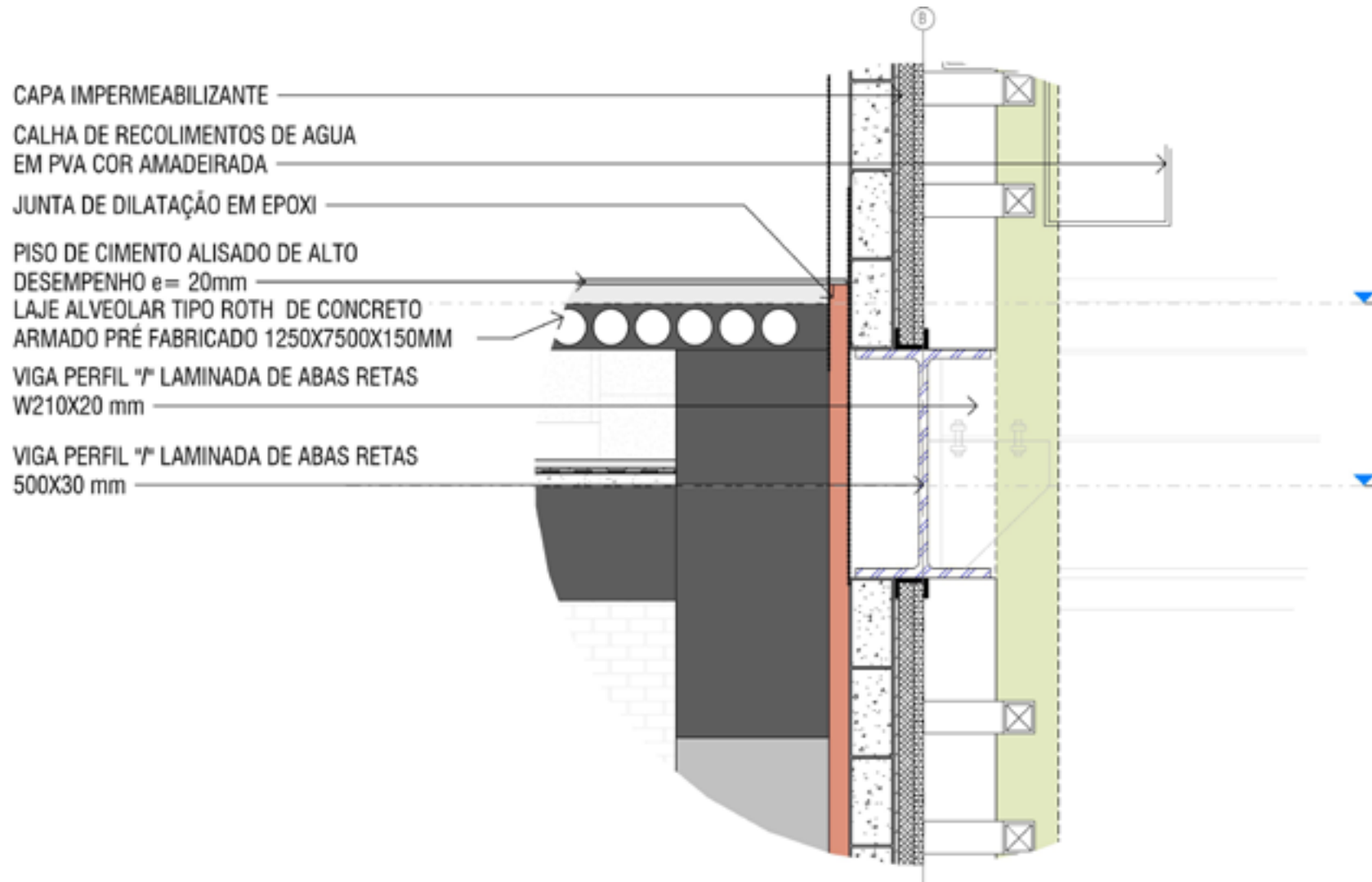

# DETALHAMENTOS EXISTENTE X NOVO

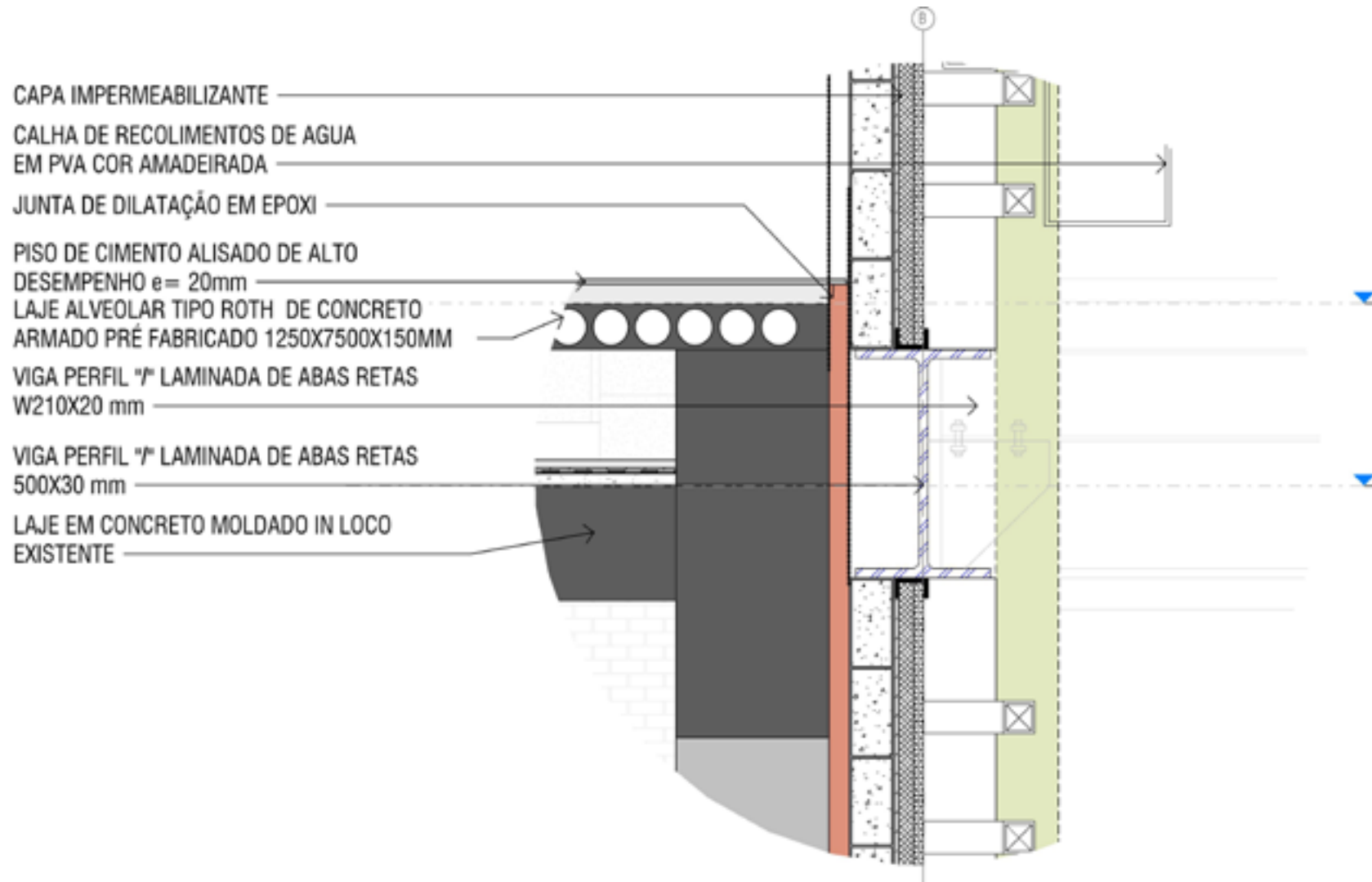

# DETALHAMENTOS EXISTENTE X NOVO

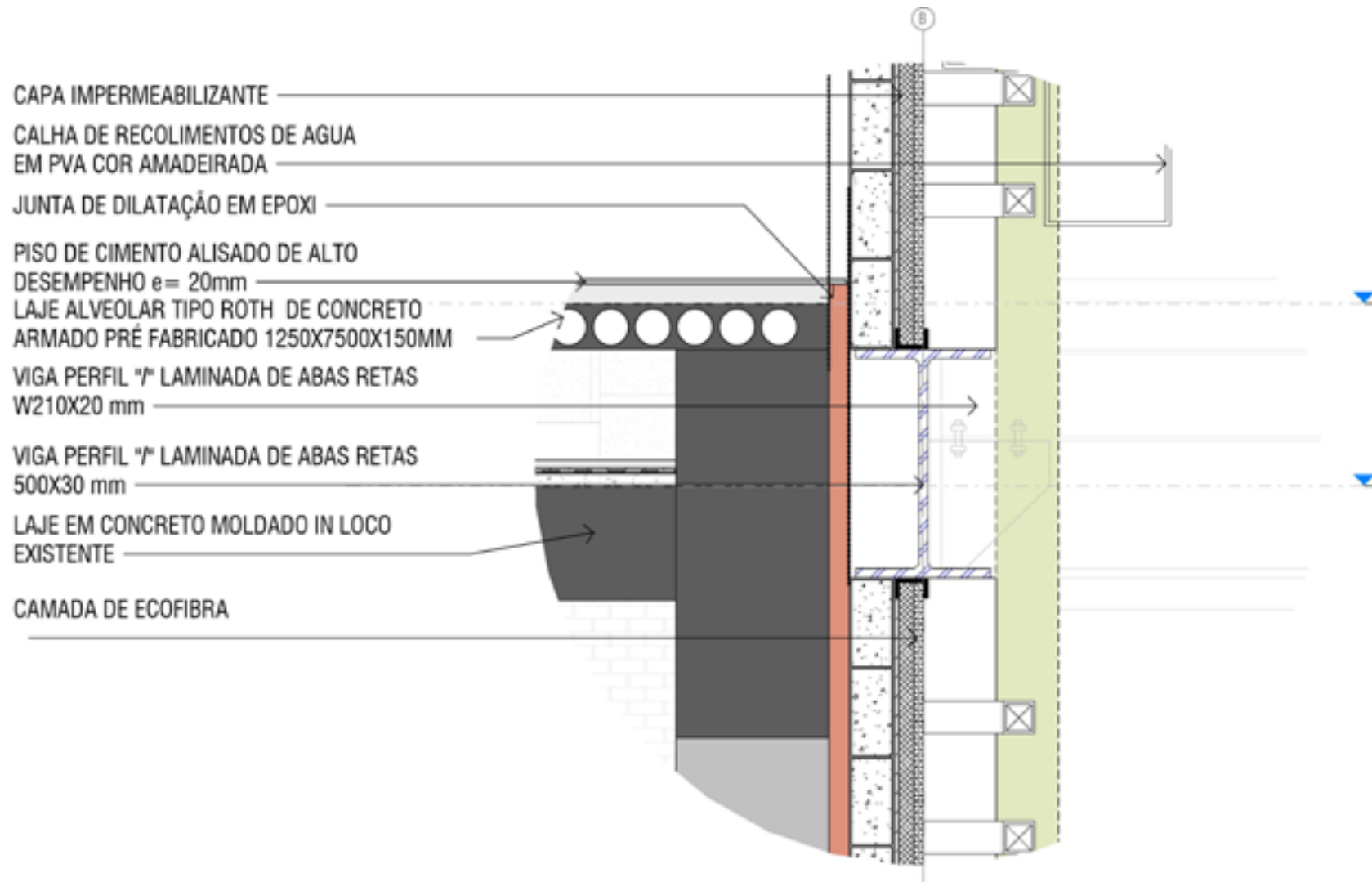

# DETALHAMENTOS FACHADA X COBERTURA

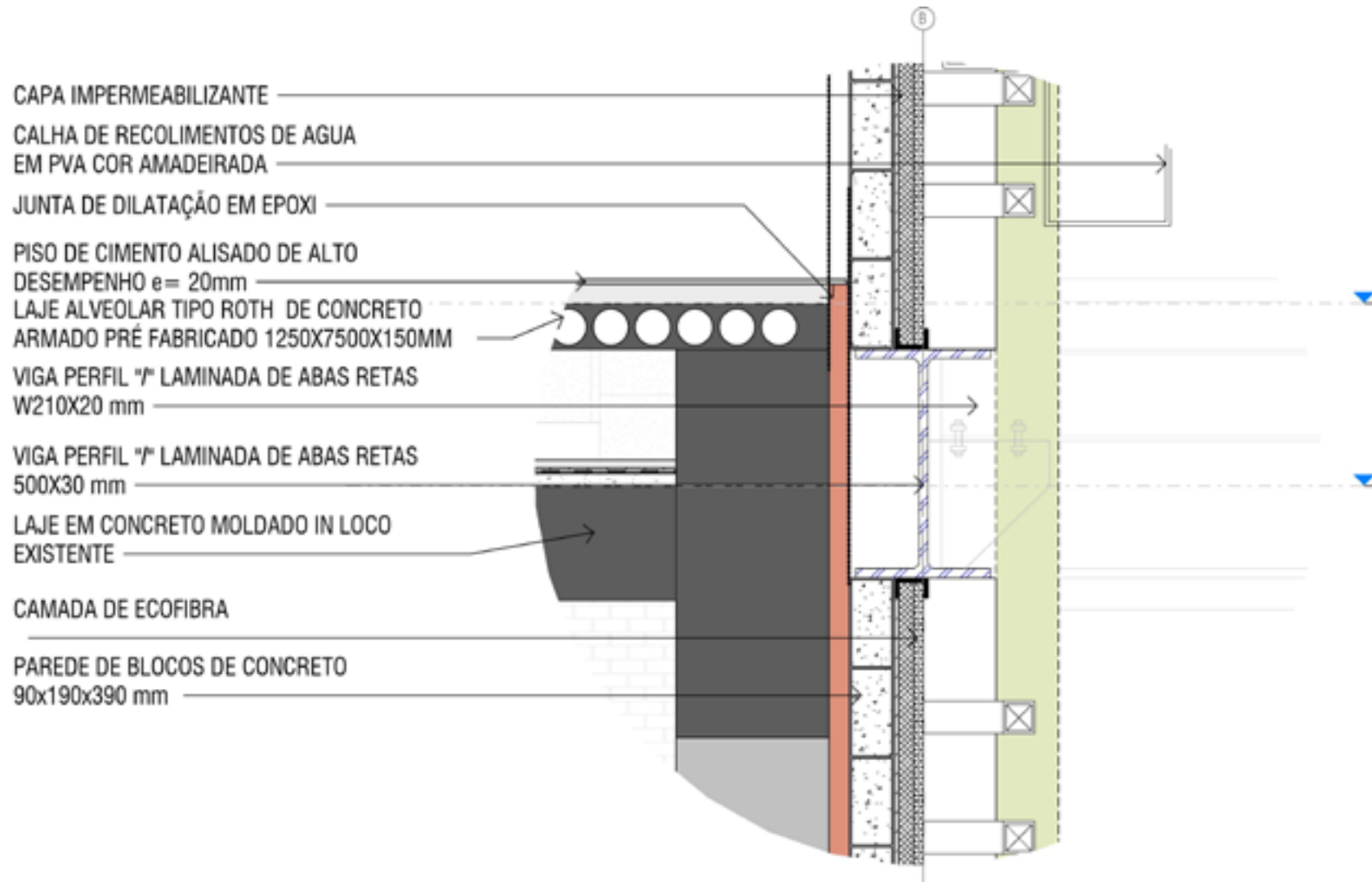

# DETALHAMENTOS FACHADA X COBERTURA

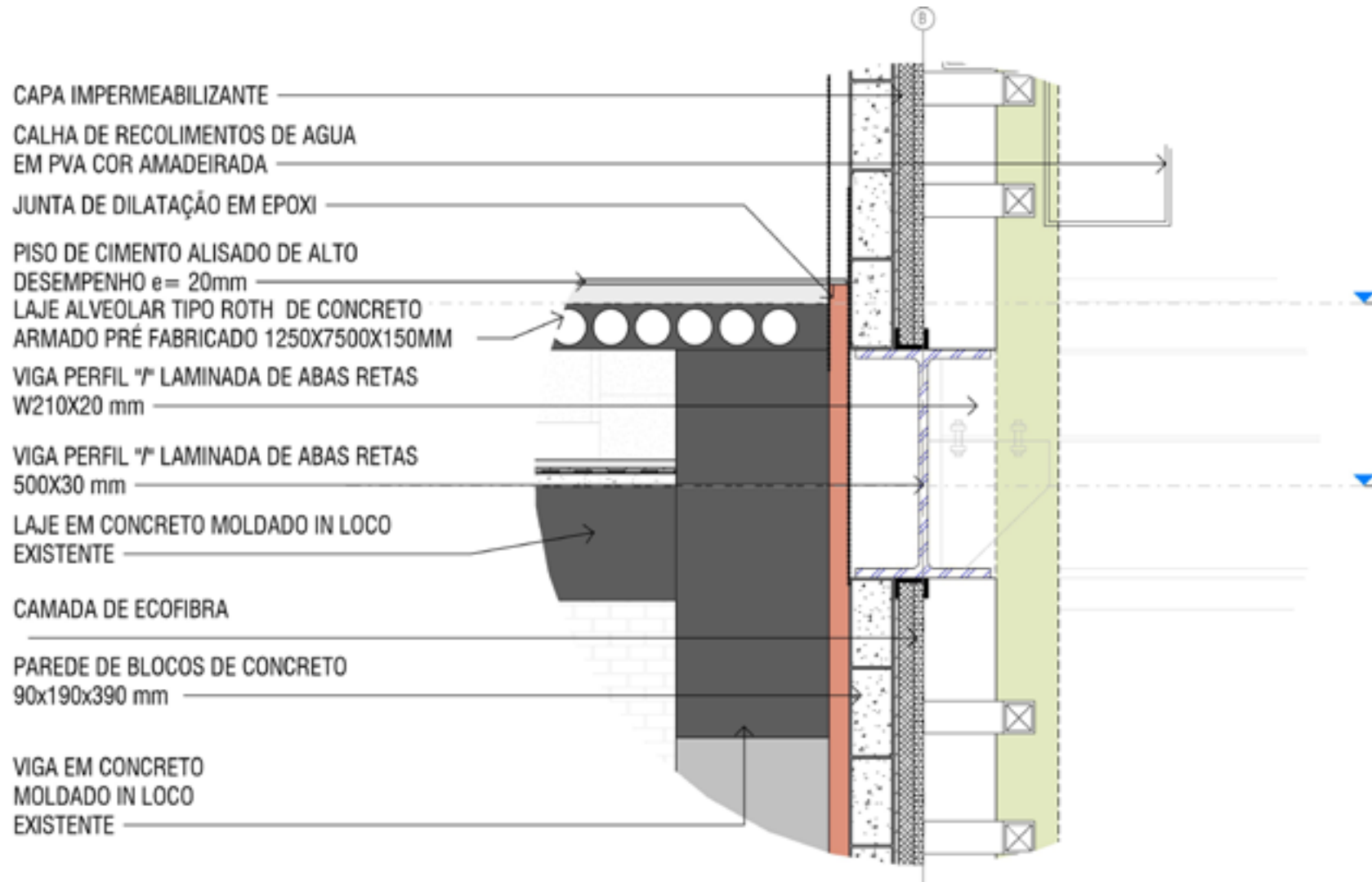

# DETALHAMENTOS FACHADA X COBERTURA

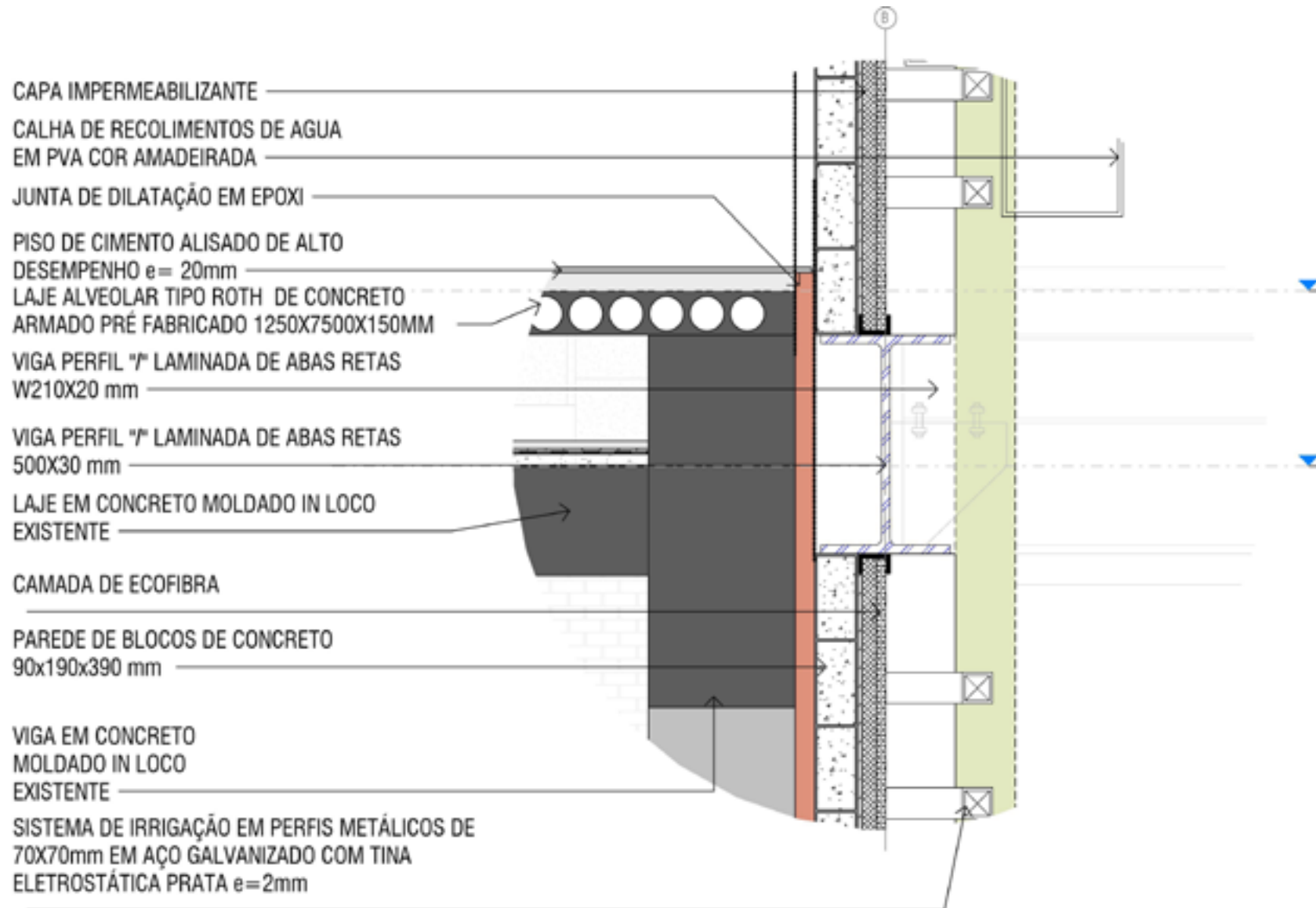

# DETALHAMENTOS FACHADA X COBERTURA

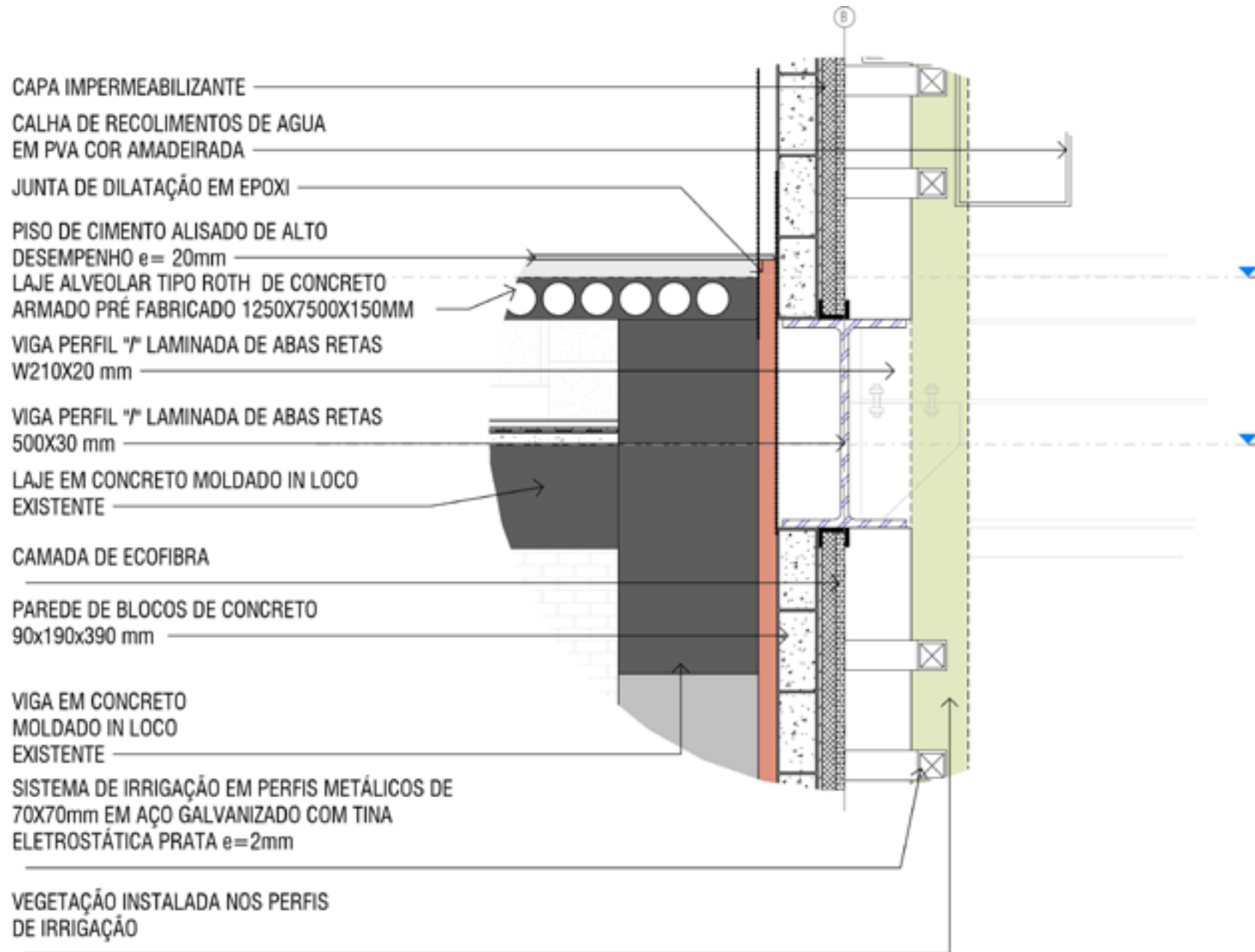

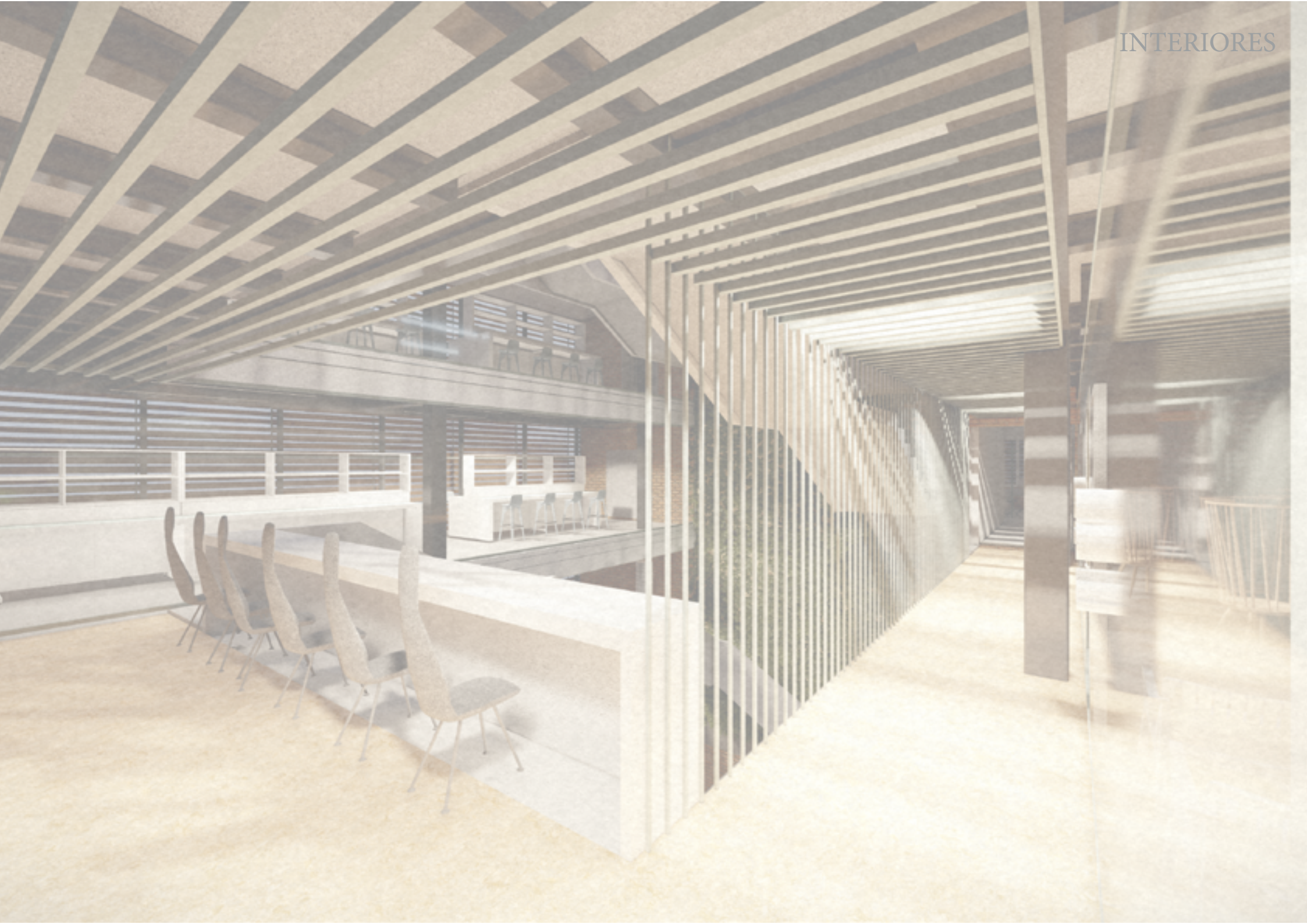





PREPARAÇÃO

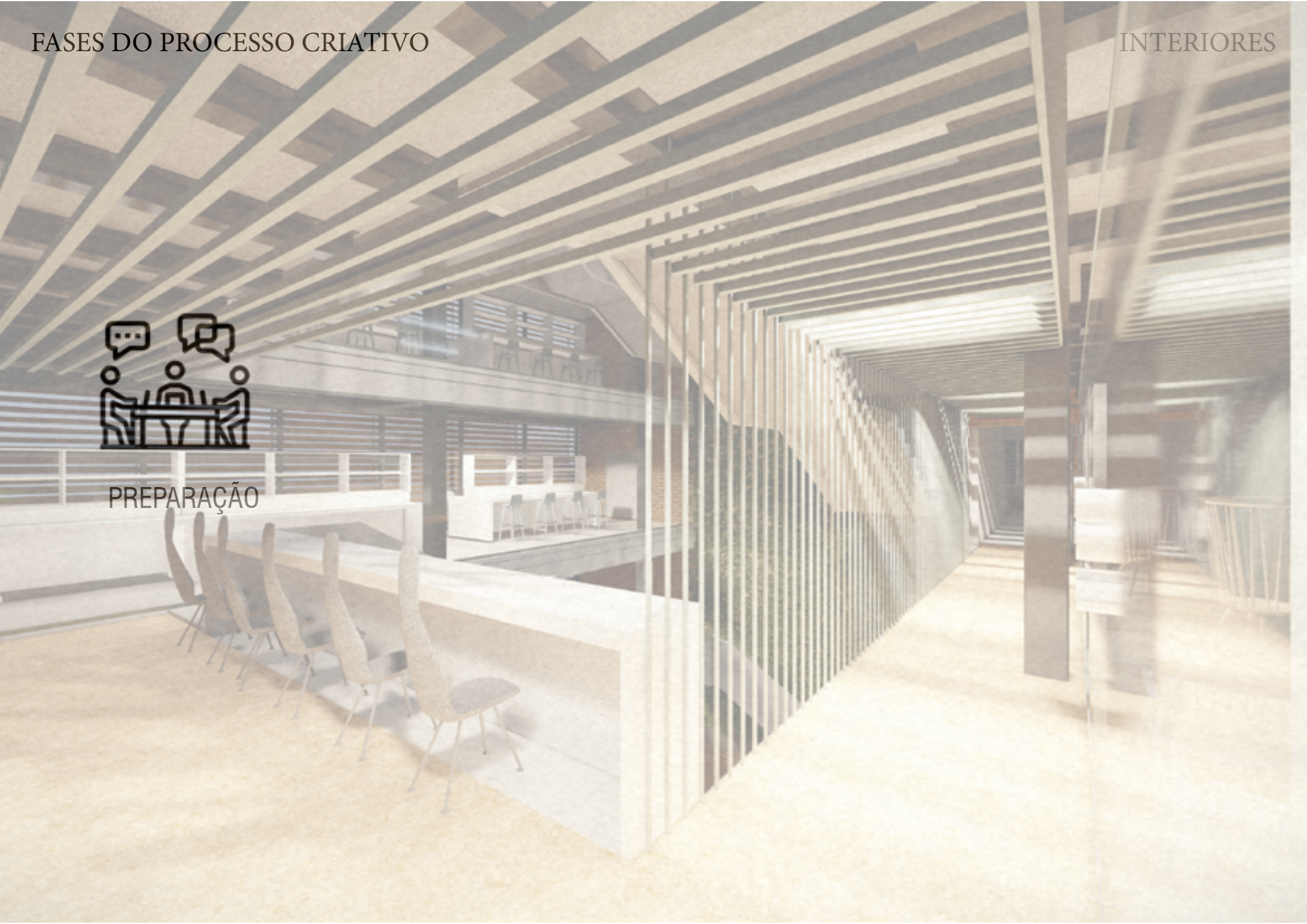



PREPARAÇÃO



INCUBAÇÃO

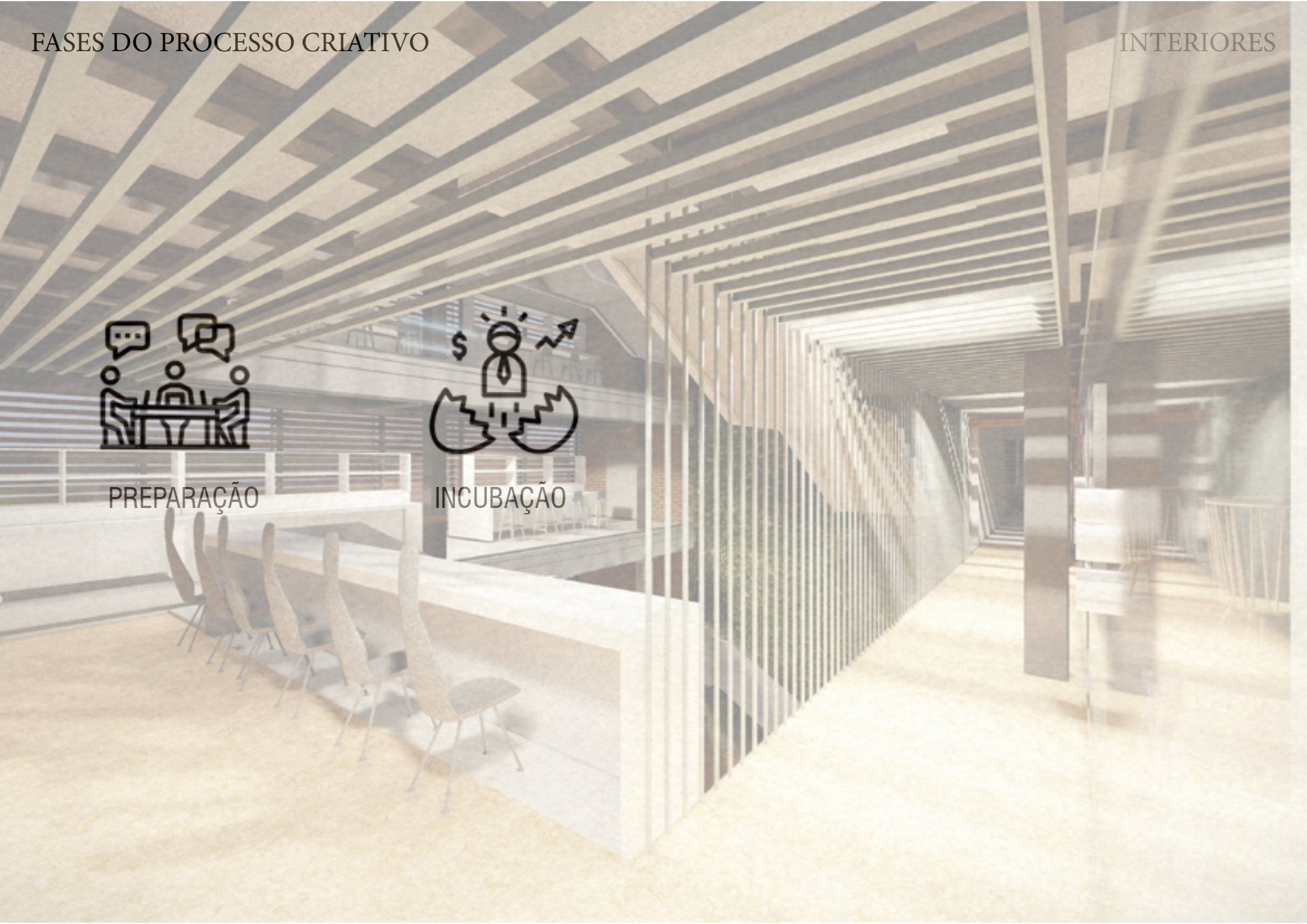



PREPARAÇÃO



INCUBAÇÃO



ILUMINAÇÃO



PREPARAÇÃO



INCUBAÇÃO



ILUMINAÇÃO



VERIFICAÇÃO

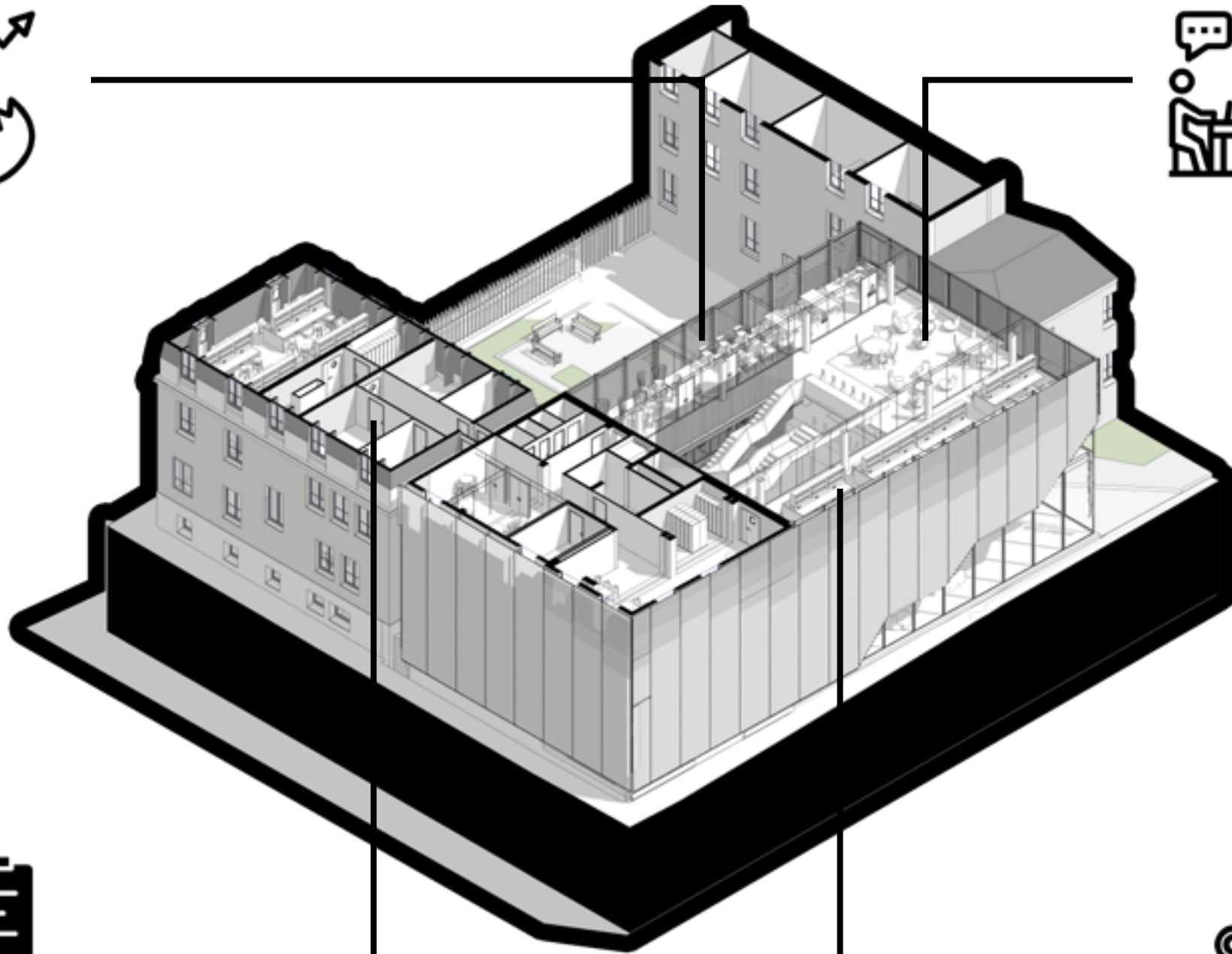













ENTRADA  
PRINCIPAL





Tendo em vista, o momento político em que vivemos, torna-se imprescindível mostrar com exemplos de outros países, que investir em ciência, e manter e expandir as descobertas feitas em um país não é apenas respeitar a história desse país, mas também a chave principal para que um ele continue desenvolvendo seu potencial científico, cultural e econômico. Além disso, o objetivo desse projeto, também é colocar em evidência uma das maiores representantes femininas da ciência e mostrar a importância da luta pela igualdade de sexos no meio acadêmico e no meio profissional.

"Nada na vida deve ser temido,  
apenas deve ser entendido.  
Agora é a hora de entender mais, para que possamos  
ter menos medo."  
(Marie Curie)



**MUITO OBRIGADA!**