

Artigo Original

Recebido em 22/11/2006, aceito em 23/04/2007

**Analog reconfigurable
technologies for EMG signal
processing**

Tecnologias analógicas reconfiguráveis para processamento de sinal eletromiográfico

Paulo Roberto Stefani Sanches*
André Frotta Müller

Hospital de Clínicas de Porto Alegre
Serviço de Engenharia Biomédica – Centro de Pesquisas
90035-903, Porto Alegre, RS
E-mail: psanches@hcupa.ufrgs.br

Luigi Carro
Altamiro Amadeu Susin

Programa de Pós-Graduação
em Engenharia Elétrica/UFRGS

Percy Nohama

Programa de Pós-Graduação em Engenharia
Elétrica e Informática Industrial/UTFPR
Programa de Pós-Graduação Multidisciplinar
em Tecnologia em Saúde/PUC-PR

*Autor para correspondência

Abstract

The acquisition and processing of electromyographic (EMG) signals are important steps for clinical applications involving the diagnosis of diseases, and also for the control of myoelectric prostheses or functional electrical stimulation systems. EMG signals are usually processed using analog circuits such as instrumentation amplifiers, filters, RMS converters or rectified average value converters. The design of such traditional circuits, however, especially during the validation phase, is time-consuming. This paper describes the development of an innovative biomedical application using commercially available Field Programmable Analog Arrays (FPAAs). All the functions required for the utilization of EMG signals were implemented using the resources of a single FPAA. The circuit can be configured at any time, either through a new download or through on-the-fly updates to an already functioning configuration. FPAA circuit model AN221E04 enabled the acquisition of low amplitude biopotentials (10 μ V to 500 μ V) with high common mode interference. The programmable circuit proved to be flexible, since it was possible to modify analog circuit characteristics such as filter cut-off frequencies, gains and reference voltages by software and during circuit operation. The high consumption of the circuit is the main limiting factor, once batteries supply are needed for galvanic isolation.

Keywords: Field Programmable Analog Arrays, Biopotentials acquisition, System-on-chip.

Resumo

A aquisição e o processamento de sinais eletromiográficos é importante em aplicações clínicas envolvendo o diagnóstico de doenças, bem como no controle de próteses mioelétricas ou sistemas de estimulação elétrica funcional. Tradicionalmente os sinais eletromiográficos são processados usando-se circuitos analógicos, como amplificadores de instrumentação, filtros, conversores RMS ou de valor retificado médio. O projeto destes circuitos clássicos, embora bastante conhecidos, demanda tempo principalmente na fase de validação e testes. Neste artigo é mostrado o desenvolvimento de um circuito capaz de desempenhar essas funções empregando arranjos analógicos programáveis (Field Programmable Analog Arrays – FPAA). As funções mencionadas acima foram implementadas usando os recursos de um único arranjo analógico programável. A programação dos circuitos pode ser realizada a qualquer momento, através do “download” de uma nova configuração ou atualização da configuração atual durante a operação do sistema. O circuito com FPAA modelo AN221E04 do fabricante Anadigm mostrou excelente desempenho na captação de biopotenciais de amplitude baixa, da ordem de 10 μ V a 500 μ V e com interferências de modo comum significativamente superiores. O circuito mostrou-se versátil com a possibilidade de modificar as características dos circuitos analógicos, como frequências de corte de filtros, ganhos e tensões de referência por software e “on the fly”, ou seja, durante a operação do equipamento. O consumo elevado do circuito é o principal fator limitante, pois como se deseja isolamento galvânica, o uso de baterias é o ideal.

Palavras-chave: Arranjos analógicos programáveis, Aquisição de biopotenciais, Sistemas em um único chip.

Introduction

Electromyographic (EMG) signals have been used in on-off or proportional prosthesis control, as well as in systems of functional electrical stimulation control (Graupe and Kordylewski, 1997; Hudgins *et al.*, 1994; Okuno *et al.*, 1996; Quevedo and Cliquet Jr., 1993; Thorsen *et al.*, 2001). The EMG signal has a limited frequency range, with a large portion of its spectral power in the 50 to 350 Hz bandwidth.

Using the EMG signal for control purposes requires that it must be transformed into a well-defined signal. Such transformation is achieved with the use of special amplification configurations, analog filtering and digital signal processing. Several methods have been suggested to obtain useful information from the EMG signal, including classification, auto-regressive models, spectral coefficients and neural networks. Nevertheless, the most used methods are the average rectified value (ARV) and root mean square (RMS) of the acquired signal over a sliding time window. It is interesting to note that the average rectified signal is more easily obtained, but the RMS is better correlated with the energy contained in the signal (Clancy *et al.*, 2001; Thorsen *et al.*, 2001).

The first step in the processing of EMG signals is usually done with analog circuits, using integrated instrumentation amplifiers with high Common-Mode Rejection Ratio (CMRR) to minimize the effect of common mode interference (Burke and Gleeson, 2000). The filtering stages are also implemented using analog circuits, usually with low-pass and high-pass filters of second or even fourth order, when additional attenuation is required for frequencies outside the bandwidth. The amplitude of acquired EMG signals ranges from 10 μ V to 1 mV. These signals need amplification from 60 to 100 dB, so that 1 V signals can be obtained at the output of the amplification sub-system.

During the process of biopotential acquisition, it is usually necessary to adjust amplification levels and tune bandwidth, because the signal amplitude varies among subjects, as well as the frequency spectra among different kinds of biopotentials, different muscle groups and skin-electrode coupling. For that, an RMS-to-DC converter can be implemented using analog components or digitalizing the amplified EMG signal and processing the RMS value in a microprocessor. One possible choice to achieve this type of adjustment is the use of Field Programmable Analog Arrays (FPAAs). FPAAs offer the possibility of having all the required analog circuits in a single programmable component. This solution ensures

greater system flexibility and reliability, a reduction of circuit dimensions and costs.

The present article describes the design and implementation of a circuit using the Anadigm® FPAA for the acquisition and analog processing of EMG signals. The purpose of this architecture is to provide an EMG signal with adequate characteristics for control of external devices such as prostheses or electrical stimulators.

FPAA characteristics

Just as Field Programmable Gate Arrays (FPGA) have revolutionized digital circuit design, FPAAs have introduced easy prototyping and reduced design times to analog circuit design. The most important element in FPAA is the Configurable Analogue Block (CAB), which manipulates signals and the interconnecting routing network. An FPAA is an integrated circuit that can be programmed and reprogrammed to perform an open-ended set of analog circuit functions. The circuit configuration files are downloaded into the FPAA from a PC or system controller or from an attached EEPROM, producing a fully functional analog circuit. The circuit configuration is completely changeable at any time, either as a new download or with on-the-fly updates to an already functioning configuration.

The Anadigm® AN221E04 FPAA, which employs switched capacitor technology, has several CABs with configurable characteristics and can be programmed to undertake various functions, such as that of filter, amplifier, multiplier, comparator and others (AN220E04, 2003). These functions can be used for acquisition and processing of biological signals.

The FPAA chopper amplifier has a CMRR of 102 dB and minimizes common mode interference signals as well as 60 Hz power-line interference.

Circuit Description

Circuit implementation was carried out with the AnadigmDesigner®2 software, which includes a circuit simulator and a programming device, through a serial interface on the AN220D04 evaluation board for operational tests (Anadigm, 2004).

The battery-powered evaluation board was connected to a computer using an optical interface for patient safety.

The block diagram of the proposed system is shown in Figure 1.

Acquisition of the EMG signal

The amplitude of EMG signals acquired by the surface

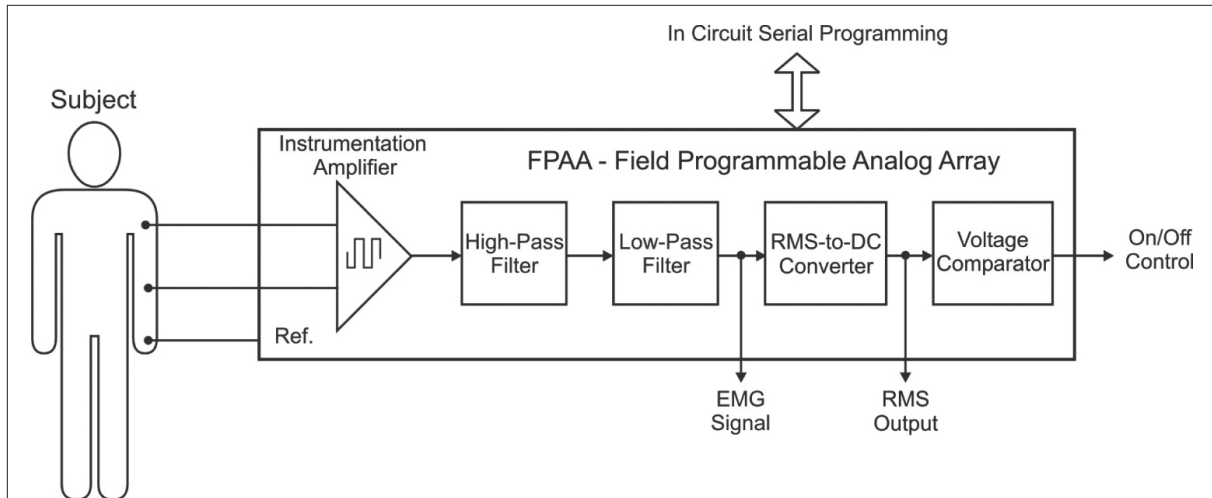

Figure 1. Block diagram of the proposed system for EMG signal acquisition and processing.

electrodes ranged from 10 μV up to 1 mV. However, the common mode signal (interference) can reach as high as a few volts.

Several techniques are recommended to interface the FPAA to other analog circuits; however none of them was suitable for the acquisition of biopotentials (AN-205). Therefore, we proposed a new configuration, in which the reference electrode is connected to the FPAA reference pin (VMRC) and the active electrodes are directly connected to chopper inputs.

Chopper amplifiers are used to amplify very small and very low frequency signals with DC components that must be preserved from alteration due to the amplifier offset. This is not the case with EMGs, whose spectrum has negligible power below 10 Hz, but it was the front end option offered by the FPAA that showed better results.

The minimization of interference sources was obtained with shielding techniques and by using shorter cables, preventing ground loops, with skin preparation at the electrode area and using self-adhesive Ag-AgCl electrodes. These procedures enable acquisition of a signal with adequate signal-to-noise ratio in order to continue signal processing in the analog domain.

Filtering

The bandwidth for the EMG signal was defined from 50 Hz to 350 Hz. As a design option we adopted the low order filter configuration that allows capturing an EMG signal with adequate signal-to-noise ratio. This was implemented with a second-order Chebyshev band-pass filter and a bilinear filter; therefore, the attenuation for low frequencies was 20 dB per decade and 40 dB per decade in frequencies above the bandwidth.

The input stage was implemented using a chopper amplifier configured with a 64 \times gain. The first filter stage was a band-pass with central frequency of 200 Hz, 5 \times gain and bandwidth of 300 Hz. The second filter stage was a low-pass with cut-off frequency of 500 Hz and gain of 20. The total gain of the signal conditioning circuit was 6,400 (76 dB). All parameters can be reconfigured at any time.

The transfer function of the acquisition circuit (amplification and filtering) appears in equations 1 and 2, which represent the transference functions of the chopper input stage, biquadratic band-pass filter and low-pass bilinear filter, respectively.

$$\frac{V_{out}(s)}{V_{in}(s)} = (G_{Chopper}) \cdot \left(\frac{2\pi f_{BP} \frac{G_{BP} \cdot s}{Q}}{s^2 + 2\pi \frac{f_{BP}}{Q} s + (2\pi f_{BP})^2} \right) \cdot \frac{2\pi f_{LP} G_{LP}}{s + 2\pi f_{LP}} \quad (1)$$

$$\frac{V_{out}(s)}{V_{in}(s)} = (64) \cdot \left(\frac{2\pi \cdot 200 \cdot \frac{5}{0.67} s}{s^2 + 2\pi \frac{200}{0.67} s + (2\pi \cdot 200)^2} \right) \cdot \frac{2\pi \cdot 500 \cdot 20}{s + 2\pi \cdot 500} \quad (2)$$

where: $G_{Chopper}$: Chopper amplifier gain; G_{BP} : Band-pass filter gain; G_{LP} : Low-pass filter gain; f_{BP} : Band-pass filter center frequency; f_{LP} : Low-pass filter cut-off frequency; Q : Band-pass quality factor.

Figure 2 shows the frequency response of equation 1, the experimental plot of the input stage obtained using a signal generator (HP 33120A) and the simulation in AnadigmDesigner®2 software all plotted with Matlab®. The theoretical and experimental results were similar and the differences are due to the experimental errors or FPAA circuit tolerance. The simulations prove that the available FPAA development tools are reliable.

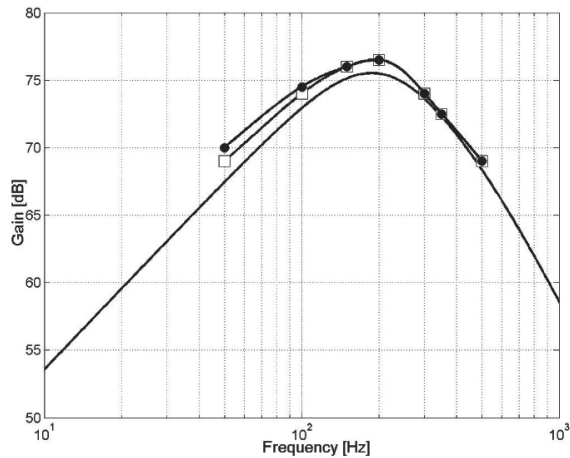

Figure 2. Frequency response plots: Matlab® simulations (solid line), AnadigmDesigner@2 simulation (□) and experimental (●).

Determination of RMS value

The determination of RMS was carried out with the classic topology shown in Figure 3. The blocks of multiplication and square root extraction were implemented with CABs in the FPAA. An external RC was used as a first-order filter directly connected to FPAA differential outputs and re-injected on the same FPAA, as can be seen in Figure 5.

The RC was experimentally adjusted, using the EMG signal acquired from a volunteer's biceps muscle, using self-adhesive Ag-AgCl electrodes, in order to obtain a RMS signal with low ripple, however assuring the response time of the circuit (Figure 4). The final values were $R = 220 \text{ k}\Omega$ and $C = 470 \text{ nF}$, defining a cut-off frequency of 1.5 Hz.

The last stage of analog signal processing consists of a comparator circuit that generates a trigger pulse or on/off control for external devices when the EMG RMS level exceeds an adjusted set point threshold. The FPAA circuit has a variable reference comparator that executes this function and the reference voltage acts as a sensitivity threshold.

The complete circuit is shown in Figure 5. Outputs 3 and 4 on the right upper corner of Figure 5 correspond to the square of amplified and filtered EMG signals, while outputs 7 and 8 (right bottom corner) correspond to the EMG signal's RMS after analog signal processing.

Conclusions

CMRR of FPAA circuit model AN221E04 enabled the

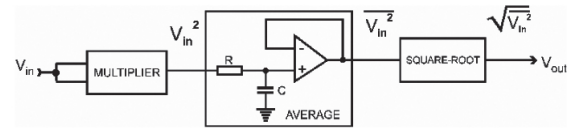

Figure 3. Classic topology for generation of RMS value using analog circuits.

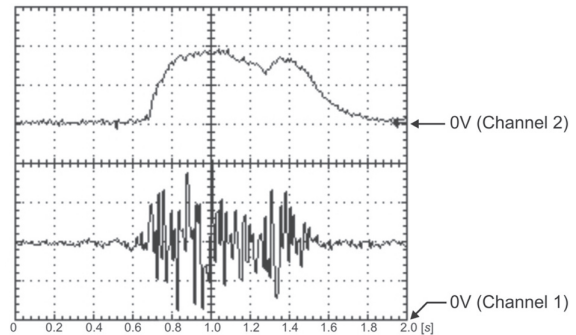

Figure 4. RMS value (Channel 2: 500 mV/div) and Biceps muscle signal (Channel 1: 1 V/div).

acquisition of low amplitude biopotentials ($10 \mu\text{V}$ to $500 \mu\text{V}$) with high common mode interference. In turn, the use of interference minimization techniques produced a clean signal, with adequate quality to be used as control signal for myoelectric prostheses or electrical stimulators.

The programmable circuit proved to be flexible, since it was possible to modify analog circuit characteristics such as filter cut-off frequencies, gains and reference voltages by software and during circuit operation. As this work proved, FPAAs facilitate rapid and reliable prototyping of analog systems. However, there is a limitation in the range of filter cut-off frequencies, and it is not possible to configure filters with a cut-off frequency ratio ($f_{\text{max}}/f_{\text{min}}$) superior to 50 times for second-order filters (biquadratic) and 100 times for bilinear filters (first order) in the same FPAA loop.

The acquisition of different biopotentials in the same patient, as for example the simultaneous acquisition of the ECG and EMG signals, with some limitations in signal bandwidth, could be carried with the resources of a single FPAA.

The high consumption of the circuit is the main limiting factor. The use of batteries is the best choice when galvanic isolation is desired. However, as the circuit has a global consumption of approximately 700 mW, autonomy is severely compromised, and the use of large and high capacity batteries becomes

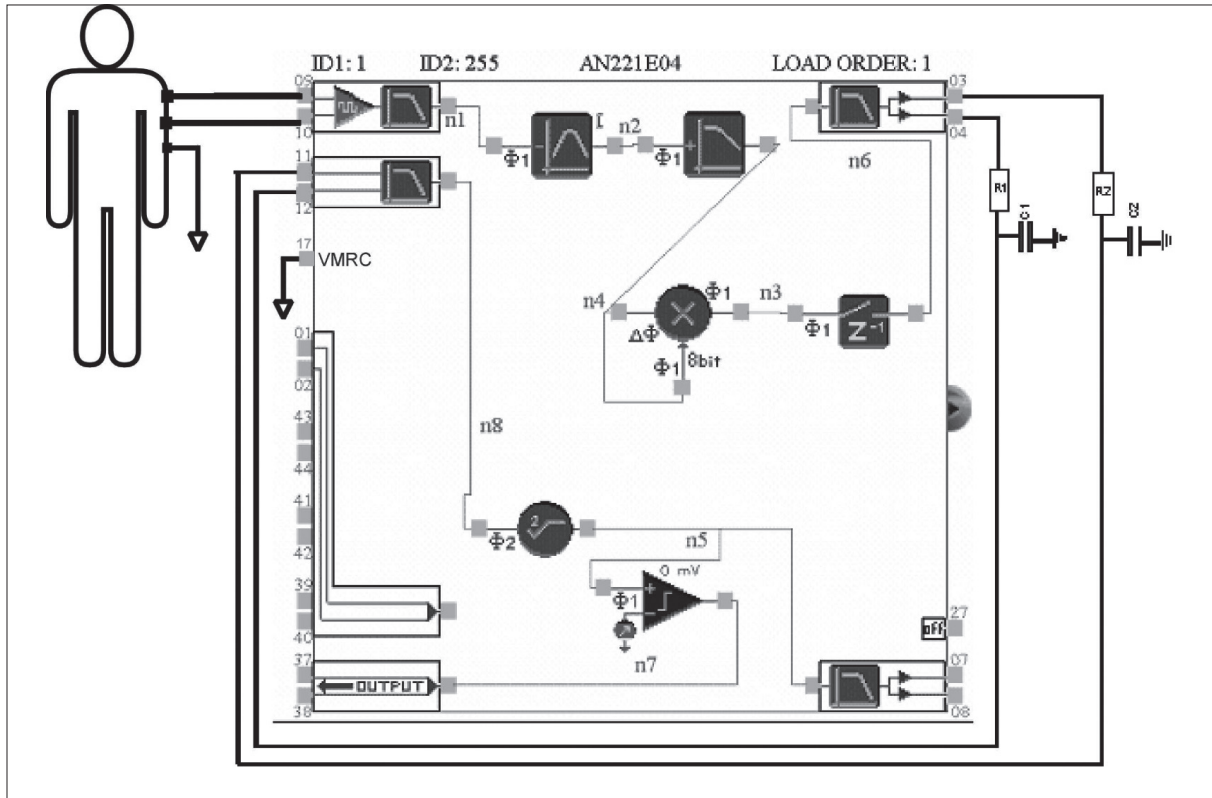

Figure 5. Complete FPAACircuit for acquisition of EMG signal.

necessary, preventing miniaturization of the circuit. The development of low power FPAAs is important for biomedical applications, which require a narrow signal bandwidth, typically lower than 10 kHz. For these applications the miniaturization and customization of analog circuits would be beneficial, especially for implanted devices.

References

- AN-205 (2003), "Interfacing Analog Signals to the Anadigmvortex FPAACDevices – Application Notes", In: http://www.anadigm.com/_doc/AP021000-U205.pdf, accessed: 10/03/2006.
- AN220E04 Datasheet (2003), "Dynamically Reconfigurable FPAAC", In: http://www.anadigm.com/_doc/DS020700-U001.pdf, accessed: 10/03/2006.
- Anadigm Designer® 2 (2004), "User Manual", In: http://www.anadigm.com/_doc/UM020800-U001.pdf, accessed: 10/03/2006.
- Burke, M.J., Gleason, D.T. (2000), "A micropower dry-electrode ECG preamplifier", *IEEE Transactions on Biomedical Engineering*, v. 47, n. 2, p. 155-162.
- Clancy, E.A., Bouchard, S., Rancourt, D. (2001), "Estimation and application of EMG amplitude during dynamic contractions", *IEEE Engineering in Medicine and Biology Magazine*, v. 20, n. 6, p. 47-54.
- Graupe, D., Kordylewski, H. (1997), "Neural network control of neuromuscular stimulation in paraplegics for independent ambulation", In: *Proceedings of the 19th IEEE/EMBS Annual International Conference*, Chicago, v. 3, p. 1088-1091, 30 Oct-02 Nov.
- Hudgins, B., Parker, P., Scott, R.N. (1994), "Control of artificial limbs using myoelectric pattern recognition", *Medical & Life Sciences Engineering*, v. 13, p. 21-38.
- Okuno, R., Yoshida, M., Akazawa, K. (1996), "Development of biomimetic prosthetic hand controlled by electromyogram", In: *Proceedings of 4th International Workshop on Advanced Motion Control*, Mie, v. 1, p. 103-108, 18-21 Mar.
- Quevedo, A.A.F., Cliquet Jr., A. (1993), "A system for digital analysis of electromyographic signals", In: *Proceedings of the Myoelectric Control Symposium'93 [Future Trends in myoelectric technology]*, Fredericton, p. 128-132, 25 Feb.
- Thorsen, R., Spadone, R., Ferrarin, M. (2001), "A pilot study of myoelectrically controlled FES of upper extremity", *IEEE Transactions on Neural Systems and Rehabilitation Engineering*, v. 9, n. 2, p. 161-168.

